



Technical Information

.....
Specifications for Power Macintosh 7200 series computers

Technical Information

Main unit

Processor

A PowerPC™ 601 processor with the following features:

- 75 megahertz (MHz) or 90 MHz
- 37.5 MHz system bus for 75 MHz systems; 45 MHz system bus for 90 Mhz systems
- built-in floating point unit (FPU)

Memory

- 8 or 16 megabytes (MB) RAM, supplied in removable DIMMs, expandable to a maximum of 256 MB
- 1 MB of video RAM (VRAM) on the main logic board, supplied in removable DIMMs, expandable to a maximum of 4 MB
- 4 MB of read-only memory (ROM)
- 8 kilobytes (K) of nonvolatile parameter memory
- 512 or 256K of static RAM supplied in a removable DIMM, used as a Level 2 cache for the PowerPC microprocessor (optional)



DRAM, VRAM, and cache configurations

You can have memory—dynamic random-access memory (DRAM) or video random-access memory (VRAM)—added to your computer in packages called Dual Inline Memory Modules, or DIMMs. You can also upgrade your computer's cache by installing a DIMM.

DRAM configurations

Your computer can use any DRAM configuration with DIMMs of these sizes: 8, 16, 32, or 64 MB.

You can increase your computer's DRAM to up to 256 MB. The main logic board has four slots (each with a 64-bit data bus) where DIMMs can be installed. To increase DRAM to the maximum of 256 MB, have an Apple-authorized dealer or service provider fill all four slots with 64 MB DIMMs. You can also fill slots with 8, 16, or 32 MB DIMMs.

Note: 128 MB DIMMs are available and can fit in the computer's memory slots to increase DRAM to as much as 512 MB. These DIMMs have not been tested for use with Power Macintosh 7200 and 7300 computers, however.

IMPORTANT The DIMMs should be 64-bit-wide, 168-pin fast-paged mode, with 70-nanosecond (ns) RAM access time or faster. The Single Inline Memory Modules (SIMMs) from older Macintosh computers are not compatible with your computer and cannot be used.

If you decide to have additional DRAM installed in your computer, the DIMMs can be installed one at a time in any order in any of the memory slots.

VRAM configurations

Your computer has additional VRAM. VRAM, like standard DRAM, is also provided in DIMMs. Your computer comes with 1 MB of VRAM on the main logic board. You can increase VRAM to 2 MB by installing one 1 MB DIMM in the first VRAM slot, or to 4 MB by filling all three VRAM slots with 1 MB DIMMs.

IMPORTANT The VRAM DIMMs must be 112-pin fast-paged mode, with 70 ns RAM access time or faster. Do not use 256K VRAM SIMMs.

Cache configurations

Your computer can support a cache up to a maximum of 1 MB. Cache DIMMs are available in various sizes from 256K to 1 MB.

Adding DRAM or VRAM, or upgrading the cache

WARNING Although instructions for installing DIMMs are provided in this manual, Apple Computer recommends that you have an Apple-certified technician install additional DRAM, VRAM, or cache. Consult the service and support information that came with your computer for instructions on how to contact an Apple-authorized service provider or Apple for service. If you install additional DIMMs yourself, you risk damaging your equipment, and this damage would not be covered by the limited warranty on your computer. See an Apple-authorized dealer or service provider for additional information about this or any other warranty question.

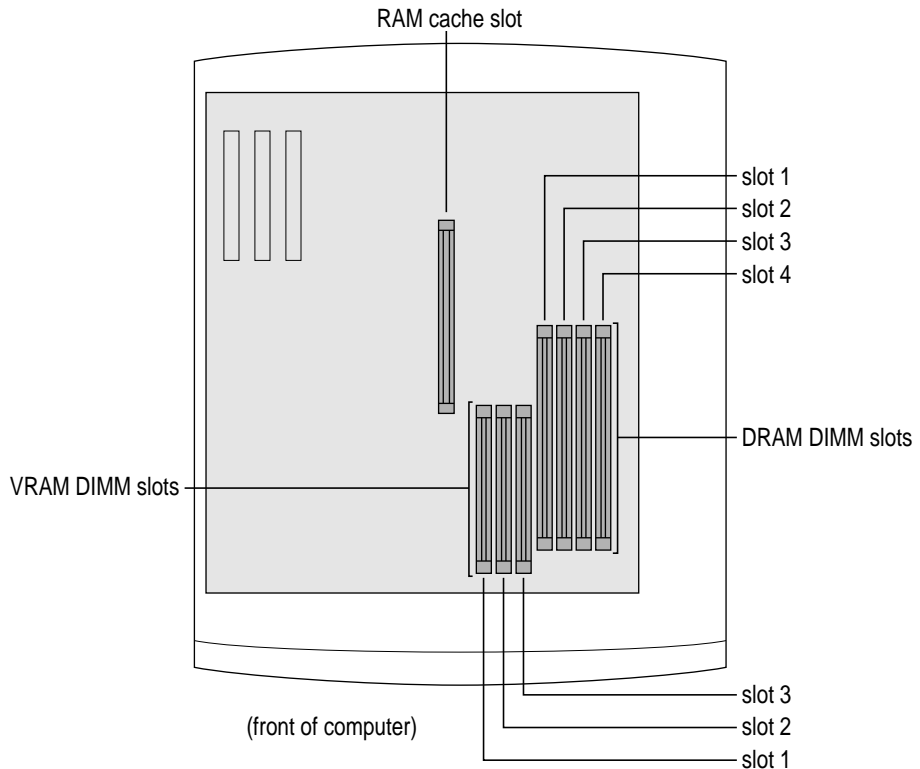

DRAM, VRAM, and cache DIMMs are installed as follows:

- 1 Make sure the voltage switch is set correctly for the voltage system you will be connecting the computer to.**

If you don't know the voltage used in the country you're in, refer to the table "Voltages for Different Locations" in the user's manual that came with your computer.

Check to see that the voltage switch on the back of your computer is properly set before you plug it in. If you need to change the setting, insert a small screwdriver here and slide the switch.

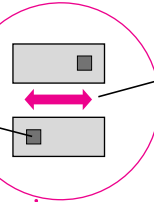

Set the switch to show "115" for voltages in the 100–130V range.
Set the switch to show "230" for voltages in the 220–270V range.

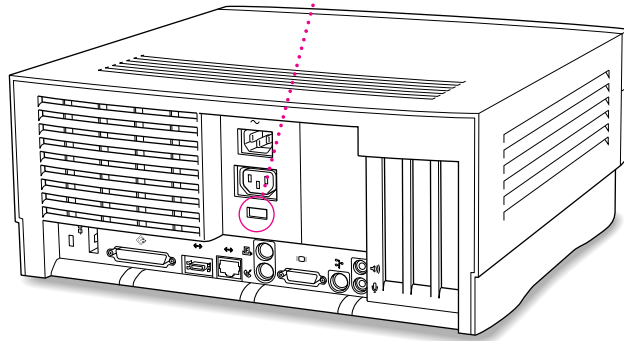

- 2 Plug the power cord into the back of the computer and into an AC outlet. Make sure the computer is turned off.**

- 3** Press the two release buttons under the front panel and slide the cover toward you approximately two inches.

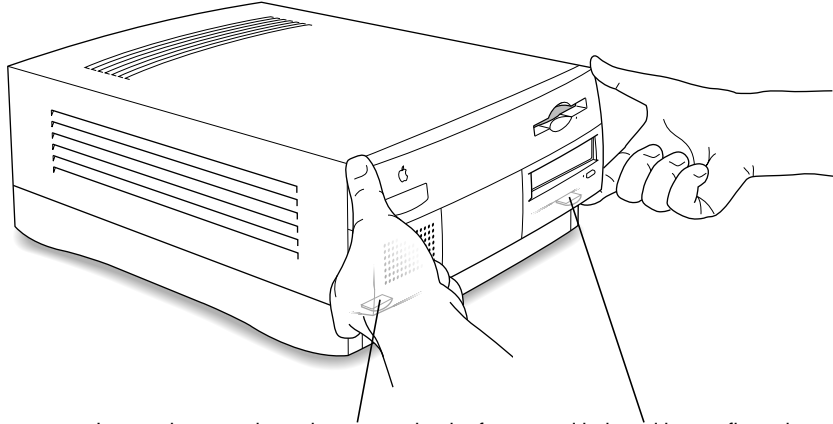

Locate the two release buttons under the front panel ledge with your fingertips.

While pressing the release buttons, pull the top cover forward approximately two inches to release it from the chassis.

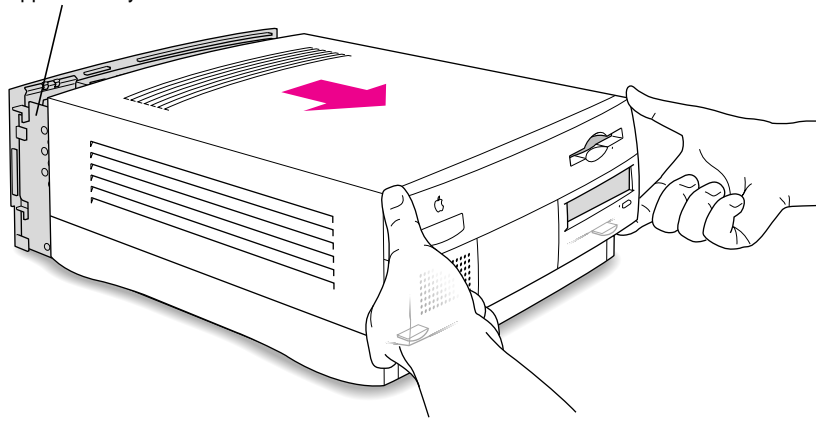

4 Remove the cover from the computer.

After you've slid the cover forward about two inches, lift it straight up and off the computer.

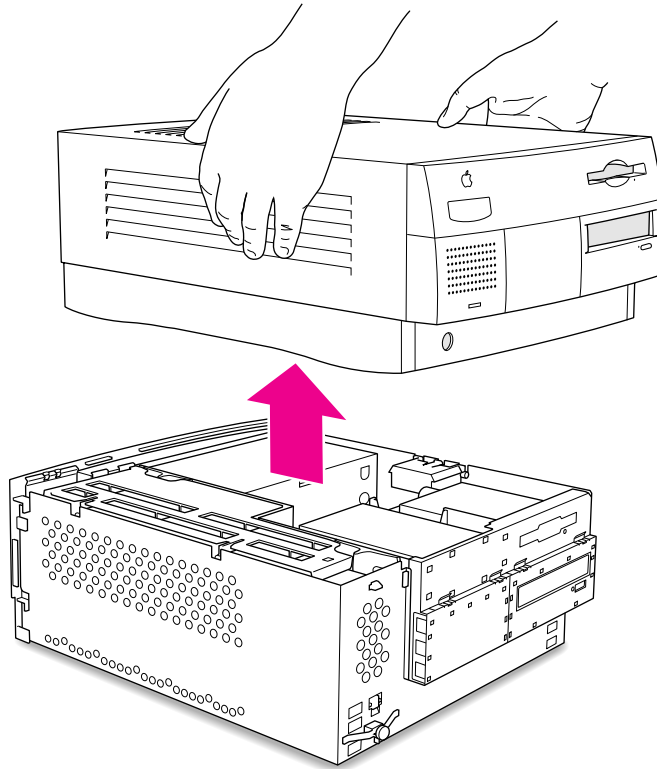

- 5 **Touch the metal part of the power supply case inside the computer to discharge static electricity.**

Always do this before you touch any parts, or install any components, inside the computer.

IMPORTANT Both DIMMs and the components inside your computer can be damaged by static electricity. Be sure to follow the procedure given here for discharging static electricity. To avoid damaging DIMMs, handle them only by the edges—never touch the connectors.

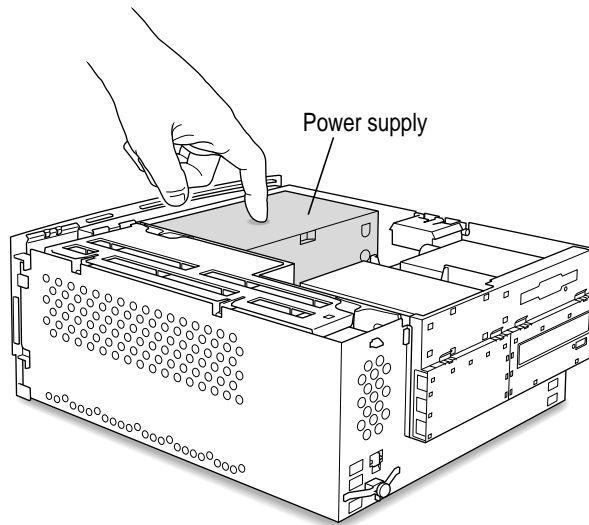

- 6 **Disconnect the power cord from the back of the computer.**

Remove the power cord from the back of the computer.

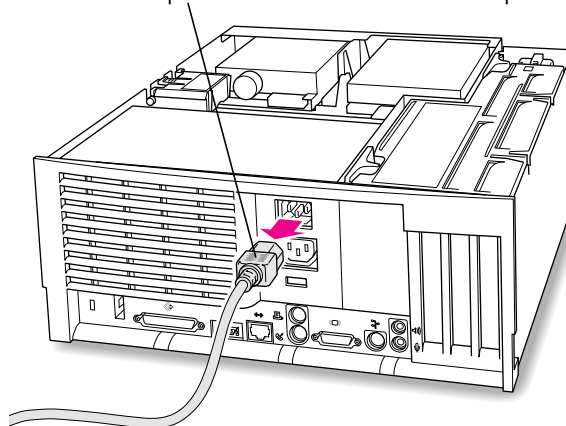

If you have a 75 MHz version of the Power Macintosh 7200: Your unit has no auxiliary fan. (Skip to step 9)

If you have a 90 MHz version of the Power Macintosh 7200: Your unit may have an auxiliary fan. Continue with step 7.

- 7** Check for the auxiliary fan by flipping the expansion card cover open. If you do have the fan, you need to remove it now as described here and in step 8. (If you don't have the fan, skip to step 9).

1 Flip the expansion card cover open.

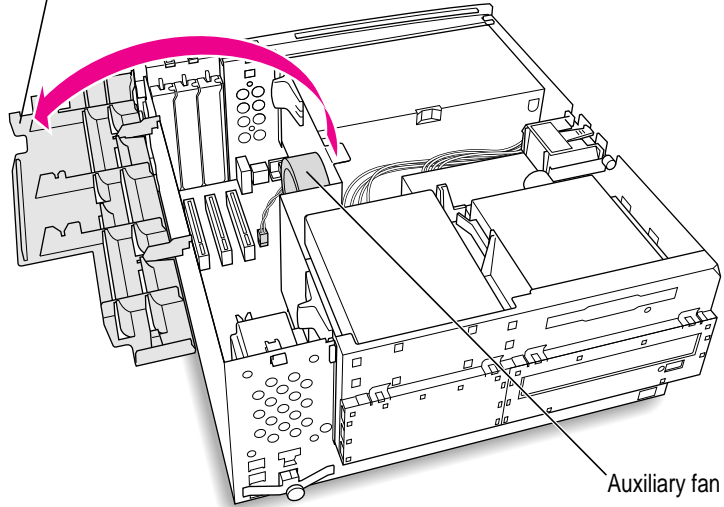

2 Check to see if your computer model has an auxiliary fan.

8 Disconnect the auxiliary fan from the main logic board, then close the expansion card cover.

1 Unplug the auxiliary fan cable from the main logic board.

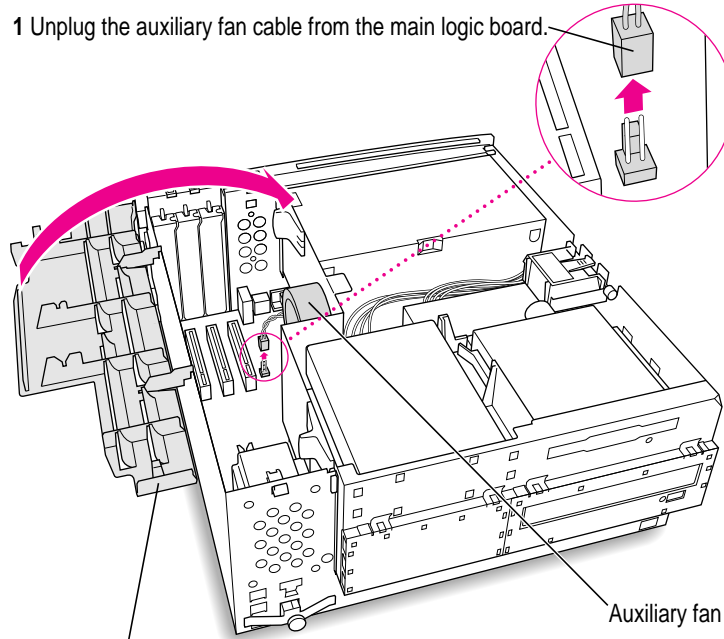

2 Flip the expansion card cover closed and snap it into place.
(Be sure to snap the cover back down on both ends.)

9 Flip out the support foot.

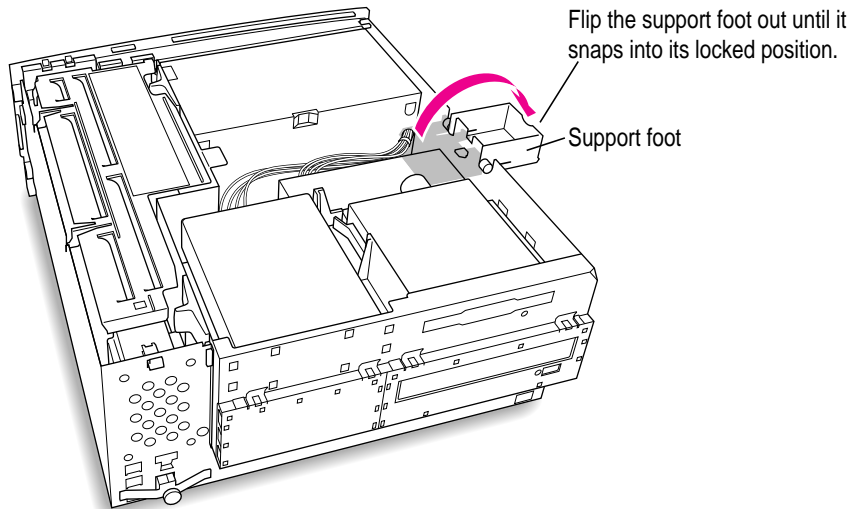

- 10** Unlock the top chassis by pressing the release switches toward the inside of the computer.

Move the release switches toward the inside of the computer to unlock the top chassis.

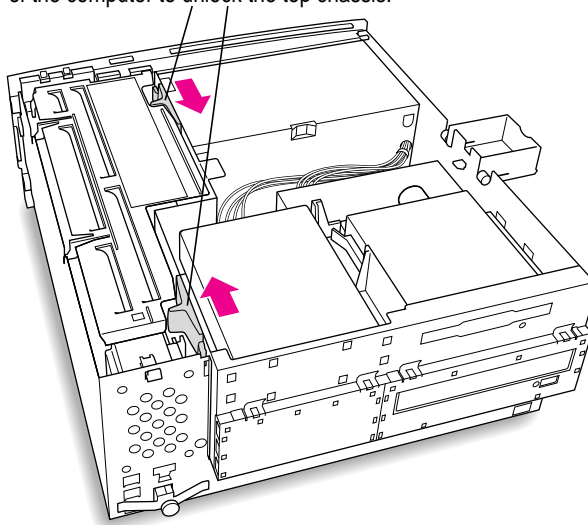

- 11** Using the tab shown below, lift the top chassis up to reveal the DRAM, VRAM, and cache slots.

You can use this tab to lift the top chassis.

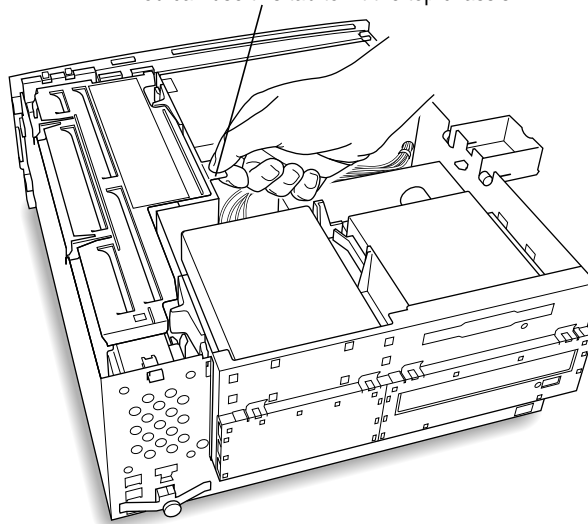

12 Swing the chassis up and insert the support arm in the hole as pictured below.

Gently swing the top part of the chassis up so that it rests on the support foot.

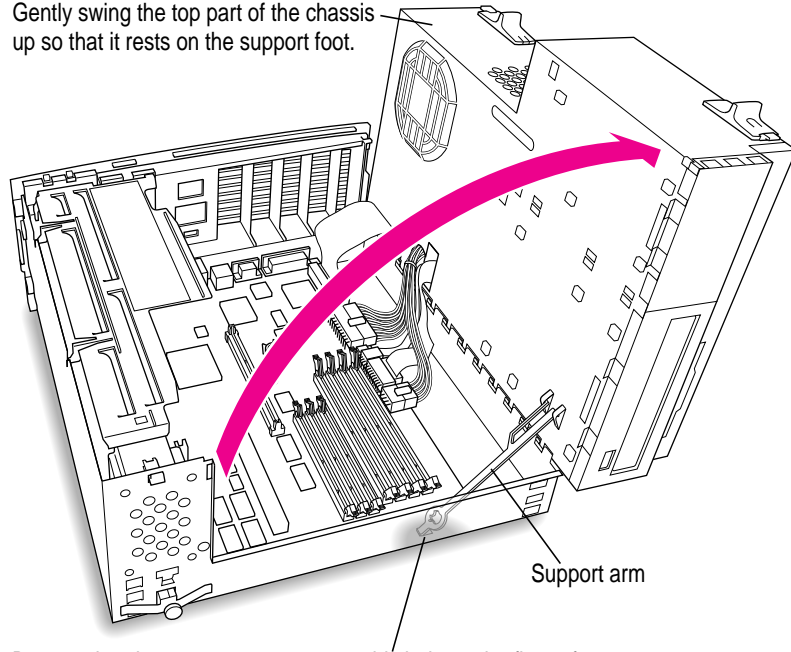

Be sure that the support arm engages this hole on the floor of the bottom chassis so that the top chassis is locked in place.



13 If you're installing DRAM DIMMs, align them in the DRAM sockets as pictured.

DRAM DIMM (Your DIMM's shape and components may vary.)

Connectors Notches DRAM socket (1 of 4)

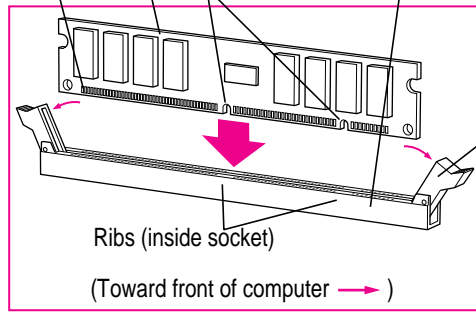

The DRAM DIMM is designed to fit into the socket only one way. Be sure to align the notches in the DIMM with the small ribs inside the socket. With the ejector(s) in the "open" position (as shown), push down on the DIMM until it snaps into place. The ejector(s) will automatically "close."

Ejector (Your socket may have one or two ejectors. They should be pushed outward and down to be in the "open" position, as shown.)

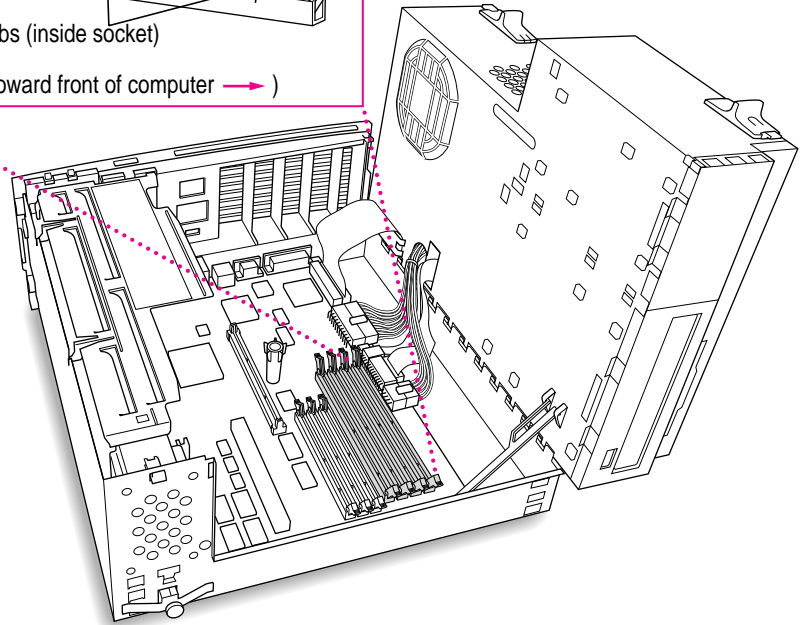

14 If you're installing VRAM DIMMs, place them in the VRAM sockets as illustrated below.

To upgrade VRAM to 2 MB, the DIMM should be placed in VRAM slot #1.
To upgrade to 4 MB, fill all VRAM slots with DIMMs.

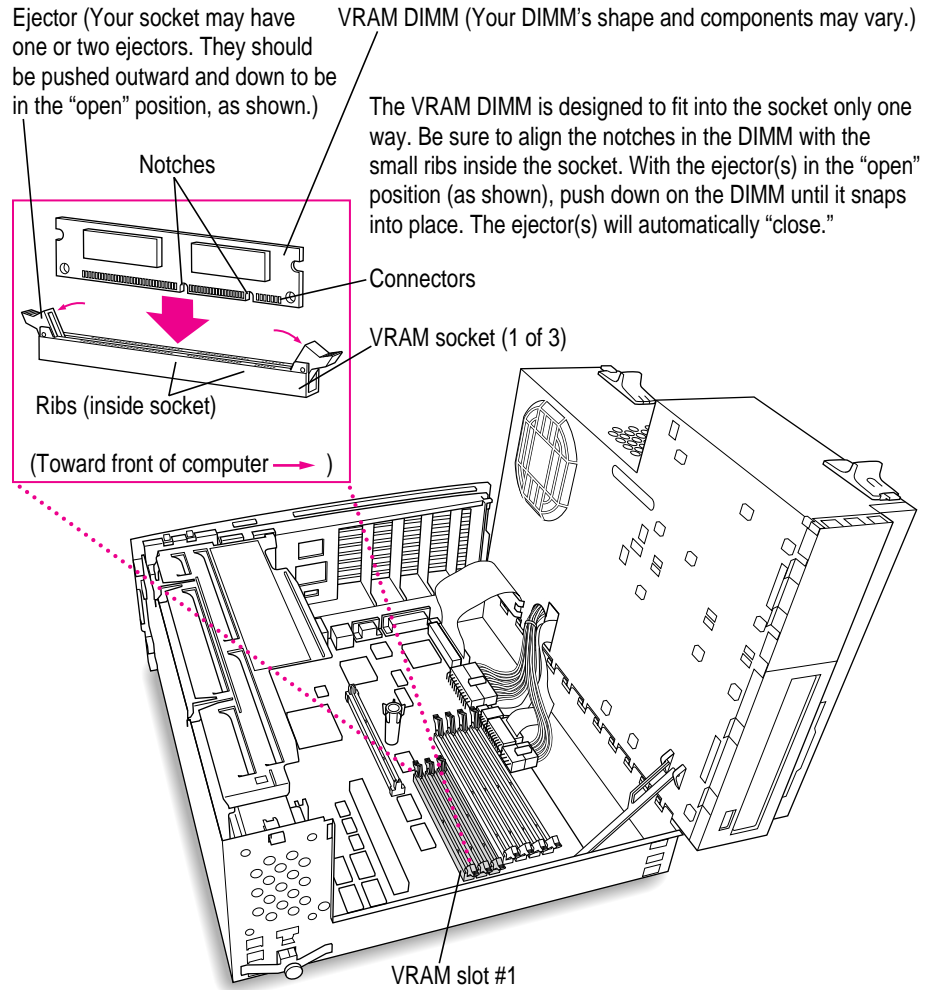

15 If you're installing a cache DIMM, insert the DIMM as illustrated below.

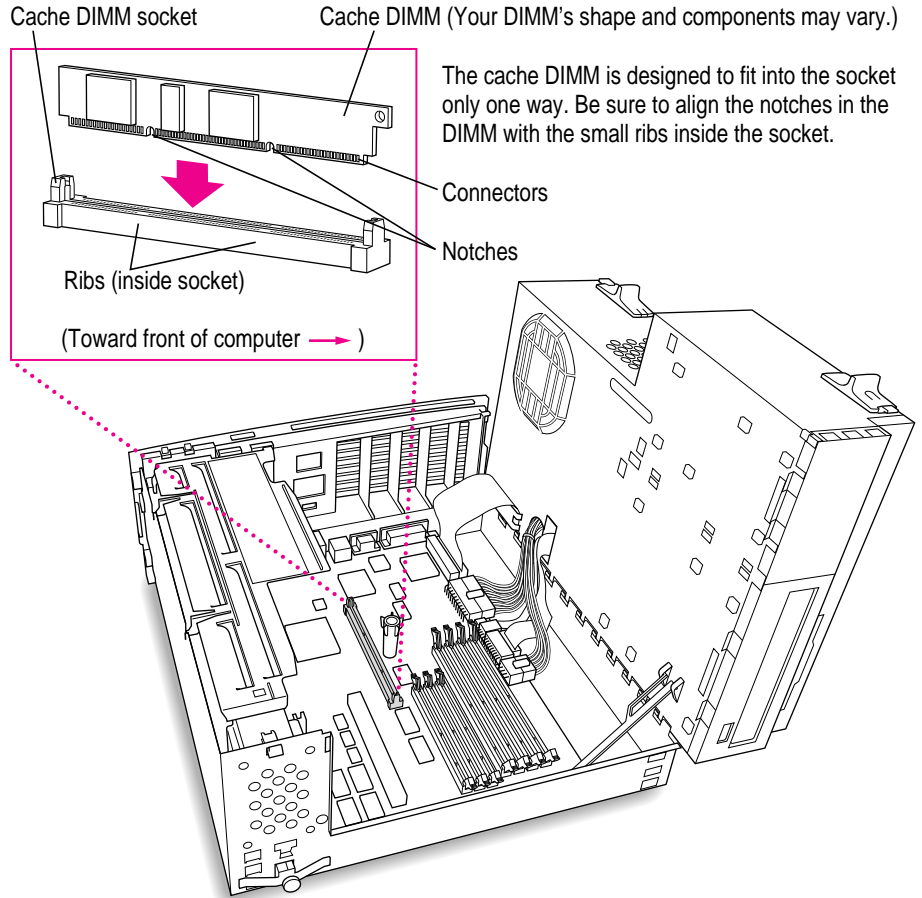

- 16** Replace the chassis by disengaging the support arm and gently swinging the chassis back into place.

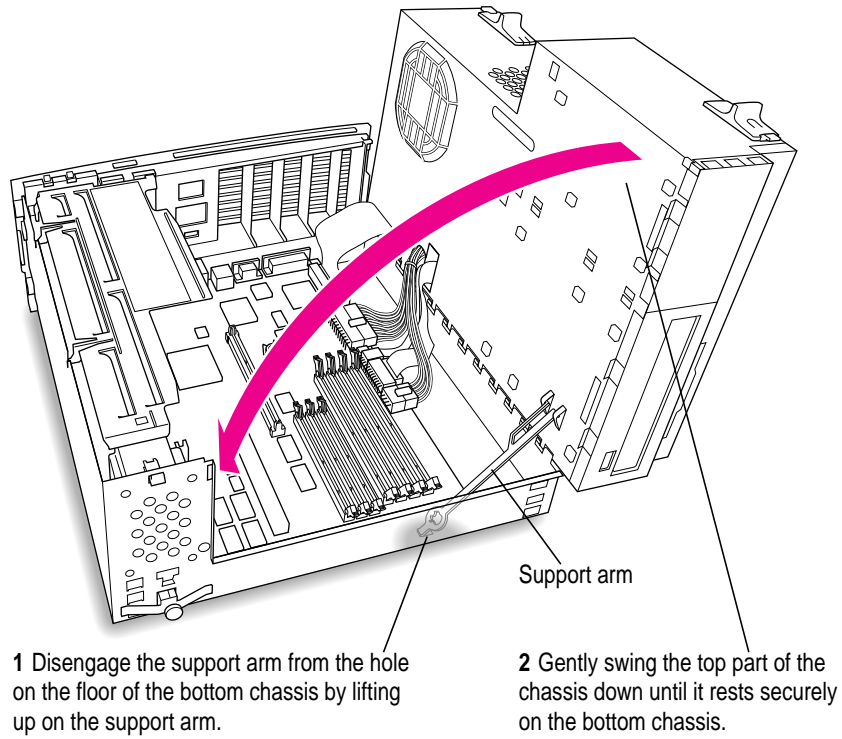

- 17** Lock the chassis back into place by pressing the release switches toward the outside of the computer.

Move the release switches toward the outside of the computer to lock the top chassis.

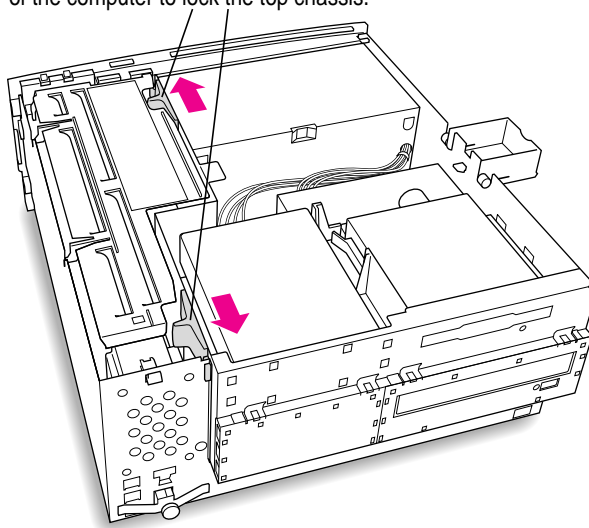

- 18** Unsnap the support foot and swing it back inside the computer housing.

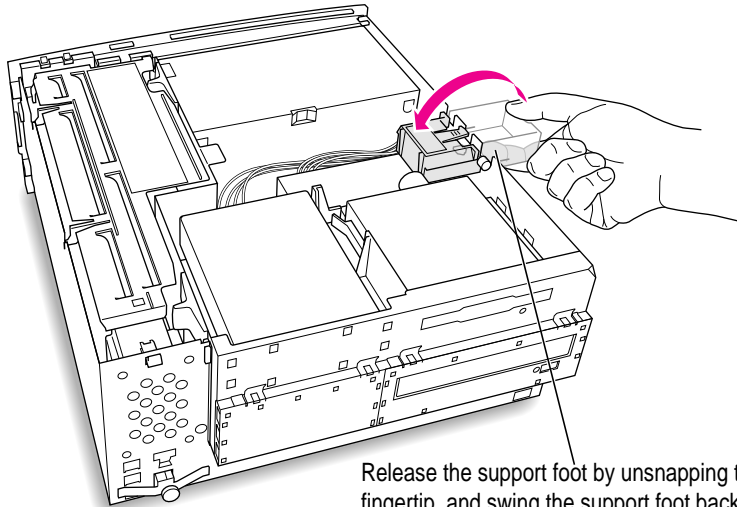

Release the support foot by unsnapping the catch with your fingertip, and swing the support foot back inside the chassis.

If you didn't remove an auxiliary fan before you installed DIMMs: Skip to step 20.

If you removed an auxiliary fan before you installed DIMMs: Continue with step 19.

19 Reconnect the auxiliary fan as described here.

- To locate the fan, flip open the expansion card cover.

Flip the expansion card cover open.

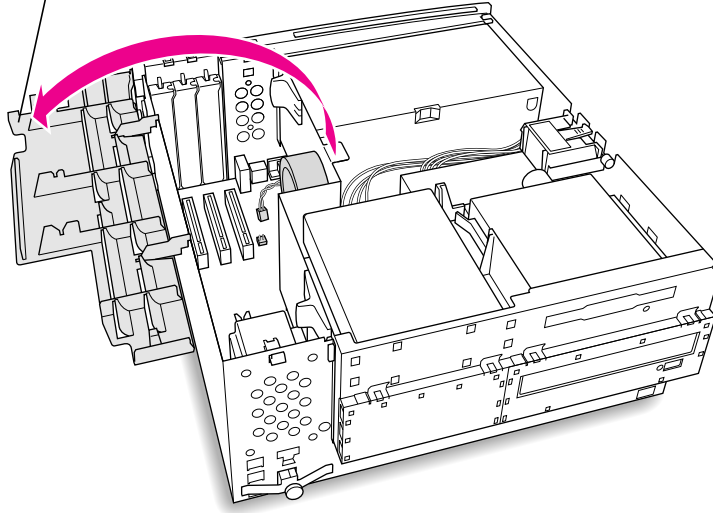

- Reconnect the auxiliary fan to the main logic board.
- Close the expansion card cover and snap it back into place.

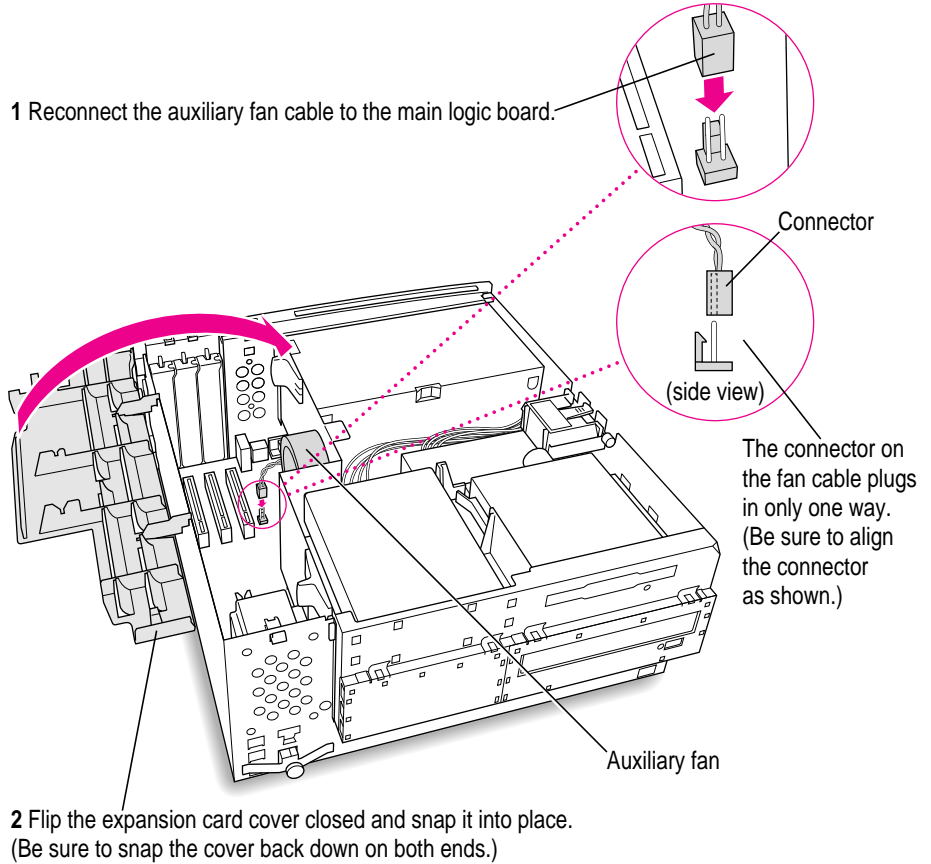

20 Replace the cover on the computer.

Lower the cover all the way down onto the case. Push the cover back until it snaps into place.

Set the top cover down so that there is about a two-inch gap between the back of the top cover and the back of the chassis.

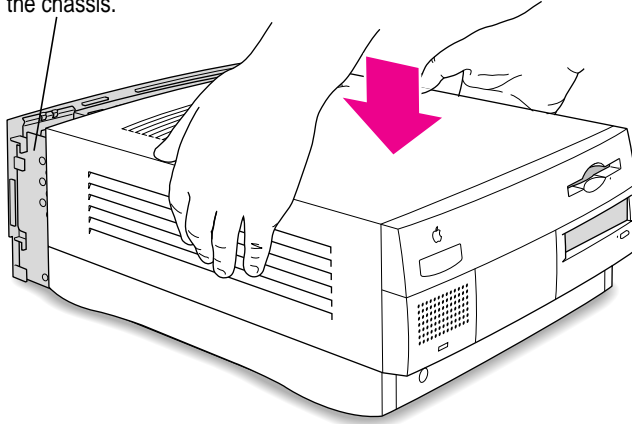

Slide the top cover all the way back until it snaps into place.

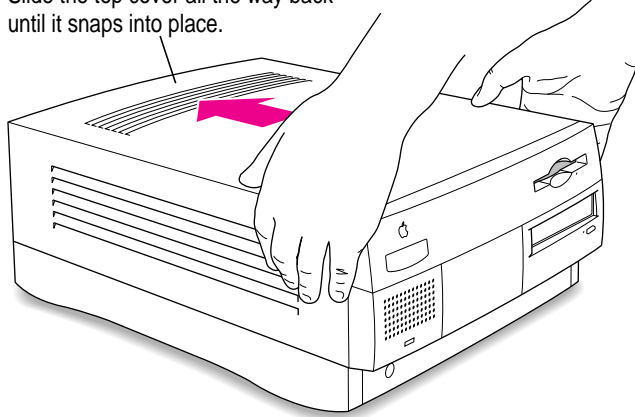

Graphics modes

The table below shows the image size for monitors (also called *displays*) that can be connected to the monitor port, along with the number of colors or grays supported with 1 MB of VRAM and with the optional expansion to 2 or 4 MB of VRAM. (You can place monitors weighing up to 52.3 lbs. on top of your computer.)

There are also many special monitor cards that can support other monitors and special video requirements. See your Apple-authorized dealer for information.

Note: On some monitors from manufacturers other than Apple, the connector pinout designates one pin for both green video and timing synchronization. These “sync on green” monitors are not compatible with Power Macintosh computers. If you’re not sure what type of monitor you have, check with your dealer.

Colors or grays supported

Monitor	VIS*	Resolution	Colors or grays supported			Screen refresh rates	
			1 MB VRAM max colors**	2 MB VRAM max colors**	4 MB VRAM max colors**	Vertical	Horizontal
12" RGB	N/A	512 by 384	millions	millions	millions	60 Hz	24.5 kHz
12" Monochrome	N/A	640 by 480	thousands	millions	millions	67 Hz	35 kHz
13" Hi-Res	N/A	640 by 480	thousands	millions	millions	67 Hz	35 kHz
14" RGB Hi-Res	11.5"	640 by 480	thousands	millions	millions	67 Hz	35 kHz
VESA Standard	***	640 by 480	thousands	millions	millions	60 Hz	31.5 kHz
		800 by 600	thousands	millions	millions	60 Hz	37.9 kHz
		800 by 600	thousands	millions	millions	72 Hz	48.1 kHz
		800 by 600	thousands	millions	millions	75 Hz	46.9 kHz
		1024 by 768	256	thousands	millions	60 Hz	48.4 kHz
		1024 by 768	256	thousands	millions	72 Hz	60 kHz
		1024 by 768	256	thousands	millions	75 Hz	80 kHz
		1280 by 1024	N/A	256	thousands	75 Hz	79.976 kHz
Full-page Monochrome	N/A	640 by 870	256	256	256	75 Hz	68.9 kHz
Full-page RGB	***	640 by 870	256	thousands	millions	75 Hz	68.9 kHz
14" AudioVision	11.5"	640 by 480	thousands	millions	millions	67 Hz	35 kHz

continued ►

Monitor	VIS*	Resolution	1 MB VRAM	2 MB VRAM	4 MB VRAM	Screen refresh rates	
			max colors**	max colors**	max colors**	Vertical	Horizontal
16" Color	14.8"	832 by 624	thousands	millions	millions	75 Hz	49.7 kHz
19" Color	***	1024 by 768	256	thousands	millions	75 Hz	60.24 kHz
Two-page Monochrome	N/A	1152 by 870	256	256	256	75 Hz	68.7 kHz
Two-page RGB	11.5"	1152 by 870	256	thousands	thousands	75 Hz	68.7 kHz
Multiple Scan 15	13.3"	640 by 480	thousands	millions	millions	66.7 Hz	35 kHz
		832 by 624	thousands	millions	millions	75 Hz	49.7 kHz
Multiple Scan 17	16.1"	640 by 480	thousands	millions	millions	67 Hz	35 kHz
		832 by 624	thousands	millions	millions	75 Hz	49.7 kHz
		1024 by 768	256	thousands	millions	75 Hz	60.24 kHz
Multiple Scan 20	19.1"	640 by 480	thousands	millions	millions	67 Hz	35 kHz
		832 by 624	thousands	millions	millions	75 Hz	49.7 kHz
		1024 by 768	256	thousands	millions	75 Hz	60.24 kHz
		1152 by 870	256	thousands	thousands	75 Hz	68.7 kHz
		1280 by 1024	N/A	256	thousands	75 Hz	79.976 kHz
		1280 by 960	N/A	256	thousands	75 Hz	68.7 kHz
21" color	***	1152 by 870	256	thousands	thousands	75 Hz	68.7 kHz
NTSC (underscan)	—	512 by 384	thousands	millions	millions	60 Hz	15.7 kHz
NTSC (overscan)	—	640 by 480	thousands	millions	millions	60 Hz	15.7 kHz
PAL (underscan)	—	640 by 480	thousands	millions	millions	50 Hz	15.625 kHz
PAL (overscan)	—	768 by 576	thousands	millions	millions	50 Hz	15.625 kHz

*Viewable image size

**256=image depth of 8 bits, thousands=image depth of 16 bits, millions=image depth of 32 bits

***Refer to the manual that came with your monitor to determine VIS.

N/A=not applicable



Internal disk drives

The following drives come factory-installed in your computer:

- Apple SuperDrive 1.4 MB high-density floppy disk drive
- Apple SCSI hard disk drive (different capacities are available)

Some Power Macintosh computers have an optional built-in CD-ROM drive:

- Optional internal, 5.25-inch, 1/2-height 4X-speed CD-ROM drive (a 1/2-height drive is 49 mm, or approximately 2 inches tall)

You can have additional internal drives installed by an Apple-authorized dealer or service provider.

Clock/calendar

- CMOS custom circuitry with long-life lithium or alkaline battery

Keyboard

- Supports all Apple ADB keyboards

Mouse

- Supports all models of the Apple ADB mouse

Interfaces

- One Apple Desktop Bus (ADB) port supports a keyboard, mouse, and other devices daisy-chained through a low-speed, synchronous serial bus (recommended maximum of three devices).
- Monitor port supports color and grayscale monitors of various sizes and resolutions. (See “Graphics Modes” earlier in this booklet.)
- Internal expansion card slots support three Peripheral Component Interconnect (PCI) expansion cards. Install only expansion cards that come with Macintosh drivers and are compliant with the PCI 2.0 standard. NuBus™ cards cannot be used in these expansion slots.
- Two RS-232/RS-422 serial GeoPort-compatible serial ports, 230.4 Kbit per second maximum (up to 2.048 Mbit per second if clocked externally).

- One built-in Ethernet 10BASE-T connector for direct connection to 10BASE-T networks. (If both AAUI and 10BASE-T connectors are plugged in, the computer uses the 10BASE-T connector by default.)
- One built-in Ethernet AAUI connector for connecting to high-speed Ethernet networks. Requires the appropriate AAUI transceiver adapter (10BASE-T, thin coaxial, or thick coaxial).
- One 3.5 mm sound output port for headphones or line-level devices.
- One 3.5 mm sound input port for stereo sound input. The sound input port supports the Apple PlainTalk Microphone that comes with some Macintosh computers. The sound input port also supports a standard stereo (miniplug-to-RCA) cable adapter for connecting stereo equipment to your computer. It does not support the omnidirectional microphone (the round microphone shipped with some earlier models of Macintosh) or the attenuated RCA adapter provided with some models of Macintosh.
- One SCSI interface that supports up to seven internal or external SCSI devices. The internal hard disk and optional CD-ROM drive are connected to this interface. An additional internal SCSI device can be connected to this interface by an Apple-authorized dealer or service provider.

IMPORTANT Some older SCSI devices may require updated drivers. (A “driver” is special software that is installed in your System Folder.) Contact the device manufacturer for information on obtaining driver software.

IMPORTANT The factory-installed internal hard disk is terminated. If another SCSI device is attached to the SCSI interface, it must not be terminated. The SCSI interface can contain only one terminated device; if you attach more than one terminated device to the internal SCSI interface, damage to the computer’s main logic board can occur.



Audio system

- Custom sound circuitry, including stereo generator (digital-to-analog converter, or DAC)—capable of driving stereo miniplug headphones or audio equipment—and stereo sampling hardware (analog-to-digital converter, or ADC) for recording stereo sound
- 16-bit stereo input and output
- Sample rates of 44.1 and 22.05 kilohertz (kHz) (If you installed the PlainTalk speech recognition software, the 44.1-kHz setting should not be used in conjunction with the Speech Setup control panel. Set the sample rate to 22.05 kHz when using the PlainTalk speech recognition software.)
- Input line level: 2 volts peak-to-peak nominal, into 6.5-Kilohm ($k\Omega$) impedance
- Output line level: 2.2 volts peak-to-peak nominal, into 1 $k\Omega$ impedance
- Input through output SNR*: >74 decibels (dB) typical
- Bandwidth: 10 Hz–19 kHz (+/- 2 dB) at 44.100 kHz sample rate
- THD+N*: Less than 0.06%; measured 30 Hz–16 kHz with a 2-Vpp sine wave input

*SNR is signal-to-noise ratio; THD+N is total harmonic distortion plus noise.

AC line input

WARNING To avoid damage to the computer, the voltage switch on the back of the computer must be set for the type of voltage system it will be connected to. If you don't know the voltage used in the country you're in, refer to the table, "Voltages for Different Locations" in the manual that came with your computer.

Note: Setting the correct voltage for your computer does not set the voltage for your monitor even if its power cord is connected directly to your computer. To protect your monitor, be sure to use the appropriate adapter or voltage converter.

Check to see that the voltage switch on the back of your computer is properly set before you plug it in. If you need to change the setting, insert a small screwdriver here and slide the switch.

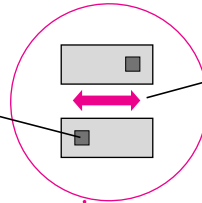

Set the switch to show "115" for voltages in the 100–130V range.
Set the switch to show "230" for voltages in the 220–270V range.

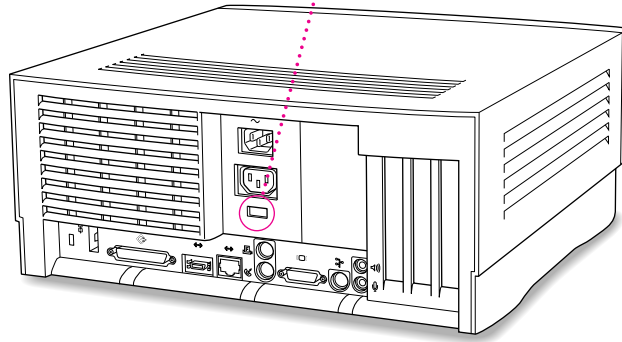

- Line voltage: 100–130 volts AC and 220–270 volts AC, RMS single phase, manually configured
- Frequency: 50–60 Hz
- Power: 215 watts maximum continuous; 300 watts peak input

AC line output

- Output receptacle: 100–270 volts (V) alternating current (AC), RMS (determined by actual input voltage); 3 ampere (A) maximum



DC power

- Continuous output: 150 watts
- Peak output (for 12 seconds at startup): 189 watts

Current type	Total*
+5 V	20 A*
+5 V (trickle)	0.1 A
+3.3 V	10 A*
+12 V	2.7 A*
-12 V	0.75 A

*Note: These items are interrelated—the maximum power available depends on the maximums used by other items. Combined power usage cannot be more than 20–25 A.

For example, you could have power output divided as shown in any of the three cases in the table below:

+3.3 V	+5 V	+5 V (trickle)	+12 V	-12 V	Total power consumption
0.0 A	20.0 A	0.10 A	3.375 A	0.75 A	150 W
0.0 A	16.1 A	0.10 A	5.0 A	0.75 A	150 W
10.0 A	15.0 A	0.10 A	2.70 A	0.75 A	150 W

Power requirements for devices you can connect

Apple Desktop Bus

- Mouse draws up to 10 mA.
- Keyboard draws 25–80 mA (varies with keyboard model used).
- Maximum current available for all ADB devices: 500 mA.

Note: The ADB port can support up to three ADB devices.

Audio and telecommunications devices

Power allowances for external devices connected to input ports:

Device	Voltage	Current	Power
Microphone	+5 V	20 mA	100 mW
GeoPort telecom adapter	+5 V	500 mA	2.5 W

Expansion cards and devices

If you add an expansion card, a 5.25-inch storage device, or a 3.5-inch storage device to your Power Macintosh computer, make sure the component's power requirements don't exceed the maximum power allowances allocated to it by the computer.

The maximum power allowances for expansion cards in your computer can accommodate three 15-watt or two 25-watt cards. Detailed guidelines are presented in the following table.

Device	Voltage	Current	Power
Expansion card (15 watts)*	+5 V	3 A	15 W
	+3.3 V	2 A	6.6 W
Expansion card (25 watts)**	+5 V	5 A	25 W
	+3.3 V	2 A	6.6 W
Storage device (such as a CD-ROM drive)	+5 V	9 A	45 W

*15-watt expansion cards should not consume more than 15 watts of power total.

**25-watt cards should not consume more than 25 watts of power total.

Assigning SCSI ID numbers

Your computer has a SCSI chain that can be used to connect one additional internal SCSI device and several additional external SCSI devices. All devices on the same SCSI chain must have unique ID numbers.

The drives that were installed in your computer at the factory, as well as the computer itself, have already reserved certain SCSI ID numbers. Other ID numbers are available for assignment to SCSI devices that are added after you buy your computer, as described in the following table.

SCSI ID number	Device
0	factory-installed hard disk
1	available
2	available
3	factory-installed CD-ROM drive
4	available
5	available
6	available
7	Power Macintosh computer



Size and weight

Weight	Height	Width	Depth
Main unit			
10 kg*	156 mm	365 mm	430 mm
22 lb.*	6.15 in.	14.37 in.	16.93 in.
Mouse			
0.11 kg	33 mm	61 mm	107 mm
4 oz.	1.3 in.	2.4 in.	4.2 in.

*Weight varies depending on type of hard disk and may be greater if a 5.25-inch device, such as a CD-ROM drive, is installed.

Maximum supportable monitor weight

- 52.3 lbs. (23.72 kg)

Environment

Operating temperature

- 10° C to 40° C (50° F to 104° F)

Storage temperature

- -40° C to 47° C (-40° F to 116.6° F)

Relative humidity

- 5% to 95% (noncondensing)

Altitude

- 0 to 3048 m (0 to 10,000 ft.)

Optional CD-ROM specifications

- Disc diameter 120 millimeters (5.25 inches)
and 80 mm
- Scanning velocity 1.2–1.4 meters per second
- Rotation speed Varies over radius
 - Normal speed ~530 to 230 rpm
 - Double speed ~1060 to 460 rpm
 - Quadruple speed ~2120 to 920 rpm
- Latency (average) Varies over radius
 - Normal speed ~55 to 130 milliseconds (ms)
 - Double speed ~27.5 to 65 ms
 - Quadruple speed ~13.75 to 32.5 ms
- Blocks per rotation ~8.4 to 19.5 variable
- Average access time (typical)
 - Normal speed 380 ms
 - Double speed 270 ms
 - Quadruple speed 200 ms

Data

- Data capacity 656 megabytes (MB), Mode 1
748 MB, Mode 2
- Number of blocks per disc 336,150
- Data per block 2048 bytes, Mode 1
2336 bytes, Mode 2
- Address description Minutes, seconds, blocks

Audio capacity

- Playing time 74 minutes, 42 seconds



Modes supported

- Audio CD
- CD-ROM Modes 1 and 2
- CD-ROM XA Mode 2, Forms 1 and 2
- CD-I Mode 2, Forms 1 and 2
- Photo CD Single session and multisession
- Video CD

Data streaming and transfer rates

- Blocks per second
 - Normal speed 75
 - Double speed 150
 - Quadruple speed 300
- User kilobytes (K) per second
 - Normal speed 150K, Mode 1
171.1K, Mode 2
 - Double speed 300K, Mode 1
342.2K, Mode 2
 - Quadruple speed 600K, Mode 1
684.4K, Mode 2
- SCSI bus burst rate (typical)
 - Asynchronous 5.0 MB per second
 - Synchronous 5.0 MB per second

Power consumption (typical)

+ 5 V DC	360 milliamperes (mA)
+12 V DC	620 mA

Laser

- Type: Semiconductor GaAlAs laser
- Wavelength: 790 ± 25 nanometers
- Output power: 0.2 to 0.6 milliwatts
- Beam divergence: 55°



© 1995 Apple Computer, Inc. All rights reserved. Apple, the Apple logo, Apple SuperDrive, GeoPort, Macintosh, PlainTalk, and Power Macintosh are trademarks of Apple Computer, Inc., registered in the U.S. and other countries. Apple Desktop Bus and AudioVision are trademarks of Apple Computer, Inc. NuBus is a trademark of Texas Instruments. PowerPC is a trademark of International Business Machines Corporation, used under license therefrom.

030-6955-A
Printed in U.S.A.