



Part I
Getting Started

Part II
Learning

Part III
Reference

Part IV
Index

Macintosh User's Guide

for Macintosh PowerBook 145B

Includes setup instructions and important health-related information

Apple Computer, Inc.

This manual and the software described in it are copyrighted, with all rights reserved. Under the copyright laws, this manual or the software may not be copied, in whole or part, without written consent of Apple, except in the normal use of the software or to make a backup copy of the software. The same proprietary and copyright notices must be affixed to any permitted copies as were affixed to the original. This exception does not allow copies to be made for others, whether or not sold, but all of the material purchased (with all backup copies) may be sold, given, or loaned to another person. Under the law, copying includes translating into another language or format.

You may use the software on any computer owned by you, but extra copies cannot be made for this purpose.

The Apple logo is a trademark of Apple Computer, Inc., registered in the U.S. and other countries. Use of the “keyboard” Apple logo (Option-Shift-K) for commercial purposes without the prior written consent of Apple may constitute trademark infringement and unfair competition in violation of federal and state laws.

© Apple Computer, Inc., 1993
20525 Mariani Avenue
Cupertino, CA 95014-6299
(408) 996-1010

Apple, the Apple logo, APDA, AppleLink, AppleShare, AppleTalk, ImageWriter, LaserWriter, LocalTalk, Macintosh, ProDOS, and StyleWriter are trademarks of Apple Computer, Inc., registered in the U.S. and other countries.

Apple Desktop Bus, Balloon Help, Chicago, Finder, Disk First Aid, Monaco, PowerBook, System 7, and TrueType are trademarks of Apple Computer, Inc.

AppleCare is a service mark of Apple Computer, Inc., registered in the U.S. and other countries.

Adobe, Adobe Illustrator, and PostScript are trademarks of Adobe Systems Incorporated, registered in the United States. Adobe Photoshop is a trademark of Adobe Systems Incorporated.

Classic is a registered trademark licensed to Apple Computer, Inc.

Exposure is a registered trademark of Preferred Publishers, Inc.

Helvetica and Times are registered trademarks of Linotype Company.

ITC Garamond is a registered trademark of International Typeface Corporation.

MacWrite is a registered trademark of Claris Corporation.

MS-DOS is a registered trademark of Microsoft Corporation.

QMS is a registered trademark and ColorScript is a trademark of QMS, Inc.

QuarkXPress is a registered trademark of Quark, Inc.

SelectSet is a trademark of Miles, Inc., Agfa Division.

SuperPaint is a registered trademark of Aldus Corporation.

Tektronix is a registered trademark and Phaser is a trademark of Tektronix, Inc.

Simultaneously published in the United States and Canada.

Mention of third-party products is for informational purposes only and constitutes neither an endorsement nor a recommendation. Apple assumes no responsibility with regard to the performance or use of these products.

Contents

Radio and television interference xiv

Preface How to Use This Book xv

■ **Part I** *Getting Started With Your Computer* 1

Chapter 1 Setting Up Your Macintosh PowerBook 1

Setting up the computer 2

Step 1: Plug in the power adapter 2

Step 2: Open the display 3

Step 3: Turn on the computer 4

Trouble? 5

What to do next 6

Your computer at a glance 7

Backing up your hard disk 8

Why back up? 8

What you need 9

Make the copy 10

If something happens to your hard disk 12

Turning the Powerbook on and off 13

Off 13

Sleep 14

On 15

On/off summary 15

When you turn on your computer 16

Restarting a computer that's already on 17

Restarting a computer that can't be turned on normally 17

Learning the basics	19
Before you begin	19
Finding the tour	20
Starting the tour from the hard disk	20
Starting the tour from a floppy disk	24
Important care and safety instructions	26
▲ Warning	26
▲ Caution	27
△ Important	28
Health concerns associated with computer use	29
Repetitive stress injuries	30
Arranging your work space and equipment	31

■ Part II *Learning Macintosh* 35

Chapter 2 Working on the Desktop 35

Use the trackball	36
Point	36
Click	37
Press	38
Drag	39
Choose a command	40
<i>Giving orders to your computer</i>	40
Open an icon	41
Look at the contents of a window	42
Make a window the active window	42
Make a window larger or smaller	44
Move the hidden contents of a window into view	46
Close a window	48
Move a window	49
<i>What's on the desktop?</i>	50
<i>Using the keyboard</i>	53

Chapter 3 Creating and Changing a Document 55

Open a program 56

Create a document 57

Save your work 57

Switch programs 58

Close a document 60

Two types of programs 61

Open a document 61

Change a document 62

Save your work so far 65

Taking a shortcut 66

Make more changes 66

Quit a program 68

Opening and closing documents and programs 69

Make a copy of a document 69

Change the name of an icon 70

Use the Trash 71

Chapter 4 Working With Disks 73

Insert a floppy disk 74

Floppy disks and hard disks 75

Initialize a disk 76

Copy the contents of a disk 78

Taking care of floppy disks 79

Take a floppy disk out of its drive 80

Protect the contents of disk 81

On your own: Install your programs 82

Throw away extra System Folders 83

Chapter 5 Learning More About Your Computer 85

Open the Battery desk accessory 86

Open the PowerBook control panel 86

Use Balloon Help 87

Turn on Balloon Help 87

Turn off Balloon Help 88

Use Part III of this book 89

What next? 89

■ Part III *Macintosh Reference* 91

Chapter 6 Setting Up Your Programs 91

- Reminder: Back up 91
- Reinstalling system software 91
- Installing your programs 92
 - Installing programs without a floppy disk drive 92
- Installing system software from floppy disks 93
- Checking for computer viruses 94
- Working with several programs at a time 95
 - Finding out what programs are open 95
 - Switching programs 96
 - Hiding and showing windows on the desktop 96
 - Changing the amount of memory a program uses 97
- Using the Scrapbook 98
 - Storing items in the Scrapbook 98
 - Copying items from the Scrapbook 98
 - Deleting items from the Scrapbook 98

- Using a RAM disk 99
 - Creating a RAM disk 99
 - Erasing a RAM disk 100
 - Resizing or removing a RAM disk 100

Chapter 7 Power Management 101

- Monitoring the battery charge level 101
 - Using the battery desk accessory 101
 - Responding to low-power messages 102
- Recharging the battery 103
 - Recharging with the power adapter 103
 - Recharging with a recharger 105
- Removing or replacing the battery 106
- Maximizing battery life 108
- Maximizing work time 109
 - Ways to conserve battery power 109
 - Adjusting the battery conservation settings 110
 - Using the battery conservation options 111

Chapter 8 Using Disks 113

- Preparing a new disk for use 113
 - Initializing a hard disk 113
 - Initializing a floppy disk 115
- Erasing a floppy disk 116
- Designating a startup disk 116
 - Scanning order for startup disks 117
- Protecting the information on a disk 117
 - Locking a floppy disk 117
 - Locking a file 118
 - Backing up your files 119
- Restoring the information on your hard disk 123
 - Restoring your System Folder 125
- If you can't save files on a floppy disk 125
- Ejecting a disk 126
 - If you can't eject a floppy disk 126

Caring for disks 127

Hard disk precautions 127

Testing and repairing disks 127

If a hard disk icon doesn't appear 127

Using Disk First Aid 128

Testing a hard disk 130

Chapter 9 Organizing Your Files 125

Straightening up your files 131

Using folders to organize your files 132

Creating and naming folders 132

Filing documents when you save them 133

Making items easier to find 134

Creating an alias 134

Installing an item in the Apple menu 135

Moving an item to the desktop 135

Finding an item	136
Finding an item by name	136
Finding an item using other criteria	137
Finding items that meet two criteria	139
Ways to use the Find command	139
Creating a template or stationery	140
Getting information about your files	141
Using the Info window	141
Using the View menu	142
Assigning a label to a file	142
Tips on transferring files	143

Chapter 10 Adapting Your Computer to Your Own Use 145

Specifying which items you want opened at startup	146
Installing an item in the Apple menu	146
Installing files in the System Folder	146
Removing files from the System Folder	147

Changing the items in the Label menu	148
Setting the time and date	148
Setting a time for the Alarm Clock to go off	149
Turning the alarm off	150
Changing time and date formats	150
Changing the date format	151
Changing the time format	152
Changing number and currency formats	153
Adjusting the way the trackball or mouse works	154
Adjusting the way the keyboard works	155
Making keyboard shortcuts easier to type	156
Adjusting the keyboard for very slow typing	156
Adjusting the blinking of a menu item	157
Adjusting the blinking of the insertion point	157
Changing the way the contents of windows appear	158
Changing an icon	159
Turning off the Empty Trash warning	160

- Managing memory 161
 - Checking memory use 161
 - Making the most of your memory 162
 - Adjusting the disk cache 162
 - Using hard disk space as memory 163
 - Turning on 32-bit addressing 164
- Setting the beep sound 165
- Installing a sound 166
- Removing a sound 166
- Recording sounds 167
- Changing the background pattern 168
- Magnifying the screen image 170

Chapter 11 Printing 173

- Before you print 173
 - Choosing a printer 173
 - Selecting Page Setup options 176
 - Updating printer software on networked computers 177

- Printing your work 178
 - Printing the contents of a window or the desktop 179
 - Solutions to common printing problems 180
- Controlling background printing 181
- Working with fonts 182
 - Outline fonts and bitmap fonts 182
 - Installing fonts 183
 - Removing fonts 184
 - Transferring fonts to a LaserWriter printer 184
 - Finding out about available fonts 186
 - Other ways to use the LaserWriter Font Utility 186

Chapter 12 Using Your Computer on a Network 189

- What networking offers 189
- Setting up your computer on a network 189
 - Connecting to a network 191
 - Turning on AppleTalk 191
 - Naming your computer and its owner 192

Gaining access to files on shared disks	193	Setting a registered user's password	204
Before you begin	193	Naming a group of users	204
Connecting to a shared disk	193	Seeing who's in a group	205
Disconnecting from a shared disk	195	Selecting a user or group to share a folder or disk	206
Connecting quickly to a shared disk	196	Preventing specific users or guests from accessing your computer	207
Connecting automatically when you start up	196	Removing a user from a group	208
Working with files and folders on other computers	197	Removing a user or group from your list of registered users	208
Creating a new folder on another computer	197	Giving away ownership of a folder or disk on your computer	209
Changing your password	197	Turning file sharing off	209
Giving folder ownership to someone else	199	Monitoring file-sharing activity	210
Sharing your own files	199	Disconnecting someone who is connected to your computer	211
How file sharing works	199	Gaining access to your computer from another computer	211
Turning file sharing on	200	Changing your password	212
Turning on guest access	200		
Selecting a folder or disk to share	201		
Naming a registered user	203		

- Using access privileges 213
 - Understanding access privileges 213
 - Setting access privileges to folders and disks 214
 - Access privilege strategies 215
 - Working with privileges others have set 217
 - Checking your access privileges 217
- Linking programs 218
 - Linking to a program on another computer 218
 - Disconnecting a program link 219
 - Allowing other people to link to your programs 219

Chapter 13 Expanding Your Computer System 223

- Using SCSI devices 223
 - Installing software 224
 - Setting SCSI ID numbers 224
 - Checking that the SCSI chain is properly terminated 226
 - Connecting cables 227

- Connecting a modem 228
- Connecting a printer 229
- Connecting a mouse or other ADB device 229
- Using sound input and output devices 230
 - Connecting a microphone 230
 - Sound output devices 230
- Adding memory to your computer 231

Chapter 14 Travel, Storage, and Service 233

- Traveling with the PowerBook 233
- Storing the PowerBook 234
 - Short-term storage (up to 2 weeks) 234
 - Long-term storage (more than 2 weeks) 234
- Service and support 235
 - If the PowerBook malfunctions or is damaged 235
 - How to get help 236
- For more information about Macintosh computers 237
 - Macintosh user groups 237
 - Technical information 237

Quick Reference Summary and Shortcuts 239

Double-click 236

Shift-click 239

Working with icons 239

 Selecting icons 239

 Opening an icon 240

 Moving, copying, and renaming an icon 240

Working with windows 240

 Making a window the active window 240

 Moving a window and changing its size 240

 Scrolling through the contents of a window 241

 Opening higher-level folder windows 241

 Using the outline form in list views 242

Working with menus 242

 Choosing an item from a menu 243

 Choosing an item from a submenu 243

Keyboard shortcuts in the Finder and in directory dialog boxes 244

Troubleshooting 245

 The PowerBook 245

 Power 247

 The screen 249

 Memory 250

 SCSI devices 250

 Disk drives and disks 251

 Modems 254

 Printers 254

 Networks 256

 Application programs 257

Appendix A Keyboard and Character Sets 259

Using Caps Lock 260

Typing special characters and symbols 260

Appendix B Exchanging Disks and Files with MS-DOS Computers 263

Initializing a disk in MS-DOS format 263

Converting files to and from MS-DOS format 265

Other file-conversion options 267

Appendix C Map 269

Setting your location 269

Comparing locations 270

Finding a location 271

Adding or removing a location 272

Adding a location 272

Changing or removing a location 272

■ Part IV *Index* 275

Radio and television interference

The equipment described in this manual generates, uses, and can radiate radio-frequency energy. If it is not installed and used properly—that is, in strict accordance with Apple’s instructions—it may cause interference with radio and television reception.

This equipment has been tested and found to comply with the limits for a Class B digital device in accordance with the specifications in Part 15 of FCC rules. These specifications are designed to provide reasonable protection against such interference in a residential installation. However, there is no guarantee that the interference will not occur in a particular installation.

You can determine whether your computer system is causing interference by turning it off. If the interference stops, it was probably caused by the computer or one of the peripheral devices.

If your computer system does cause interference to radio or television reception, try to correct the interference by using one or more of the following measures:

- Turn the television or radio antenna until the interference stops.
- Move the computer to one side or the other of the television or radio.
- Move the computer farther away from the television or radio.
- Plug the computer into an outlet that is on a different circuit from the television or radio. (That is, make certain the computer and the television or radio are on circuits controlled by different circuit breakers or fuses.)

If necessary, consult your authorized Apple dealer or an experienced radio/television technician for additional suggestions. You may find helpful the following booklet, prepared by the Federal Communications Commission: *Interference Handbook* (stock number 004-000-00345-4). This booklet is available from the U.S. Government Printing Office, Washington, DC 20402.

△ Important: Changes or modifications to this product not authorized by Apple Computer, Inc., could void the FCC Certification and negate your authority to operate the product.

This product was tested for FCC compliance under conditions that included the use of shielded cables and connectors between system components. It is important that you use shielded cables and connectors to reduce the possibility of causing interference to radios, television sets, and other electronic devices. For Apple peripheral devices, you can obtain the proper shielded cables from your authorized Apple dealer. For non-Apple peripheral devices, contact the manufacturer or dealer for assistance. △

Important

This equipment has been tested and found to comply with the limits for a Class B digital device in accordance with the specifications in Part 15 of FCC rules. See instructions if interference to radio or television reception is suspected.

DOC Class B Compliance This digital apparatus does not exceed the Class B limits for radio noise emissions from digital apparatus set out in the radio interference regulations of the Canadian Department of Communications.

Observation des normes—Classe B Le présent appareil numérique n’émet pas de bruits radioélectriques dépassant les limites applicables aux appareils numériques de la Classe B prescrites dans les règlements sur le brouillage radioélectrique édictés par le Ministère des Communications du Canada.

情報処理装置等電波障害自主規制について

この装置は、第二種情報装置（住宅地域又はその隣接した地域において使用されるべき情報装置）で住宅地域での電波障害防止を目的とした情報処理装置等電波障害自主規制協議会（VCCI）基準に適合しております。

しかし、本装置をラジオ、テレビジョン受信機に近接してご使用になると、受信障害の原因となることがあります。

取扱説明書に従って正しい取り扱いをしてください。

How to Use This Book

This book has several parts.

- Chapter 1 explains how to set up your computer and learn how to use it.
- Chapters 2–5 are a tutorial designed for people who have not used a Macintosh computer before. If you are new to the Macintosh, you should read this section of the book before you start your own work.
- Chapters 6–14 contain reference information that will help you as you become more proficient with your computer. You can turn to these chapters for information about a particular topic.
- At the back of the book you'll find a troubleshooting section and an index.

Certain kinds of information are *not* included in this book.

- Information about modems. If your computer has a built-in modem, or if you purchase one later, you receive a separate modem manual with instructions for its use.
- Information about application programs. Your best source of information about a particular program is the set of books and disks that came with that program.
- Technical specifications for your PowerBook model. These are on a separate sheet in the box with your computer.

Turn now to Chapter 1 to set up your new PowerBook computer.

Welcome to Macintosh.

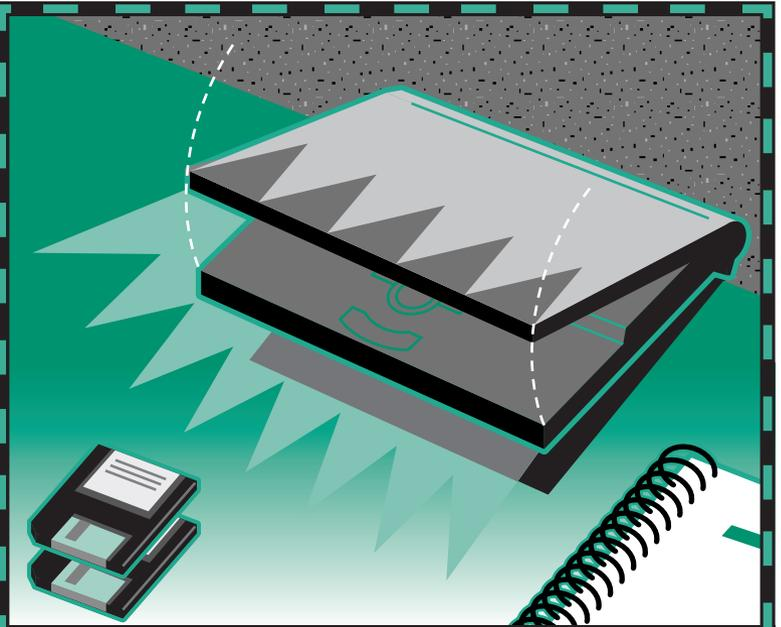
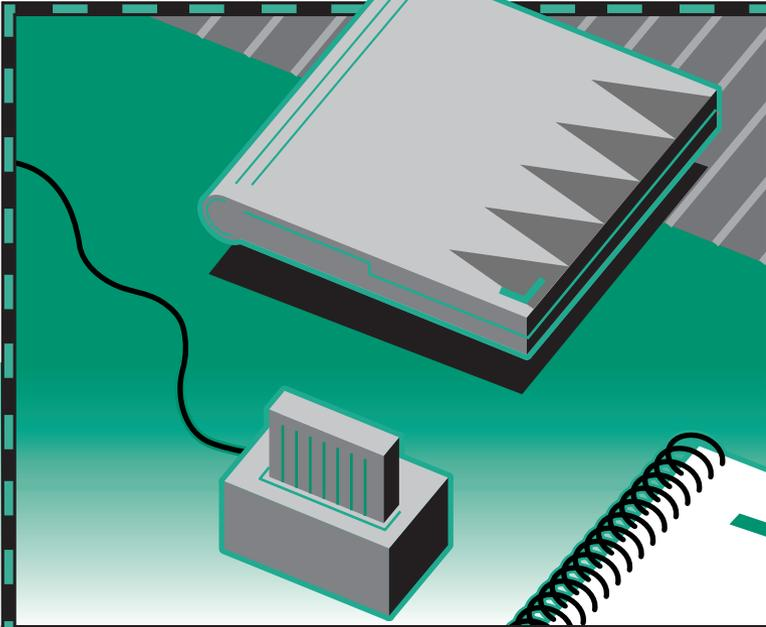

Chapter 1

Setting Up Your Macintosh PowerBook

In this chapter

- Setting up your computer
 - Backing up your computer's hard disk
 - Learning how to use your computer
 - Turning the computer on and off
 - Important care and safety instructions
 - Being comfortable while you work
- **New Macintosh users:** If you have never used a Macintosh computer before, read this entire chapter. It explains how to set up your computer, learn how to use it, and turn it on and off.
 - **New PowerBook users:** If you have used other Macintosh computers but are new to the PowerBook, follow the setup instructions that begin on the next page and then go to the section on backing up your computer's hard disk.
 - **Experienced PowerBook users:** Read the section on backing up your computer's hard disk. Skim this chapter for information that applies to your computer.
- △ **Important:** No matter what your level of experience, please read the safety information in this chapter before beginning your own work. This information can help protect you and your computer equipment from possible harm. △

Setting up the computer

Step 1: Plug in the power adapter

Plugging in the power adapter recharges the computer's battery while you work. You should plug it in now in case the battery has drained during shipping and storage.

- ▲ **Warning:** Use only the power adapter that came with your PowerBook computer. Adapters for other electronic devices (including other portable computers) may look similar, but they may damage your computer. ▲

- Plug the power adapter into a standard electrical outlet or power strip. Then plug the power adapter cable into the power adapter port (marked with the icon ) on the back panel of the computer.

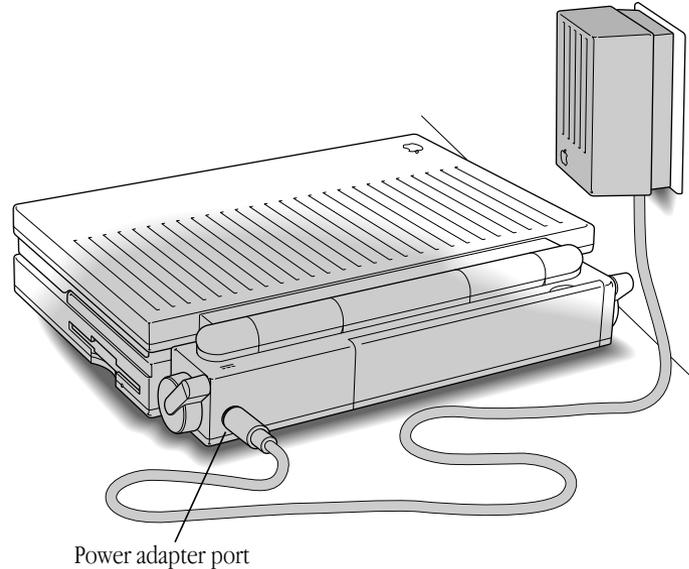

Step 2: Open the display

- Slide the latch to the right and lift up the display.

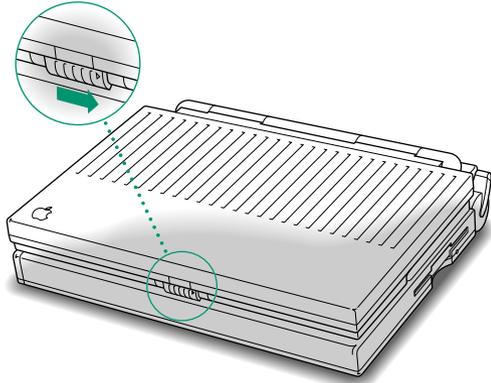

Position the display at a comfortable viewing angle. You can adjust the angle of the display at any time.

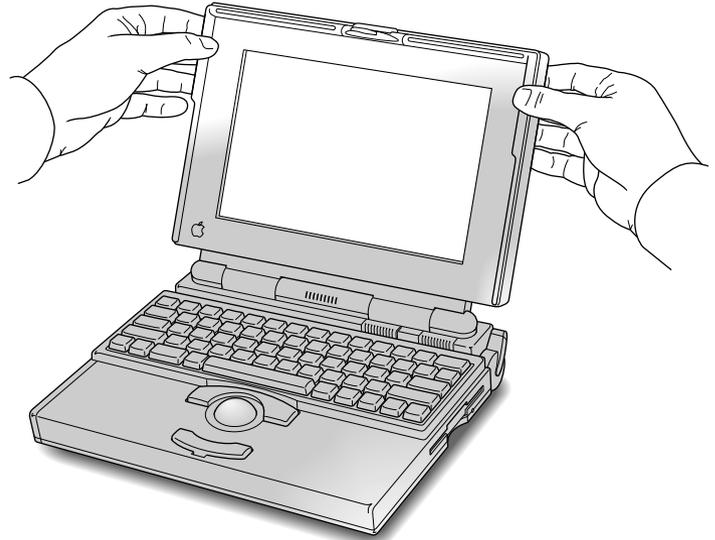

Step 3: Turn on the computer

- Open the door to the back panel of your computer.

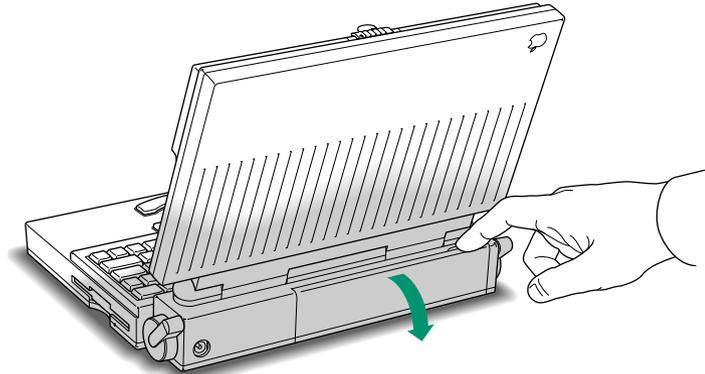

- Press the power button to turn the computer on. The power button has this icon: ①

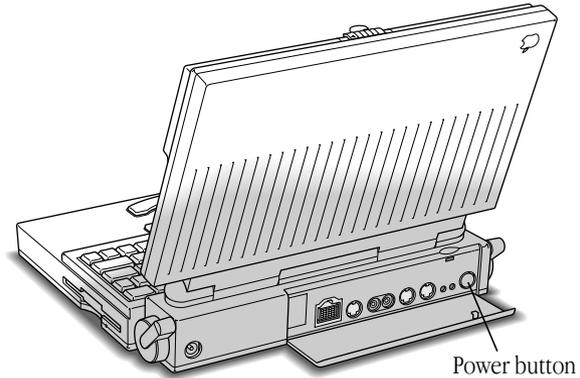

You hear a tone when you turn on the computer. It takes the computer a moment to start up.

You see the Macintosh desktop on your screen. The computer is ready to use. Continue with the section “What to Do Next.”

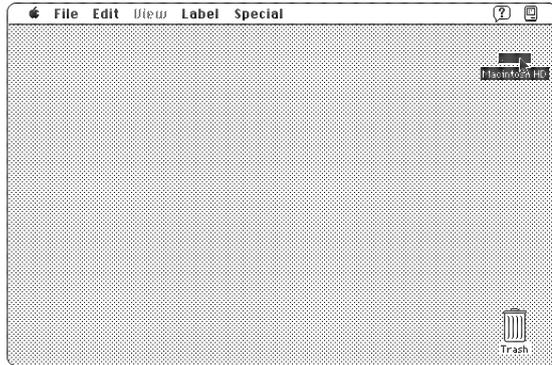

Trouble?

- *The computer made a sound, but you can't see anything on the screen.*

Adjust the brightness control (marked with the icon ☼) and the contrast control (●) until an image appears and the screen is easy to read.

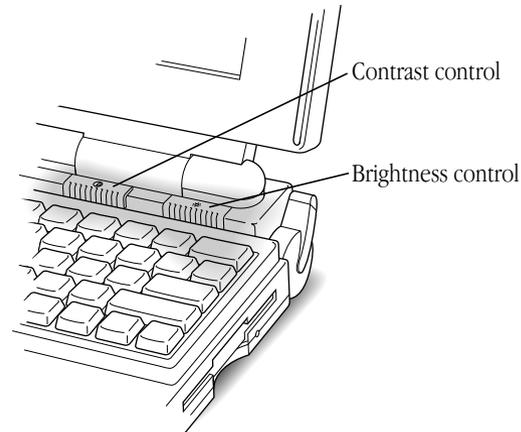

- *Nothing happened when you pressed the power button.*

Make sure the power adapter is firmly connected to both the computer and a power source. If the power adapter is plugged into a power strip, make sure the power strip is plugged in and turned on. Then try pressing the power button again.

What to do next

- If you have never used a Macintosh computer before, continue with the section “Learning the Basics.”
- Otherwise, continue with the section “Backing Up Your Hard Disk.” This section contains important information about protecting your software. Then go to “Turning the PowerBook On and Off.” This section contains information that can help you use your computer efficiently.
- Be sure to read the safety instructions and the section on health concerns before beginning to use your PowerBook.

△ **Important:** Even if you already know how to use Macintosh computers, be sure to read the section “Backing Up Your Hard Disk.” This section explains how to back up your software using the PowerBook 145B Backup application program. It is extremely important that you make a backup copy of your software on floppy disks in case something happens to your system. △

Your computer at a glance

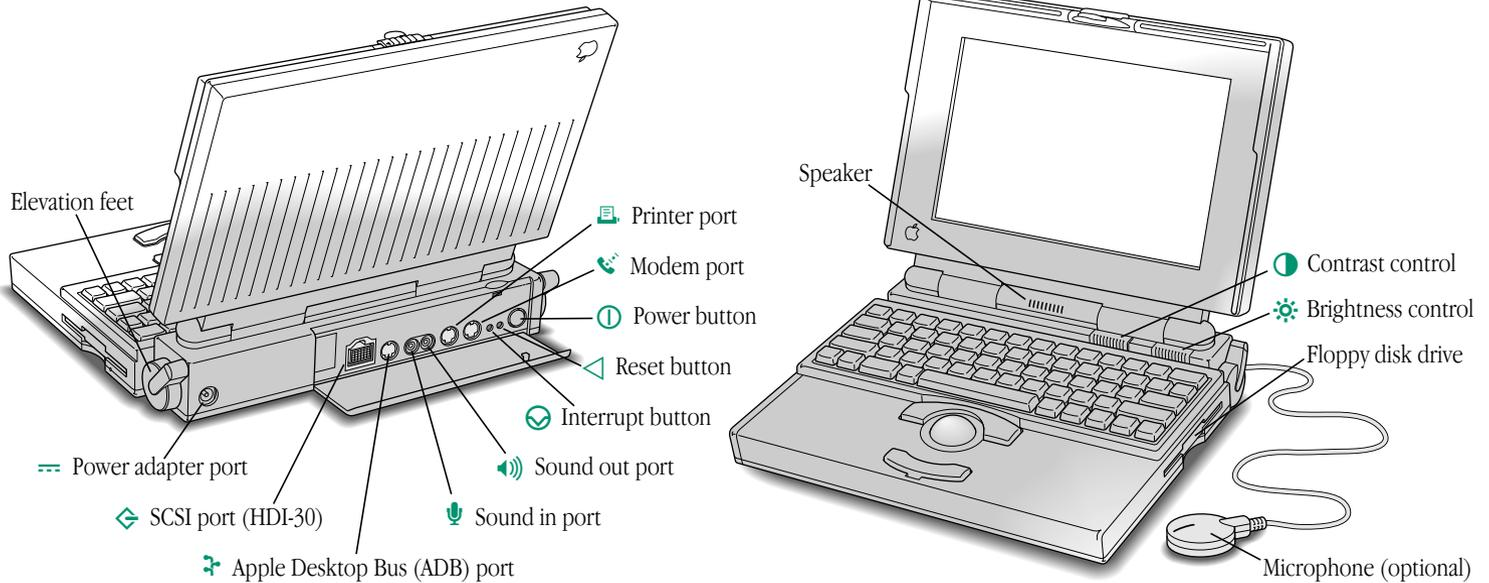

Backing up your hard disk

This section describes how to protect the software on your computer's hard disk.

Why back up?

Your computer's hard disk comes with valuable information stored on it, including the *system software* (which operates the computer) and some programs. You should make a copy of the information on your hard disk for safekeeping, using the PowerBook 145B Backup program supplied on your hard disk. (The extra copy is called a *backup*, and the process of making the copy is called *backing up*.)

You should also make a copy of your System Folder. If the System Folder on the hard disk becomes damaged, you can quickly restore it from your backup copy.

To restore information to your hard disk, you can use the PowerBook 145B Restore program that came with your Macintosh. See "Restoring the Information on Your Hard Disk" in Chapter 8.

What you need

Just as you'd need paper to make copies of important documents, you need floppy disks to copy the information on your hard disk. You can probably buy the floppy disks at the same place you bought the computer.

Floppy disks come in a variety of sizes and capacities. The ones you need for this chapter are called *high-density 3.5-inch disks*. You can recognize the disks by the way they look:

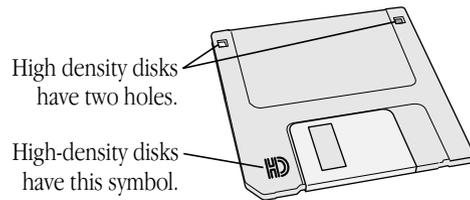

Even though these disks are called “floppy disks,” they aren’t actually floppy.

Depending on exactly what was installed on your computer at the factory, the information will fill between 10 and 20 high-density disks. Since disks usually come in boxes of ten, you should have two boxes of disks before starting the instructions.

If you don’t have enough disks, you can skip this section for the moment. But the sooner you make the backup copy, the better. Buy the disks as soon as possible, then follow the instructions in this chapter.

Make the copy

To start the PowerBook 145B Backup program, follow these instructions:

1. **Turn on your computer.**
2. **Open the PowerBook 145B Backup program by double-clicking its icon.**



After a moment, the PowerBook 145B Backup program opens.

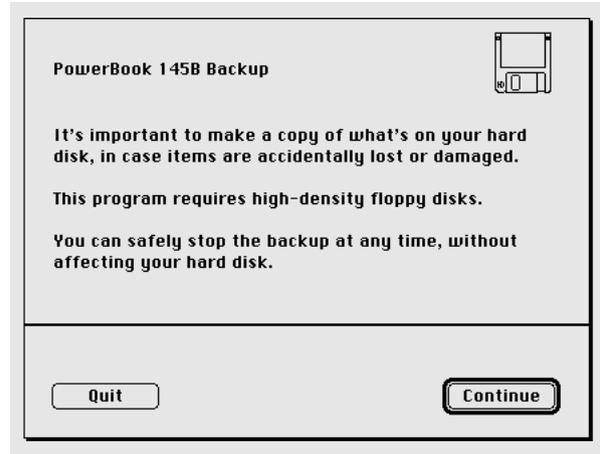

3. **Make sure your disks are high-density floppy disks. Then click the Continue button.**

A message appears, telling you how many floppy disks you need to make your backup copy and about how long it will take.

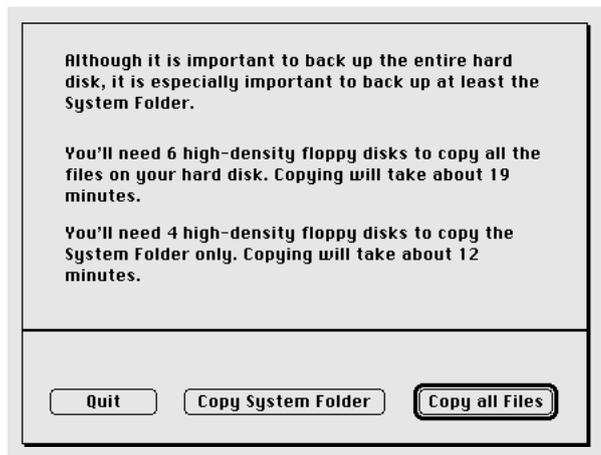

4. Click the appropriate choice, as follows:

- The first time through these instructions, click the Copy System Folder button.
- The second time through these instructions, click the Copy all Files button.
- If you don't have enough floppy disks for your choice, click Quit. Skip the rest of this section for now, and continue with "Turning the PowerBook On and Off." Buy floppy disks as soon as you can, then follow the instructions in this section to back up your important files.

Make sure you have enough time and floppy disks to complete the copying. If you stop the copying before it's finished, you'll have to start over again from the beginning.

5. Insert a high-density floppy disk into the disk drive.

Do not use the *Disk Tools* floppy disk that came with your computer.

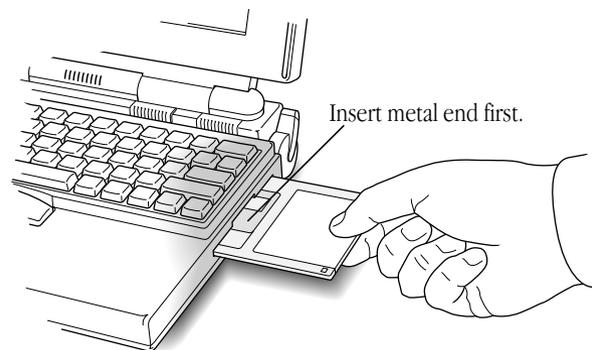

continues ►

- 6. Follow the instructions on the screen until a message tells you that you're finished. Remember to label each disk with the name displayed on the screen. The name will disappear as soon as the disk is ejected.**

Be sure to follow the labeling instructions so you can find the floppy disks again later.

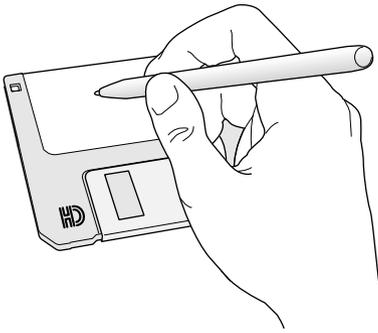

- 7. Follow steps 2-6 again, but this time click the Copy all Files button.**
- 8. When you're finished, be sure the floppy disks are properly labeled and locked, then store them in a safe, cool place.**

As time goes by, you will store more information on your computer. You should back up your hard disk at least once a month. If you wish, you can purchase a backup program with additional features that make copying faster. (For example, some programs have a feature that lets you copy only the new and changed information on your hard disk.)

If something happens to your hard disk

If something does happen to your hard disk, you can get all the original information back from your backup floppy disks. To do this, you use the PowerBook 145B Restore program that came with your Macintosh. See the chapter on disks in the reference section.

Turning the PowerBook on and off

Your Macintosh PowerBook can be in one of three power states: off, sleep, or on.

Off

When the PowerBook is off, the computer is not using any power or doing any work. The terms *shut down* and *off* both refer to this state.

You should turn the computer off to

- attach other equipment to it
- replace its battery
- conserve power when you won't be using it for several hours

To turn the PowerBook off

- If the computer is on, choose the Shut Down command from the Special menu. (The *Macintosh Basics* tour teaches how to choose a menu command.)



- If the computer is in sleep, wake it by pressing any key on the keyboard (except Caps Lock), and then choose Shut Down.
- △ **Important:** Don't shut down with the power button on the back panel of the computer unless a problem prevents you from choosing Shut Down. You will lose any work you did not save, and you may experience problems with your hard disk. △

Sleep

When the PowerBook is in sleep, it draws enough power to maintain the information in its memory (including any open programs and documents). The computer is on, but almost completely inactive.

You should put the computer to sleep to conserve power when you take a work break.

To put the PowerBook to sleep

- If the computer is on, choose the Sleep command from the Special menu.



- If the computer is off, you need to turn it on before you can put it to sleep.

Automatic sleep

If you don't use the computer for several minutes, it goes to sleep automatically. This conserves battery power. You will notice that if you spend several minutes reading without using the computer, or if you take a break, the screen may be dark when you're ready to resume working.

To wake the computer, press any key on the keyboard (except Caps Lock). The desktop reappears looking just the way it did before the computer went to sleep.

On

When the PowerBook is on, you can do your work.

To turn the PowerBook on

- If the computer is off, press the power button (marked with the icon ) .

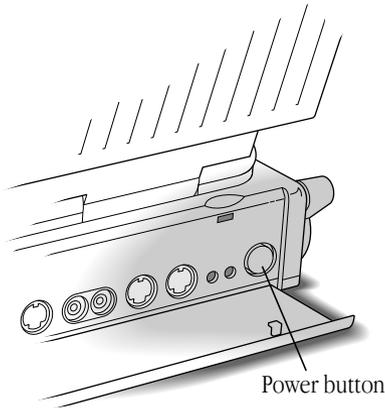

- If the computer is in sleep, press any key on the keyboard (except Caps Lock).

On/off summary

If the power state is	And you want it to be		
	Off	Sleep	On
Off	—	—	Press power button
Sleep	Press any key to wake, and then choose Shut Down	—	Press any key except Caps Lock (pressing the power button also works)
On	Choose Shut Down	Choose Sleep	—

See the chapter on power management for more information about managing your computer's power consumption.

When you turn on your computer

When you turn on your PowerBook, the computer looks on the hard disk inside the computer for the system software it uses to start itself up. (A disk that contains the system software is called a startup disk.) When the computer finds the system software, it displays the icon shown and proceeds to start itself up.



When the startup process is complete, the Macintosh desktop appears on the screen. The desktop is a gray pattern with

- a menu bar across the top (containing the names and icons of menus)
- an icon near the upper-right corner representing the startup disk
- an icon near the lower-right corner representing the Trash



When you “wake” your computer from sleep, it does not go through the startup process because it is already on (at a reduced power level). The Macintosh desktop reappears on the screen immediately, looking just the way it did before the computer went to sleep.

Restarting a computer that's already on

You need to restart your computer—turn it off and back on again immediately—when you want to make certain changes to your control panels, use a newly installed system software file, or start up the computer from a different disk.

- **Choose Restart from the Special menu.**



When you choose Restart, the computer prompts you to save your work, closes all open programs, and restarts itself.

Choosing Restart does not affect your RAM disk (if you created one) or its contents.

You also need to restart if you see a “system error” message on the screen (indicating a temporary software problem). In this case, use the trackball to click the Restart button that appears.

Restarting a computer that can't be turned on normally

If your system crashes (a rare event resulting from temporary software problems), or if a computer with a properly installed and charged battery does not respond when you try to turn it on, you should be able to restart it using one of the methods described in this section. Try them in the order given. All these methods will cause you to lose any work you have not saved.

- **Press and release the reset button.**

You can press the button with a pen, a paper clip, or a similar object.

Restarting the computer with the reset button does not affect your RAM disk (if you created one) or its contents.

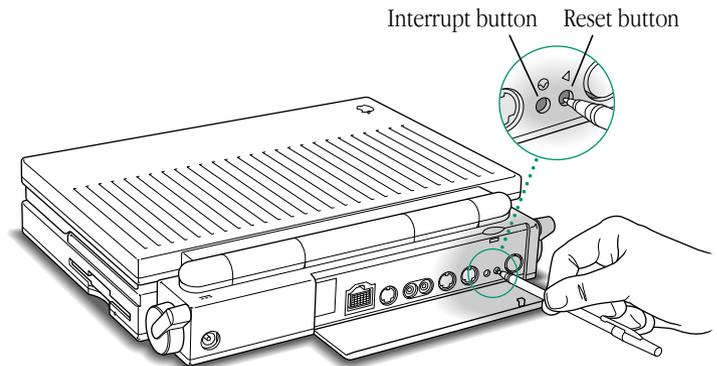

continues ►

- **Hold down the power button for 5 seconds.**

When you let go, the computer turns itself off. Turning the computer off with the power button erases the contents of a RAM disk.

- **Restart from a floppy disk.**

1. Insert the *Disk Tools* disk into the floppy disk drive.
2. Press the power button.

If the computer turns on, there may be a problem with your hard disk. You may be able to fix the problem yourself (using the Disk First Aid program or another disk repair program; see the chapter on disks in the reference section). Or you can take the computer to your authorized Apple service provider.

Learning the basics

The PowerBook comes with a tour and a tutorial to help you start using your computer as quickly as possible.

- The *Macintosh Basics* tour teaches the most basic skills you need to master before you can use your computer.
- The tutorial section of this book (Chapters 2–5) reviews the basic skills taught in the tour, and teaches a few additional skills you’ll find helpful as you become more proficient.

Take the *Macintosh Basics* tour first.

Before you begin

Make sure your computer is turned on. If the screen is dark, try the following steps in order until you see the Macintosh desktop on your screen.

1. **Adjust the screen brightness and contrast controls.**

If you see the Macintosh desktop, skip to “Finding the Tour.”

2. **Press any key on the keyboard (except Caps Lock).**

Pressing a key wakes the computer if it was in sleep (a power-conserving state described later in this chapter). If you see the Macintosh desktop, skip to “Finding the Tour.”

3. **Press the power button on the computer’s back panel.**

Pressing the power button turns the computer on if it was off. Continue with “Finding the Tour.”

Finding the tour

Your *Macintosh Basics* tour may be on a floppy disk, or it may be on the computer's hard disk.

- If the Macintosh desktop appeared on the screen when you first turned on your computer, then the system software and the *Macintosh Basics* tour were installed on your computer's hard disk at the factory. Continue with the section "Starting the Tour From the Hard Disk."
- If you needed to install system software when you set up your computer then the *Macintosh Basics* tour is on a floppy disk in the box with your computer. Locate the disk and continue with the section "Starting the Tour From a Floppy Disk."

Starting the tour from the hard disk

1. **Roll the trackball to move the arrow over the picture labeled "Macintosh HD."**

Make sure the tip of the arrow is over the picture, not over the words "Macintosh HD."

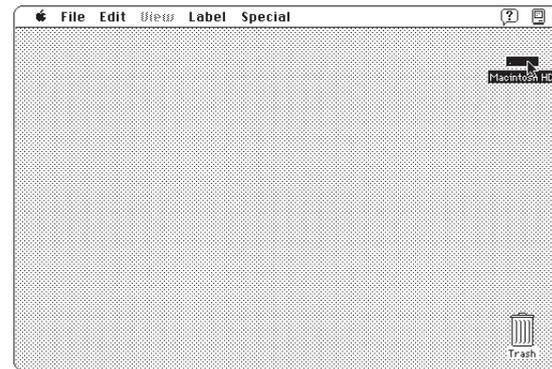

2. Being careful not to roll the trackball, press the trackball button twice in quick succession.

Now your screen should look like the picture following step 3. If it doesn't, try steps 1 and 2 again, paying special attention to the following:

- Make sure the tip of the arrow is touching the picture, not the words beneath it.
- Be sure to press the trackball button twice.
- Try pressing twice more quickly and be careful not to roll the trackball while you press.

3. Roll the trackball to move the arrow over the picture of the folder labeled “Macintosh Basics.”

Make sure the tip of the arrow is over the picture, not over the words “Macintosh Basics.”

The items in the illustration below may not exactly match those on your screen. The only item you need right now is the Macintosh Basics folder.

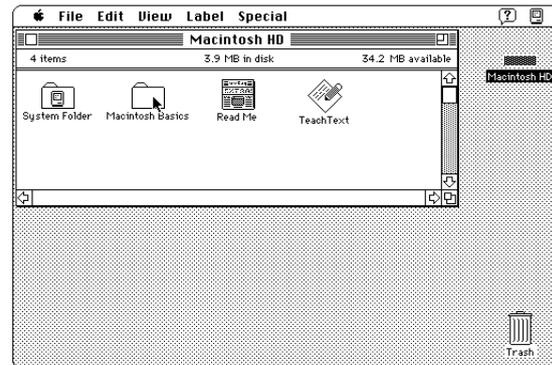

continues ►

4. **Being careful not to roll the trackball, press the trackball button twice in quick succession.**

Now your screen should look like the following illustration:

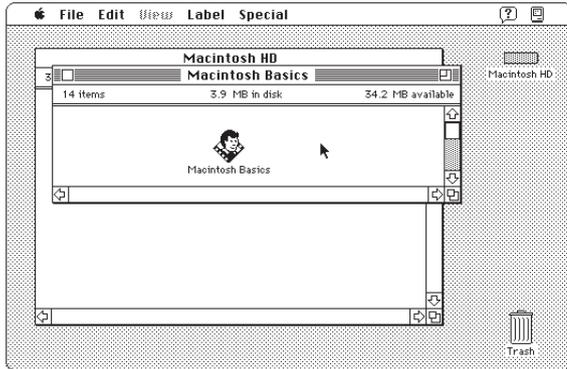

5. **Roll the trackball to move the arrow over the picture of the man labeled "Macintosh Basics."**

Make sure the tip of the arrow is over the picture of the man, not over the words "Macintosh Basics."



6. Press the trackball button twice in quick succession.

Now your screen should look like the following picture:

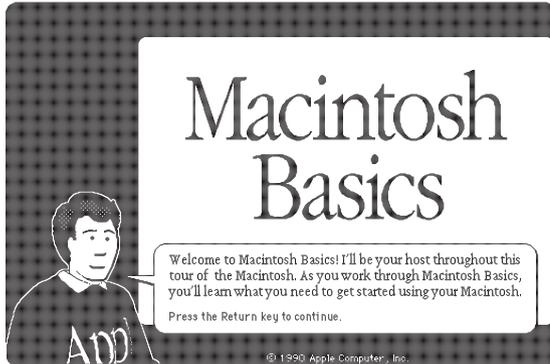

If you don't see this screen, try again, paying special attention to the following:

- Make sure the tip of the arrow is touching the picture, not the words beneath it.
- Be sure to press the trackball button twice.
- Try pressing twice more quickly and be careful not to roll the trackball while you press.

7. Follow the instructions on the screen and work through the tour.

When you finish the tour, continue with “Turning the PowerBook On and Off” and read the rest of this chapter for information that can help you use your computer safely and efficiently. Then turn to Chapter 2 and begin the tutorial.

Starting the tour from a floppy disk

1. Insert the *Macintosh Basics* disk into the floppy disk drive (metal end first, label side up).

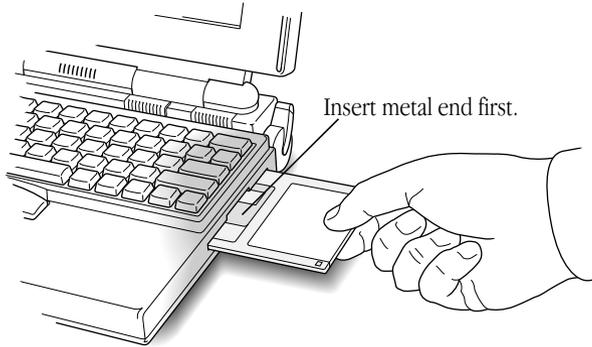

After a moment, your screen should look like this:

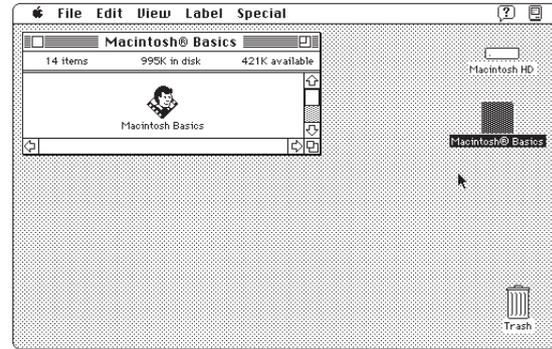

2. Roll the trackball to move the arrow over the picture of the man labeled “Macintosh Basics.”

Make sure the tip of the arrow is over the picture of the man, not over the words “Macintosh Basics.”



3. Press the trackball button twice in quick succession.

Now your screen should look like the following picture:

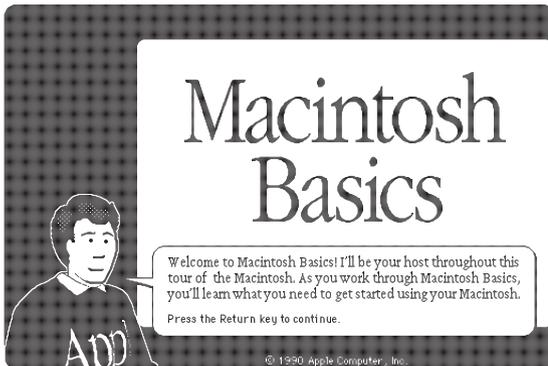

If you don't see this screen, try again, paying special attention to the following:

- Make sure the tip of the arrow is touching the picture, not the words beneath it.
- Be sure to press the trackball button twice.
- Try pressing twice more quickly and be careful not to roll the trackball while you press.

4. Follow the instructions on the screen and work through the tour.

When you finish the tour, read the rest of this chapter for information that can help you use your computer safely and efficiently. Then turn to Chapter 2 and begin the tutorial.

Important care and safety instructions

For your own safety and that of your equipment, read and follow all the instructions in this section. Keep these instructions available for reference by you and others.

Warning

- Electrical equipment may be hazardous if misused. Operation of this product, or similar products, must always be supervised by an adult. Do not allow children access to the interior of any electrical product and do not permit them to handle any cables.
- Do not use the computer in or near water.
- Do not use cables that are frayed or otherwise damaged. Hold a cable by its connector (the plug, not the cord) when connecting or disconnecting it.

- Always handle batteries carefully.
- Do not drop, puncture, disassemble, mutilate, or incinerate the battery.
- Recharge batteries only as described in this manual and only in ventilated areas.
- Transport batteries either inside the computer or in the protective case provided with each battery. Do not transport unprotected batteries.
- Do not short-circuit the battery terminals (that is, do not allow a metal object such as a paper clip or key chain to touch the terminals). Doing so may cause an explosion or a fire.

▲ Caution

- If you have a problem with your computer and nothing presented in the manuals that came with the computer solves the problem, take the computer to your authorized Apple dealer or service provider. Attempting to repair the computer yourself may void the limited warranty. Contact your authorized Apple dealer or service provider for additional information about this or any other warranty question.
 - Do not attempt to open the computer's case. There are no user-serviceable parts inside. Take the computer to an authorized Apple service provider if necessary.
 - Do not drop or jar the computer.
-
- Do not move the computer when you can hear its hard disk spinning. When you put the computer to sleep, wait until the screen is blank before moving the computer.
 - Use only the power adapter supplied with your computer. Adapters designed for other electronic devices may look similar, but they may not work with your equipment and may damage the computer.
 - Never force a connector into a port. Make sure that the connector matches the port and that it's right side up. If the connector and port do not join easily, they do not match.

- Do not use the computer in wet or dusty environments.
- Keep dirt and liquids away from the ports on the back panel, the keyboard, and the trackball. If you spill any food or liquid onto the computer, shut it down immediately and unplug it before cleaning up the spill. Depending on what you spilled and how much got into the computer, you may have to bring the computer to an authorized Apple service provider for cleaning.
- Do not touch the screen with any sharp or pointed objects.
- Use only the battery supplied with your computer. Batteries designed for other portable computers may look similar, but they may not work with your computer and may damage it.
- When recharging the battery, use only the power adapter supplied with your computer. Adapters designed for other electronic devices may not work with your equipment and may damage the computer or the recharger.
- Do not leave batteries in hot locations (such as the trunk of a car).

△ Important

- If the computer has been in a cold place for several hours, let it warm up to room temperature before you use it.
- Use the computer only in environments where the temperature range is between 50°F/10°C and 104°F/40°C.
- Do not expose the computer to very low (less than –13°F/–25°C) or very high (more than 140°F/60°C) temperatures.
- If necessary, clean the outside surfaces of your computer equipment with a damp (not wet) cloth or paper towel.
- Clean the screen with soft, lint-free paper or cloth and a mild glass cleaner. Do not spray the glass cleaner (or any other liquid) directly onto the screen.

Health concerns associated with computer use

Muscle soreness, eye fatigue, and other discomforts and injuries sometimes associated with computer use can result from performing any number of activities. Misuse of the same muscles during multiple activities can create a problem that might not otherwise exist. For example, if you engage in nonwork activities that involve repetitive stress on the wrist—such as bicycling—and also use your computer’s keyboard improperly, you may increase your likelihood of developing wrist problems. Preventing health problems requires careful attention to the way you use your body at all times.

The most common health effects associated with using a computer are musculoskeletal discomfort and eye fatigue. Any activity that involves sitting for long periods of time, including using a computer, can make your muscles sore and stiff.

To prevent discomfort and fatigue:

- Arrange your work space so the furniture is properly adjusted for you and doesn’t contribute to an awkward, inappropriate working posture.
- Take frequent short breaks to give your muscles and eyes a chance to rest and refresh.

Repetitive stress injuries

Repetitive stress injuries (RSIs) can occur when a certain muscle or tendon is repeatedly overused and forced into an unnatural position. The exact causes of RSIs are not understood, but it is thought that awkward posture, the amount of repetition, the force used in the activity, and your physiology and lifestyle may all contribute to their occurrence.

One RSI often discussed in connection with computer use is a wrist problem called carpal tunnel syndrome, which may be aggravated by improper use of computer keyboards. This nerve disorder results from excessive pressure on the median nerve as it passes through the wrist to the hand. The information on the next few pages can help you recognize hand positions that may cause discomfort.

Since the effects of repetitive movement associated with computer use can be compounded by those of other work and leisure activities to produce or aggravate physical problems, proper use of your computer system must be considered just one element of a healthy lifestyle. No one can guarantee that you won't have problems even when you follow the most expert advice on using computer equipment. You should always check with a qualified health specialist if muscle, joint, or eye problems occur.

Arranging your work space and equipment

The suggestions in this section can help you work more comfortably with your computer.

Chair

Whenever possible, use an adjustable chair that provides firm, comfortable support.

- Adjust the height of the chair so your thighs are horizontal, your feet flat on the floor, and the backs of your knees slightly higher than the seat of your chair.
- The chair should support your lower back. Follow the manufacturer's instructions for adjusting the backrest.

Keyboard and trackball

- When you use the keyboard and trackball, your shoulders should be relaxed. Your upper arm and forearm should form a right angle, with your wrist and hand in roughly a straight line.



- Use a soft touch on the keyboard and keep your hands and fingers relaxed. Avoid rolling your thumbs under your palms.

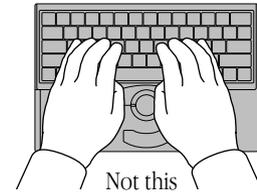

- Change hand positions often to avoid fatigue.

- If you prefer, you can adjust the angle of the keyboard by rotating the elevation feet at both ends of the back panel until they snap into position.

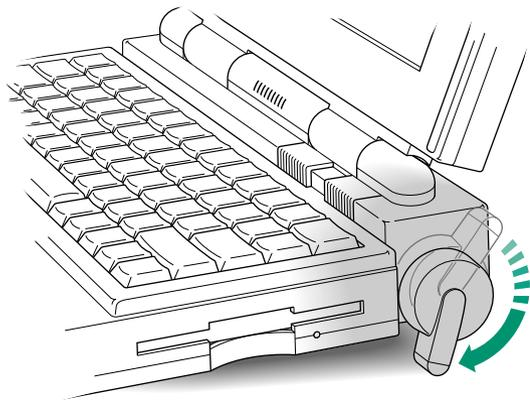

The back of the keyboard is slightly elevated when the feet are in use. Otherwise, the keyboard is level.

Mouse

If you use a mouse, position it at the same height as your keyboard. When you slide the mouse, move your entire arm. Avoid resting your arm on the desk and bending your wrist as you move the mouse.

Built-in display

- Adjust the angle of the display to minimize glare and reflections from lights and windows. Make sure there is enough light to read the screen easily.
- You may need to adjust the brightness and contrast of the screen when you take the computer from one work location to another, or if the lighting in your work area changes.

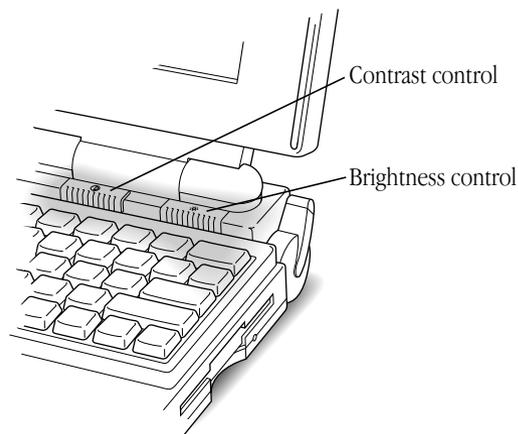

- Clean the screen regularly (see “Important Care and Safety Instructions”).

General suggestions

- Wherever you're working, take a moment to think about whether you feel comfortable, and change position if necessary.
 - Occasionally rest your eyes. From time to time focus your eyes on a distant object, and blink often while you work.
- Some computer users may develop discomfort in their arms, wrists, or hands if they do intensive work without breaks. If you begin to develop chronic pain or discomfort in your arms, wrists, or hands, consult your health specialist.

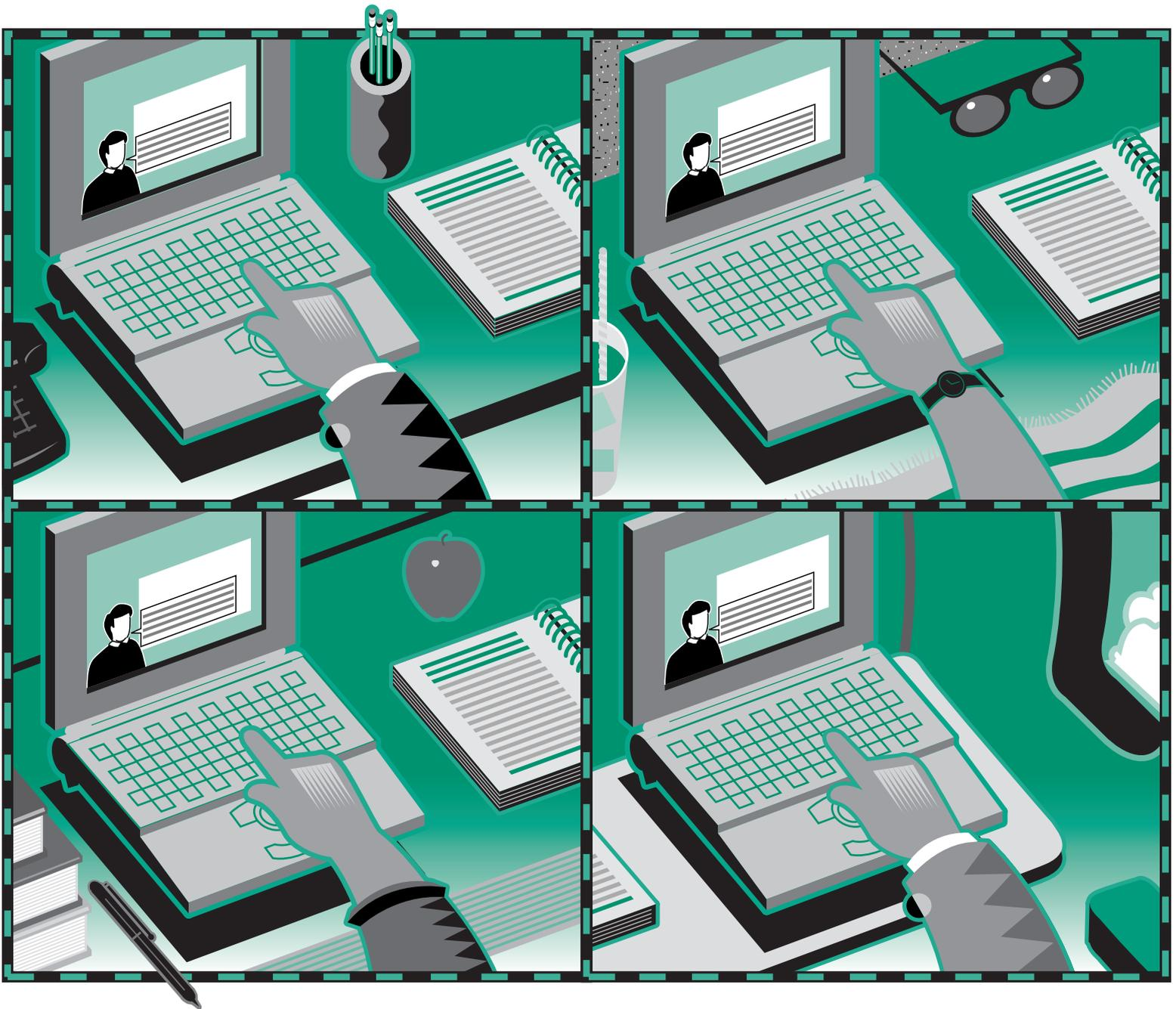

Chapter 2

Working on the Desktop

In this chapter

Review basic trackball skills:

- Moving the pointer
- Choosing a command
- Opening an icon
- Looking at the contents of a window

And learn:

- How to close a window
- How to move a window
- What the icons on your desktop represent

Before you begin

You should have already

- set up your computer according to the instructions in Chapter 1
- gone through the *Macintosh Basics* tour supplied with your computer

Make sure your computer is on.

Use the trackball

Your computer has a two-button trackball. You use the ball itself to control the movements of a pointer on the screen. The pointer you'll see most often is an arrow (↔).

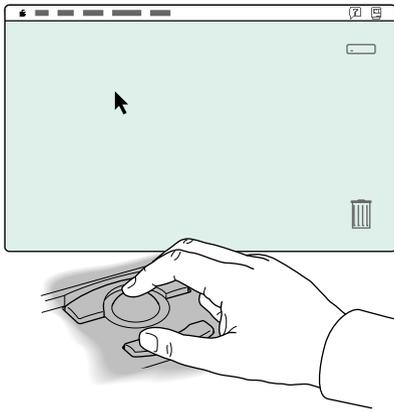

You use the buttons to initiate actions that you want the computer to perform. Both trackball buttons do the same thing. You can always use whichever one you prefer.

Much of the work you do on the Macintosh uses four trackball actions: pointing, clicking, pressing, and dragging.

(If you want to return to the *Macintosh Basics* tour for more practice with the trackball, see Chapter 1 for instructions.)

Point

You point to an object on the screen by rolling the trackball so the pointer is positioned over that object. When the pointer is an arrow, the *tip* of the arrow must be *exactly* over the object.

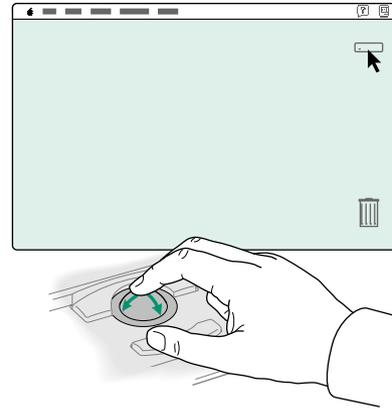

Practice pointing to different objects on the Macintosh desktop, such as the startup hard disk icon near the upper-right corner, the Trash icon near the lower-right corner, and the Help menu icon near the right end of the menu bar.



Click

You click an object on the screen by pressing and quickly releasing a trackball button while the pointer is over that object.

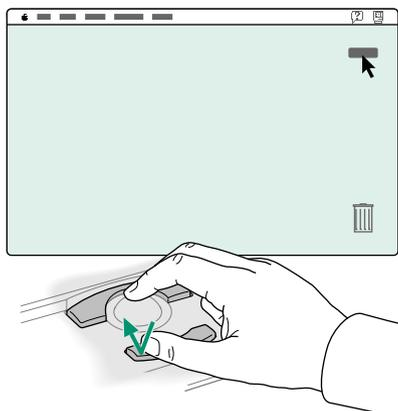

Practice clicking different objects on the Macintosh desktop, such as the startup hard disk icon near the upper-right corner and the Trash icon near the lower-right corner.

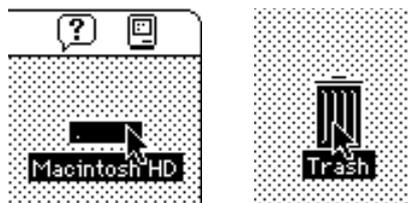

When you click an icon, it becomes *highlighted* (the icon is darkened). A highlighted icon is said to be *selected*. A selected icon is the object of whatever action you choose next.

Press

You press by holding down a trackball button without moving the trackball.

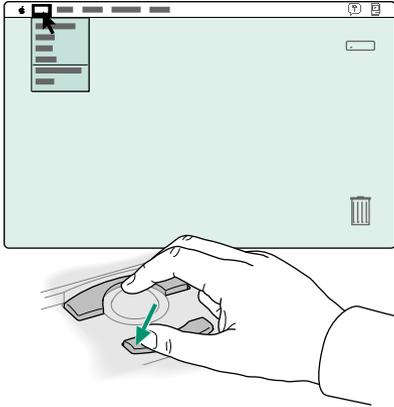

Practice pressing the menu names and icons in the menu bar—start with the Apple (🍏) menu icon at the left side, through the menu names, and across to the Help and Application menu icons at the right side. Pressing a menu name or icon “pulls down” the menu. Read the items in each menu you pull down.



Drag

You drag an object on the screen by pointing to that object and holding down a trackball button while you roll the trackball.

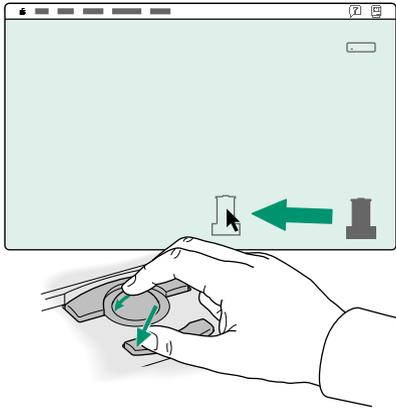

Practice dragging the startup hard disk icon and the Trash icon around the Macintosh desktop. When you drag an icon, an outline of the icon follows the pointer on the screen. When you release the trackball button, the icon itself moves.

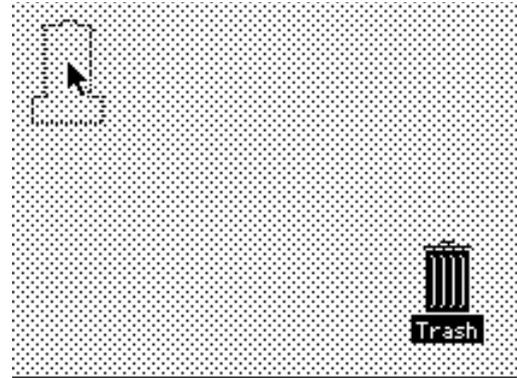

When you're finished practicing, drag the icons back to their original positions. Then click once in the middle of the desktop. (Clicking anywhere outside a selected icon returns that icon to its original "unselected" state.)

Choose a command

Choosing a command involves using a combination of the trackball actions you've reviewed.

1. **Point to the Special menu title in the menu bar.**
2. **Press to pull down the Special menu.**
3. **Drag to the first item in the menu (the Clean Up Desktop command) so it becomes highlighted, and then release the trackball button.**



When you choose Clean Up Desktop, the hard disk icon and the Trash return to their original positions (as long as they're already close).

Giving orders to your computer

Telling the Macintosh to do something involves two steps:

1. **selecting an object on the screen, and**
2. **choosing the action you want to perform on that object.**

When you select an object, you're telling the Macintosh to act upon that object.

The objects you can select include an icon on the Macintosh desktop, a sentence in a word-processing program, and a picture in a graphics program—to give just three examples.

Most of the actions you can perform on the selected object are listed in the menus at the top of the screen. The items, or actions, in the menus are called commands. When you choose a command, you are telling the computer to take the action you've chosen on the selected object.

So—you tell your Macintosh what to do by using a very simple “language” with only two kinds of words:

- nouns (the objects), and
- verbs (the actions)

and with only one rule:

- First the noun, then the verb (to this object, do that action). In Macintosh terms: select an object, then choose a command.

Open an icon

Opening an icon is your first exercise in telling the computer what you want it to do.

1. Click the startup hard disk icon to select it.

The icon is in the upper-right corner of the screen. Unless someone has changed its name, the icon is called “Macintosh HD.” Make sure that the icon is highlighted (darkened), which means that it’s selected.



2. Point to the File menu title in the menu bar.
3. Press to pull down the File menu.
4. Drag to the Open command (the second item in the File menu) so it becomes highlighted, and then release the trackball button.



When you choose the Open command, the selected icon opens into a window (in this case, the Macintosh HD window). The icon becomes filled in with a pattern of dots, indicating that it has been opened.

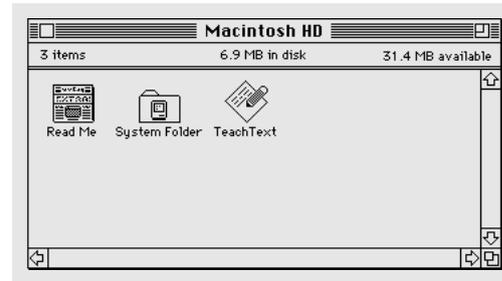

- ❖ *Different icons?* The Macintosh HD window on your screen may contain items not shown above. The differences are not important; you can still do the exercises in this chapter and the next. ❖

Look at the contents of a window

Every window has several features that help you view the window's contents. But before you can work with the contents of a window, you need to make that window the active window.

Make a window the active window

You can have several windows open on your screen at one time, but only one window can be the active window. An active window is one in which you can select objects and choose actions to perform on those objects.

The Macintosh HD window is currently on your Macintosh desktop. (The window appeared when you opened the Macintosh HD icon.) You're going to open another window now.

1. **Click the Trash icon near the lower-right corner of the screen to select it.**

Make sure that the icon is highlighted, which means that it's selected to be the object you'll act upon next.



2. **Point to the File menu title in the menu bar.**
3. **Press to pull down the File menu.**

4. Drag to the Open command so it becomes highlighted, and then release the trackball button.



When you choose the Open command, the Trash icon opens into a window (the Trash window). The Trash icon becomes filled in with a pattern of dots, indicating that it has been opened.

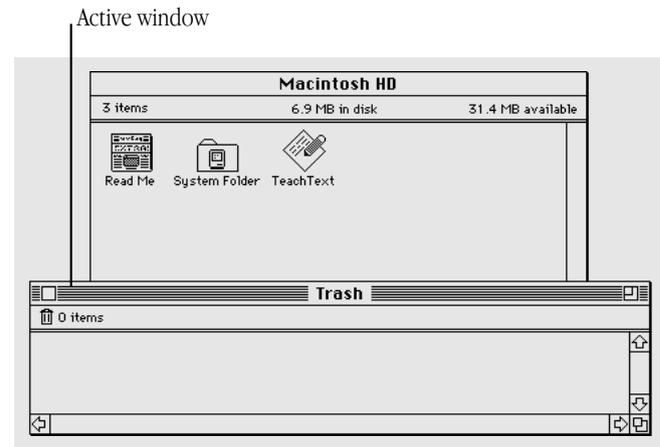

You should now have two windows on your Macintosh desktop: the Macintosh HD window and the Trash window. The Trash window is the active window. An active window has a series of solid lines at the top of the window.

continues ►

5. Click anywhere in the Macintosh HD window to make it the active window.

Notice that the solid lines now appear at the top of the Macintosh HD window. (The area containing the window title and the solid lines is called the title bar.) When windows overlap, the active window is the one that's on top.

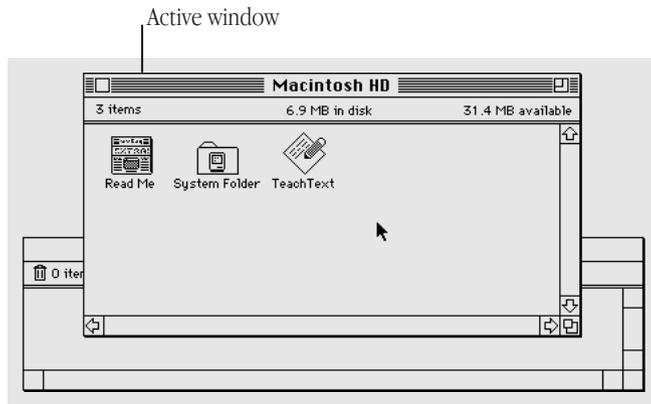

Make a window larger or smaller

Sometimes you want to make a window larger, so you can see more of its contents, or smaller, so it takes up less space on your screen. You can change a window's size by dragging its size box or by clicking its zoom box.

1. Point to the size box in the lower-right corner of the (active) Macintosh HD window.

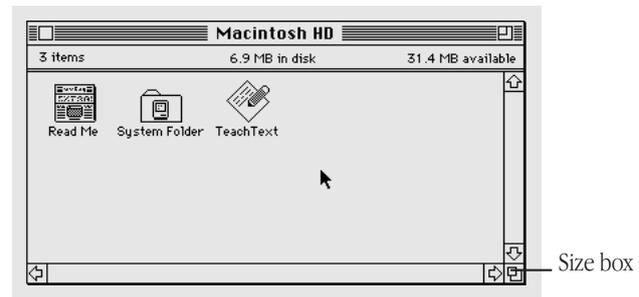

2. Drag the size box in any direction, and then release the trackball button.

While you drag, an outline follows the pointer to indicate the window's new size. The new size takes effect when you release the trackball button.

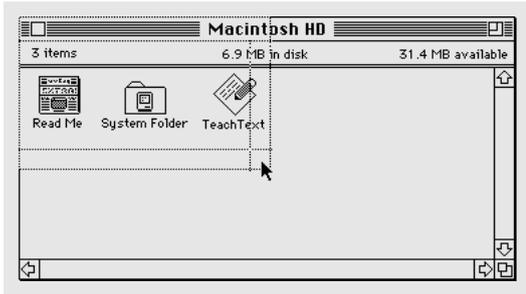

3. Click the zoom box near the right end of the title bar.

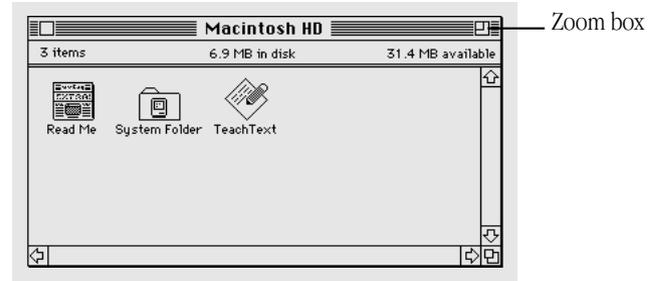

The window “zooms” to a size that shows all the items in the window.

4. Click the zoom box again.

The window zooms back to its previous size (the size that you chose in step 2).

Move the hidden contents of a window into view

As you work with your computer, you'll encounter windows containing more than you can view on the screen at one time. You can view contents that are out of sight, as described in the following steps.

1. **Check that the Macintosh HD window is active, then click the System Folder to select it.**



Make sure that the icon is highlighted, which means that it's selected.

2. **Point to the File menu title in the menu bar.**
3. **Press to pull down the File menu.**
4. **Drag to the Open command so it becomes highlighted, and then release the trackball button.**

When you choose the Open command, the System Folder icon opens into a window (the System Folder window).

You should now have three windows on your Macintosh desktop: the Macintosh HD window, the Trash window, and the System Folder window. (One or more of these windows may be covered by the others.) The System Folder window is the active window because you opened the System Folder most recently.

5. **Point to the size box in the lower-right corner of the System Folder window.**

6. Drag the size box diagonally (up and to the left) to make the window about half its current size, and then release the trackball button.

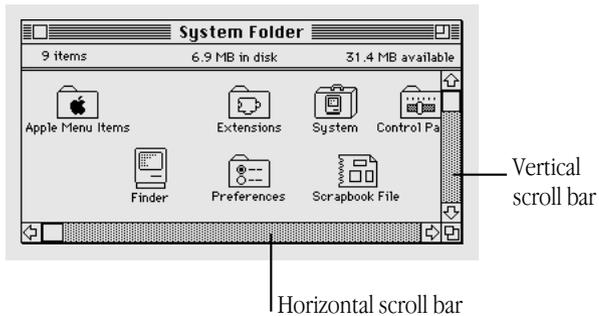
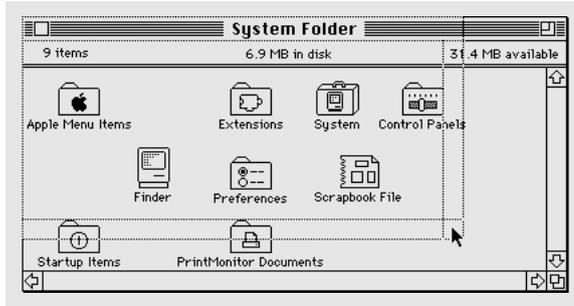

The bars across the bottom and along the right side of the System Folder window should now be gray, indicating that the window has contents that are not currently visible. The gray bars are called scroll bars.

7. Press the scroll arrow at the right end of the horizontal scroll bar.

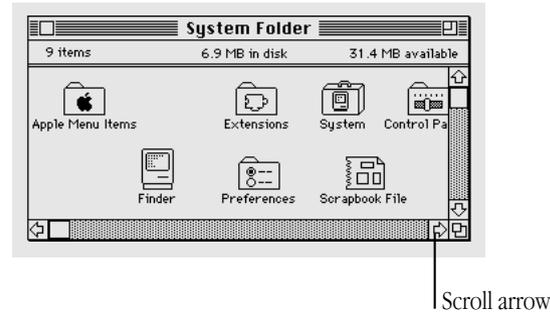

The contents of the window scroll past, bringing into view the icons that were out of sight on the right.

8. Press the scroll arrow at the left end of the horizontal scroll bar.

The contents of the window scroll past, bringing back into view the icons that were out of sight on the left.

continues ►

9. Drag the scroll box toward the middle of the horizontal scroll bar, and then release the trackball button.



Now you see the icons near the middle of the window.

The vertical scroll bar, scroll box, and scroll arrows work the same way. Try them.

Close a window

When you no longer need to see the contents of a window, you can close it by clicking the *close box*.

1. In the (active) System Folder window, point to the close box near the left end of the title bar.

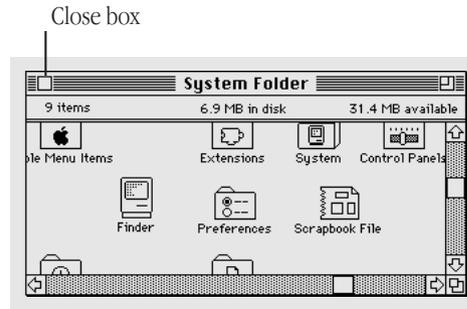

2. Click the close box.

The window closes, and the System Folder icon no longer has a pattern of dots in it.

There are now two windows on the desktop: the Macintosh HD window and the Trash window. (One may be hidden by the other.)

Move a window

You can move a window anywhere on the screen by dragging its title bar. By changing the position and size of windows, you can arrange your Macintosh desktop in whatever way is best for you.

1. Point to the title bar of the (active) Macintosh HD window.

Position the pointer anywhere on the title bar except over the close box or the zoom box.

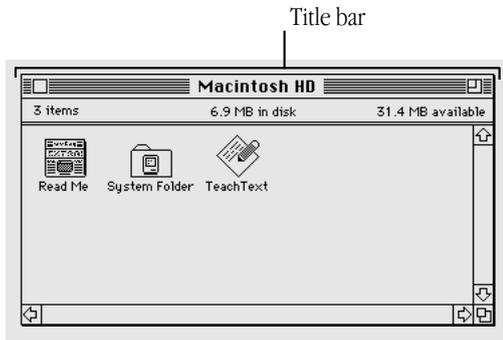

2. Drag in any direction, and then release the trackball button.

When you drag, an outline of the window follows the pointer on the screen. When you release the trackball button, the window moves to the position you've chosen.

Notice how the Macintosh HD window, because it is the active window, stays on top of the Trash window if and when the two windows overlap.

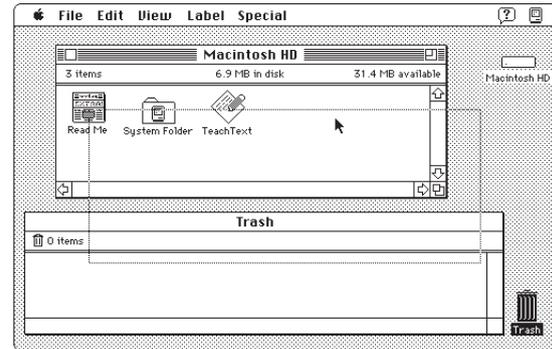

3. Close the Macintosh HD window by clicking the close box near the left end of the window's title bar.

If you can't see the close box, drag the window until you can.



continues ►

The window closes, and the Macintosh HD icon reappears in its previous form.

The Trash window (the remaining window on the Macintosh desktop) becomes the active window.

4. Close the Trash window by choosing Close Window from the File menu.



You choose Close Window by pointing to the File menu title, pressing to pull down the menu, dragging to the Close Window command, and, with the command highlighted, releasing the trackball button.

Of course, you can also close the window by clicking its close box.

What's on the desktop?

Just as a desk's large flat surface is its work space, the Macintosh "desktop" is the work space on your computer. The desktop metaphor gives you a familiar way of thinking about how to use the Macintosh.

Aside from the field of gray that represents the "surface" of your work space, the Macintosh desktop has icons, windows, and menus.

- Icons represent containers.
- Windows let you view what's inside the containers.
- Menu list actions that you can apply to selected containers or their contents.

Icons represent containers

Icons can contain other icons, or they can contain information.

For example, the startup hard disk icon contains the System Folder icon. The System Folder icon contains the programs (also represented by icons) that in turn contain the information the Macintosh needs to start itself up and work properly.

Different types of icons represent different types of containers.

Hard disks and floppy disks are like filing cabinets. You use disks to store files—your programs and the documents you create with them.



Hard Disk



Floppy Disk

Shared disks are like filing cabinets containing office supplies or information that you share with others in your work group. Your Macintosh needs to be connected to a network before you can use shared disks.



NetMart



Shared Disk

Folders are like folders in a file drawer. You use folders to organize your files.



System Folder



Mailing Lists

Programs are files containing instructions to the computer that let you do certain types of work.



TeachText



SketchPad



MemoMaker



BeanCounter

Documents are files containing words, pictures, numbers, sounds—whatever you create with your programs.



Taiko Report



Sketch



Office Design



Concert Memo



Budget



Studio Layout

The Trash is a container for files that you no longer want.



Trash

Windows let you see what's inside containers

Windows let you see what's inside all these containers. When you open a disk icon, the window that appears shows you what's on the disk. When you open the document icon representing a memo, the window that appears shows you the memo.

Changing the size of a window or viewing its contents does *not* change the contents. The contents remain the same; only your view changes.

Menus offer you choices

Like the menus in a restaurant, Macintosh menus let you choose. You choose among different actions that the computer can perform on containers (icons), or on their contents (such as words in a memo).

Using the keyboard

You use the keyboard to type text and numbers, just as you would on a typewriter. (For touch typists, your keyboard has raised dots in the middle of the D key and the K key to help position your fingers on the home row.)

Depending on the program you're using, you can use special keys on the keyboard to give commands to the computer and to modify certain things that you do with the trackball. Macintosh PowerBook computer keyboards have two types of special keys: modifier keys and arrow keys.

Modifier keys

All Macintosh keyboards have four modifier keys: Shift, ⌘ (Command), Option, and Control.

Pressed by itself, a modifier key does nothing. You need to press it in combination with another key (or while using the trackball). The modifier key causes the other key or trackball to give a different ("modified") result.

You type a capital letter, for example, by pressing the Shift key with a letter key. Most programs let you choose commands by pressing the ⌘ key with certain letter keys.

Arrow keys

All Macintosh keyboards have four arrow keys: Up Arrow, Down Arrow, Left Arrow, and Right Arrow.

Many programs let you use the arrow keys as well as the trackball to move the pointer on the screen.

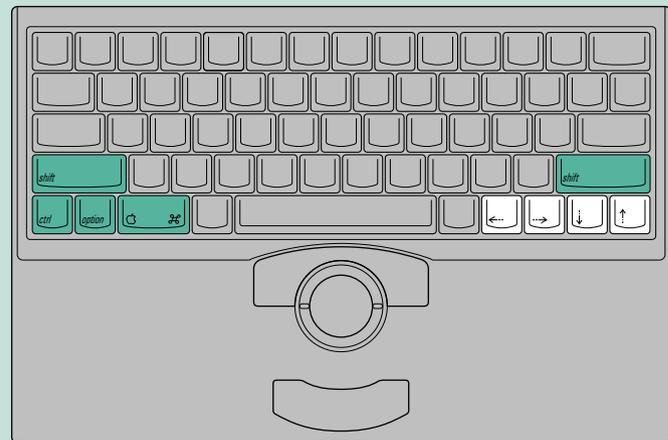

■ Modifier keys

■ Arrow keys

Chapter 3

Creating and Changing a Document

In this chapter

- How to open a program
- How to use a program to create a document
- Why it's important to save your work, and how to save it
- How to switch between programs
- How programs and system software differ from each other
- How to close a document
- How to open a document
- How to change a document

- What “keyboard shortcuts” are and how to use them
- How to quit a program
- How to make a copy of a document
- How to change the name of a document
- How to use the Trash

Before you begin

Make sure that your computer is on.

Open a program

Your computer comes with a simple word-processing program called TeachText. You're going to use this program to create a document.

1. Open the Macintosh HD icon.

(Click the icon to select it, and then choose Open from the File menu.)

The Macintosh HD window appears, showing you the contents of your hard disk. The contents include the TeachText program.

2. Open the TeachText icon.

If you can't find the TeachText icon, use the scroll bars to bring it into view.



To open the icon, click the icon to select it, and then choose Open from the File menu.

When you open the TeachText program, there is one dramatic change on your desktop:

- A window called “Untitled” appears.

There are also two subtle changes:

- The menu bar shows the menu names for the TeachText program.
- The Application menu icon in the right corner of the menu bar becomes the TeachText icon.

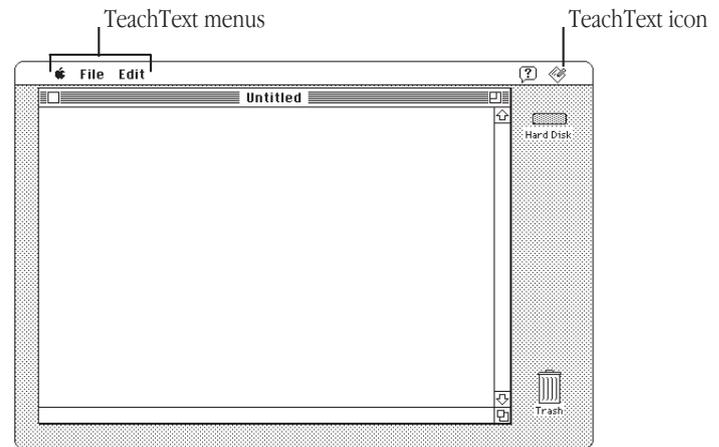

The untitled window is empty because you haven't put anything in it. In the next few sections, you're going to write a short document, save it, and give it a name.

Create a document

The untitled window is like a blank sheet of paper. In the upper-left corner of the empty document is a blinking vertical line (|). This line is called the *insertion point*, because it marks the place where the text you type will be inserted.

As you type, use your computer keyboard as you would a typewriter keyboard, except:

- If you make a mistake, press the Delete key to backspace over it.
- Don't press the Return key when you get to the end of a line. Keep typing, and words will move to the next line automatically.

Type the following text:

```
All people are born free and equal.  
Endowed with reason and conscience,  
they should act towards each other  
in a spirit of togetherness.
```

You will be changing this text later in this chapter.

Save your work

Work that you do in a program exists only in the computer's memory until you save it onto a disk. Since work that exists only in memory is lost when you shut down the computer, you need to save your work so you can come back to it later. If you don't save your work, it disappears—like thoughts that are lost unless you write them down.

1. Choose Save from the File menu.

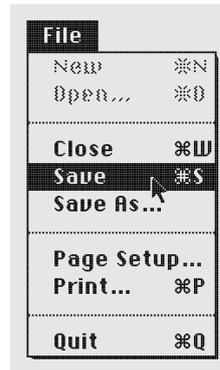

The box that appears (called a dialog box) lets you name the document and save it on your hard disk.

continues ►

2. Type “Opening Lines”.

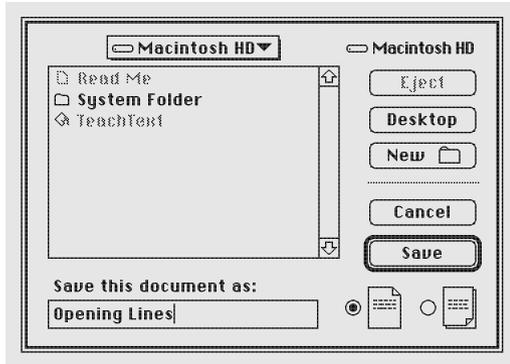

Because the word “Untitled” is selected (highlighted) when the dialog box appears, all you have to do to name your document is start typing. Whatever you type replaces the selected text.

3. Click Save.

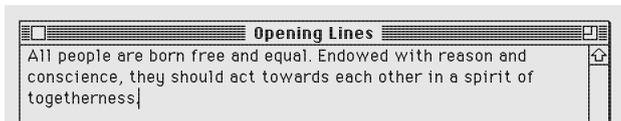

The window is now titled “Opening Lines” and the document has been stored on your hard disk.

Switch programs

You can have several programs open on your Macintosh desktop at one time (how many depends on how much memory your computer has and how much memory the programs use). But only one program at a time can be the active program. The active program is the one that’s “on top of” other open programs—in the same way that the active window is on top of other windows.

The Opening Lines window is now the active window, and TeachText is the active program. But TeachText is not the only program that’s open.

Since you turned on your computer, you’ve been working with the Finder program. The Finder displays the Macintosh desktop. The Finder is always open when your Macintosh is on, so right now it is open but not active.

1. **If the Opening Lines window covers most of your screen, make the window smaller by dragging its size box up and to the left, and then release the trackball button.**

After you resize the window, you should be able to see your hard disk icon in the upper-right corner of the desktop.

2. Make the Finder the active program by clicking the Macintosh HD icon, or clicking anywhere on the desktop outside the Opening Lines window.

The Finder becomes the active program. Notice:

- The Macintosh HD window appears on top of the Opening Lines window.
- The menu bar shows the Finder's menu titles.
- The Application menu icon at the right end of the menu bar becomes the Finder icon.

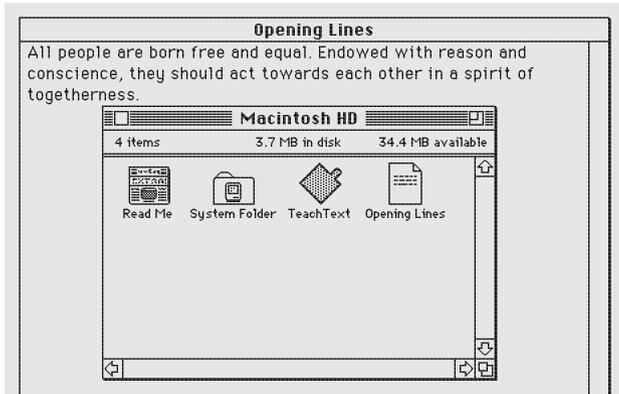

You may also notice the Opening Lines icon in the Macintosh HD window, representing the document you just created and saved.

3. Make the Opening Lines window active by clicking anywhere inside it.

(Part of the window may be hidden by the Macintosh HD window.)

When you click, the Opening Lines window comes back to the top. It's now the active window again, and TeachText is the active program.

You make a window active by clicking any visible part of it. The program that "owns" the window becomes active when the window becomes active.

Here is another way to make a program active:

4. Make the Finder the active program by choosing Finder from the Application menu at the right end of the menu bar.



continues ►

You choose Finder by pointing to the Application menu icon, pressing to pull down the menu, dragging to highlight the name Finder, and then releasing the trackball button.

The Finder becomes the active program, and the Macintosh HD window becomes the active window.

5. Make TeachText the active program by choosing TeachText from the Application menu.



TeachText becomes the active program, and the Opening Lines window becomes the active window.

All open programs are listed in the Application menu. You can use the Application menu to choose which program to make active. The icon in the menu bar is always the icon of the currently active program.

Close a document

When you close a document, you do not close the program that you used to create it. (Closing a program is called quitting.) The program remains open and active until you quit the program or make another program active.

- 1. If the Opening Lines window is not the active window, click anywhere inside it to make it active.**
- 2. Close the Opening Lines window.**

You can either click the close box near the left end of the title bar, or choose Close from the File menu.

The Opening Lines window closes but TeachText is still the active program. Notice:

- The menu bar still shows the TeachText menu titles.
- The Application menu icon at the right end of the menu bar is still the TeachText icon.

Two types of programs

Programs that you use to do your work on the computer are called *application programs*, or *applications*, because they're ways of applying computer technology to the work that you do.

Word-processing programs, for example, are applications that enable you to write memos, novels, or whatever you need to write. And if your work involves creating illustrations, designing buildings, composing music, or keeping track of large amounts of data, there are application programs for those kinds of work, too.

Because most Macintosh programs work in similar ways, you can transfer much of what you learn in one application to other applications.

Programs that the computer uses to do its work (in contrast to your work) are called *system software*, or sometimes the *operating system*.

Between you and the system software is a program called the *Finder*, which displays the Macintosh desktop. It's called the Finder because, like the viewfinder in a camera, it gives you a view of all the objects— disks, programs, folders, and documents—on your desktop.

You use the Finder to tell the system software what you want it to do for you: which disks you want to use, which documents and programs you want to open, and where you want files to be stored.

Open a document

When you open a document, the program you used to create that document becomes the active program.

1. **If you closed the Macintosh HD window, open the Macintosh HD icon now.**

(Click the icon to select it, and then choose Open from the File menu.)

The Macintosh HD window appears, showing you the contents of your hard disk. The contents include the TeachText program and the TeachText document you created called Opening Lines.

The next step describes a different way to open an icon.

continues ►

2. Open the Opening Lines icon by double-clicking it.



To double-click an icon, you click it twice in rapid succession without moving the pointer. (Use the trackball to position the pointer over the icon, and then click one of the trackball buttons twice.) Double-clicking an icon has the same effect as selecting the icon and then choosing the Open command.

When you open Opening Lines, TeachText becomes the active program. Notice that:

- the Opening Lines window appears
- the menu bar shows the TeachText menu titles
- the Application icon at the right end of the menu bar is the TeachText icon

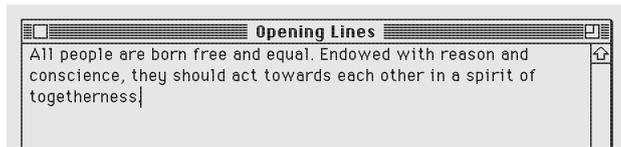

Change a document

The Opening Lines window shows you the text you typed. In this section you'll make some changes to the text using techniques that work in most Macintosh programs.

Keep two things in mind:

- The insertion point—the blinking vertical line—marks the place where text will appear.
- A pointer called an I-beam (it looks like this: I) replaces the arrow pointer (\blacktriangleright) when you're working with text. You control the I-beam pointer with the trackball in the same way that you control the arrow pointer.

1. **Locate the insertion point. It should be in the upper-left corner of the document.**
2. **Locate the I-beam pointer (I). If you don't see it, roll the trackball slightly. The pointer moves as the trackball moves.**

Now you're ready to change the text.

3. Move the I-beam pointer to the immediate left of the word “people” (after “All”).
4. Drag horizontally, selecting the word “people”, and then release the trackball button.

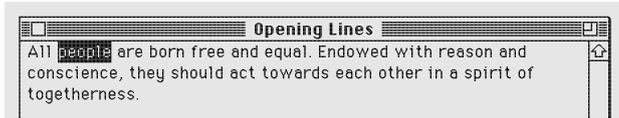

To drag, hold the trackball button down while you roll the trackball. The selected word is highlighted (surrounded by black).

If you select more or less than you intended to, go back to step 3 and try again.

5. With “people” selected, type the words “human beings”.

The words you type replace the word you selected. (Press the Delete key to backspace over any typing errors.)

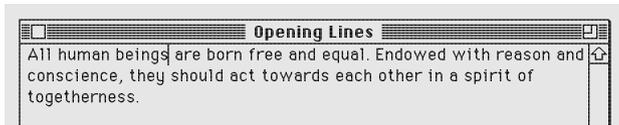

6. Move the I-beam pointer between the word “equal” and the period (to the immediate left of the period).

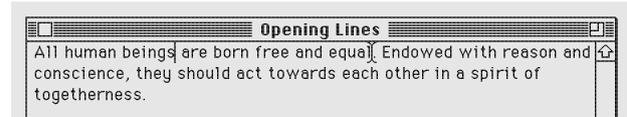

7. Click the trackball button once.

Clicking moves the insertion point to the spot where you positioned the I-beam. Whatever you type next is inserted at that point.

8. Press the space bar once, and then type the words “in dignity and rights”.

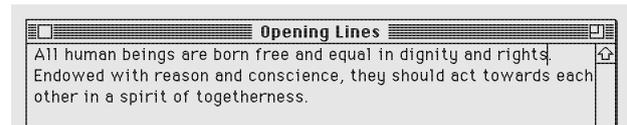

continues ►

Now you'll rearrange some text.

9. Move the I-beam pointer to the immediate left of the word "they" (after "conscience,").
10. Drag horizontally, selecting the word "they", and then release the trackball button.

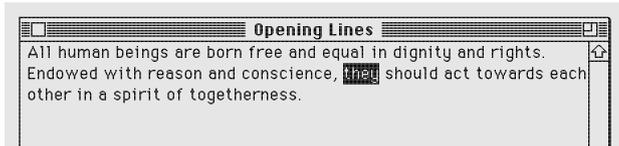

11. With "they" selected, choose Cut from the Edit menu.

Choosing Cut removes the selected material from the document and stores it in a temporary file called the Clipboard.

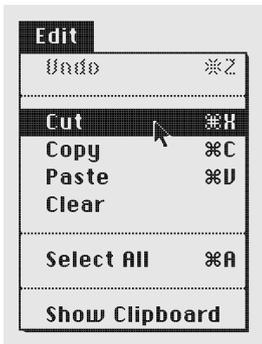

12. Move the I-beam pointer to the immediate left of the word "Endowed".

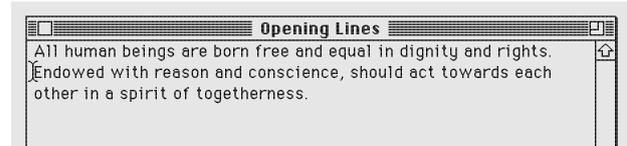

13. Click to place the insertion point.

14. Choose Paste from the Edit menu.



When you choose Paste, your computer takes whatever's in the Clipboard and puts it into the document at the location of the insertion point.

15. Press the space bar once, type “are”, and then press the space bar once again.

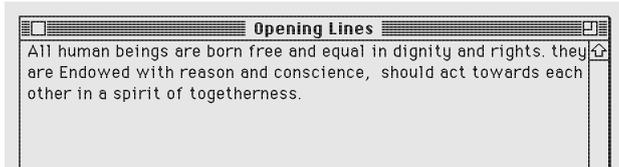

16. Move the I-beam pointer between the letters *t* and *b* in the word “they”.

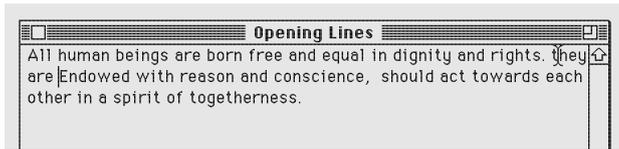

17. Click the trackball button to place the insertion point.
18. Press the Delete key once and then type a capital *T*.

Save your work so far

The changes you’ve made so far are not part of Opening Lines until you save them. You save them by telling the computer to record them in the Opening Lines document that’s stored on your hard disk.

It’s important to remember that no change is “official” until you save it onto a disk. Your work could be lost if power to the computer were interrupted or if a problem caused the computer to stop working properly.

Choose Save from the File menu.

Save regularly, and save often.

Taking a shortcut

You can choose some menu commands by using the keyboard instead of the trackball. A *keyboard shortcut* is a combination of keys that you press at the same time to get the same result as choosing a command from a menu. One of the keys you press is always the **⌘** key or another modifier key.

For example, instead of choosing Save from the File menu, you can hold down the **⌘** (Command) key on the keyboard while you press the S key. Pressing **⌘-S** is a keyboard shortcut equivalent to choosing Save from the File menu.

You can see the available keyboard shortcuts by pressing a menu title and looking at the commands in the menu. The keyboard shortcuts are listed next to the commands.

Make more changes

The changes you've made so far are now part of the document that's stored on your hard disk.

1. **Move the I-beam pointer (I) between the letters *E* and *n* in the word “Endowed”.**

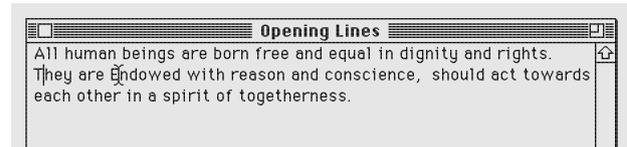

2. **Click once to place the insertion point.**
3. **Press the Delete key once and then type a lowercase *e*.**
4. **Move the I-beam pointer to the immediate right of the comma after the word “conscience”.**

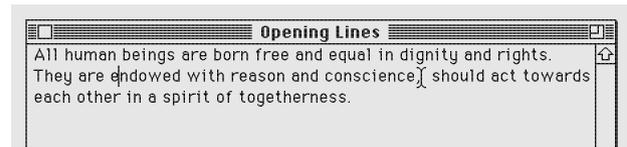

5. Press the Delete key once, press the space bar once, and then type “and”.

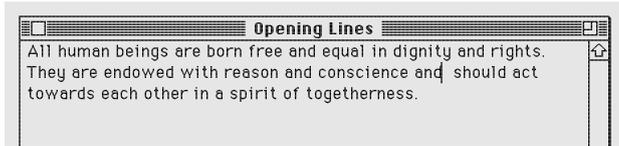

6. Move the I-beam pointer to the immediate left of “each other”.

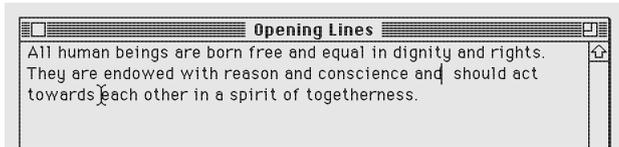

7. Click the trackball button once.

Clicking moves the insertion point to the place where you positioned the I-beam.

8. Move the I-beam pointer to the immediate right of the “each other”. Do not drag. Do not click the trackball button yet.

9. Hold down the Shift key on your keyboard and click to select the words “each other”.

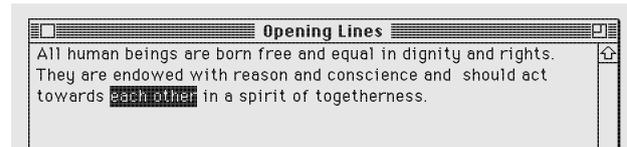

Holding down the Shift key while you click selects the text between the insertion point and wherever you click.

10. With “each other” selected, type “one another”.

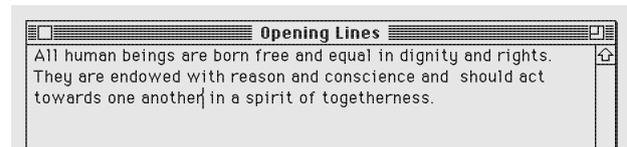

continues ►

11. Select the word “togetherness” by double-clicking it.

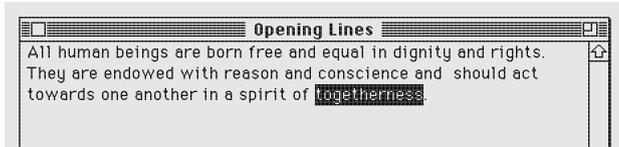

To select a word by double-clicking it, position the I-beam pointer over the word and then click twice in rapid succession, without moving the pointer.

12. With “togetherness” selected, type “brotherhood”.

You may now have extra spaces or no spaces between words. If so, position the I-beam pointer where you need to delete or add a space, click to place the insertion point, and press the Delete key or the Space bar as necessary.

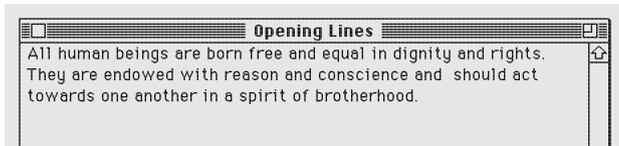

13. Choose Save from the File menu.

Quit a program

Quitting a program closes the program as well as any open documents that were created using that program. (Simply closing a document leaves the program open and active.)

1. **Make sure that the Opening Lines window is active.**
2. **Quit the TeachText program.**

You can either choose Quit from the File menu, or press the ⌘ key and the Q key together.

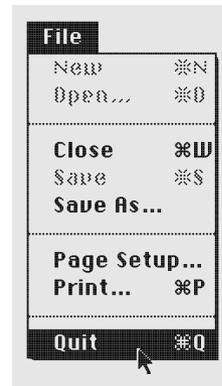

If a message asks whether you want to save any changes, click Save.

The Opening Lines document and the TeachText program are closed, and the Finder becomes the active program.

Opening and closing documents and programs

Doing this	Also causes this
Opening a document	Opens the program that created that document
Making a document window active	Makes the program that “owns” that document active
Closing a document	Simply closes that document; <i>does not</i> close the program that created that document (the program continues to use memory)
Quitting a program	Prompts you to save your work, then closes the program that created the active document (memory becomes available for other programs)

Make a copy of a document

You’ll often want to make a copy of a document so you can preserve the original and modify the copy. To practice making a copy of a document, you’ll use the “Opening Lines” document you created.

1. If you closed the Macintosh HD window, open the Macintosh HD icon now.

(Click the icon to select it, and then choose Open from the File menu.)

The Macintosh HD window appears, showing you the contents of your hard disk. The contents include the TeachText program and the TeachText document you created called Opening Lines.

2. Click the Opening Lines icon to select it.



continues ►

3. Choose Duplicate from the File menu.

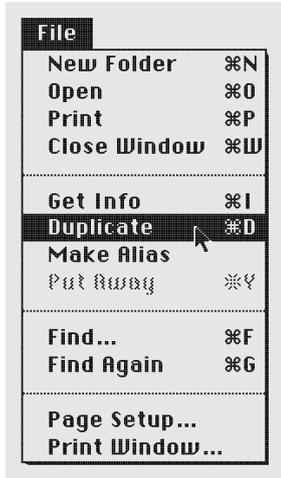

A new icon, labeled “Opening Lines copy”, appears in the hard disk window. Notice that the icon is selected.



Other ways to make a copy of a file are outlined in the summary chapter in the reference section of this book.

Change the name of an icon

You can change the name of any icon, using any characters except a colon (:). If you change an icon’s name and then open it, you’ll see that the name of its window has also changed.

1. Drag the “Opening Lines copy” icon away from the original icon so that the two icons do not overlap.
2. Click the name (not the icon) “Opening Lines copy.” Do this even if the icon is already selected.

When the name is selected, it is highlighted and a box appears around it. Notice that when you point to the selected name, the arrow pointer becomes an I-beam.

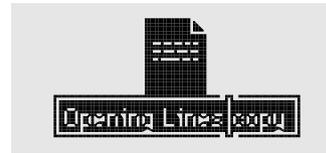

3. With the name selected, type “Article 1”.

Whatever you type replaces the selected text.

4. Press the Return key.

Pressing Return saves the new name.

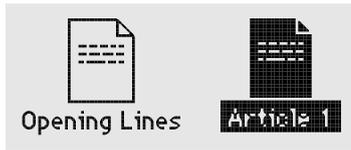

Now you have two identical documents with different names. You can revise one without changing the other.

Use the Trash

When you no longer need a file or a folder, you can throw it away by dragging its icon to the Trash. Practice using the Trash by throwing away the “Article 1” document, which you created when you made a copy of the “Opening Lines” document.

1. If you closed the Macintosh HD window, open the Macintosh HD icon now.

(Click the icon to select it, and then choose Open from the File menu.)

The Macintosh HD window appears, showing you the contents of your hard disk. The contents include the TeachText program and two documents, one called Opening Lines and the other called Article 1 (you may have to use the window’s scroll bars to see them).

continues ►

2. Drag the Article 1 icon to the Trash icon until both icons are highlighted, and then release the trackball button.

If the Macintosh HD window is blocking the Trash icon, move the window by dragging its title bar.

Both icons are highlighted when the tip of the arrow pointer reaches the Trash icon.

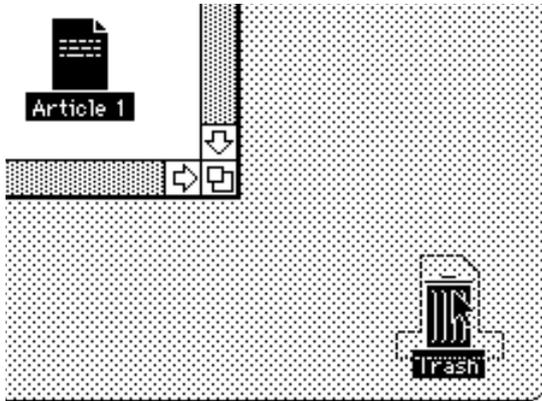

When you release the trackball button, the Article 1 icon “disappears” into the Trash. When you put an object in the Trash, the Trash icon bulges to indicate that it is no longer empty.

3. Open the Trash icon.

(Click to select the icon, and then choose Open from the File menu, or click the Trash twice in quick succession.)

The Trash window appears. Anything you drag to the Trash stays there until you empty the Trash.

You can retrieve items from the Trash by clicking to select them and then choosing Put Away from the File menu. (Or you can drag the items back to where they were.)

4. Choose Empty Trash from the Special menu.

A message appears asking you to confirm that you want to permanently remove the contents of the Trash.

5. Click OK.

Clicking OK empties the Trash—in other words, its contents are erased from the disk.

Notice that the Trash icon no longer bulges, indicating that it is empty.

6. Close the Trash window by clicking its close box.

Chapter 4

Working With Disks

In this chapter

- What hard disks and floppy disks are for, and how they differ
- How to insert and remove a floppy disk
- How to prepare a disk for use
- How to copy the contents of a disk
- How to protect a floppy disk and its contents
- How to put programs onto your computer

Before you begin

You need a new floppy disk to follow the steps in this chapter. You should be able to get floppy disks from wherever you got your computer.

Make sure that your computer is on.

Insert a floppy disk

Your computer's floppy disk drive can accommodate 3.5-inch (89-millimeter) floppy disks of two types:

- high-density disks, which can hold up to 1.4 megabytes (MB) of information
- double-sided disks, which can hold up to 800 kilobytes (K) of information

(The next page explains kilobytes and megabytes.)

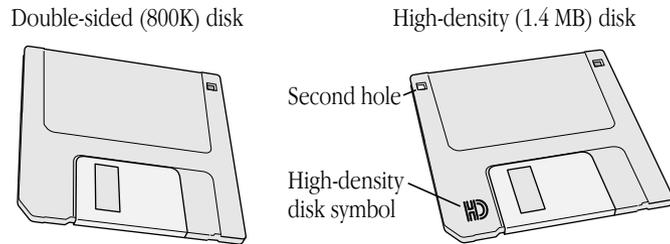

Follow these steps to insert your new disk into the disk drive.

1. **Write “Practice” on a blank disk label.**
2. **Attach the label to your new floppy disk.**
The molding of the disk's plastic case indicates where the label goes. Do not affix the label over the metal shutter.
3. **Hold the disk with your thumb on the label and the metal shutter pointing away from you.**
4. **Push the disk into the floppy disk drive, label side up and metal shutter first.**

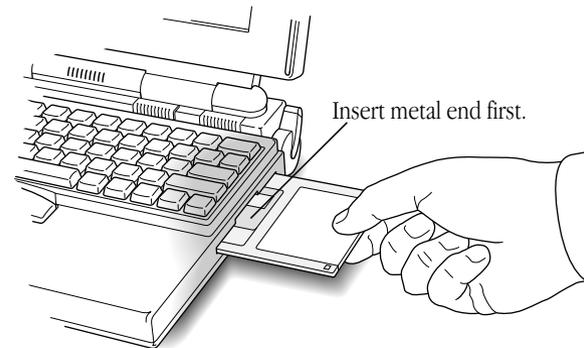

The next section, “Initialize a Disk,” explains what to do about the message that appears on your screen.

Floppy disks and hard disks

Both floppy disks and hard disks function like filing cabinets: you use them to store information. You can store much more on a hard disk than on a floppy disk, however, and the computer can retrieve information from a hard disk much faster.

Floppy disks and hard disks are represented by different icons.

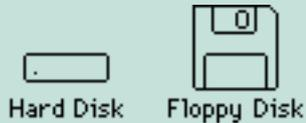

The disk whose icon is closest to the upper-right corner of your desktop is the *startup disk*, which contains the information the Macintosh uses to operate.

Your hard disk is sealed into the hard disk drive inside your computer. Floppy disks, in contrast, can be taken in and out of floppy disk drives so you can easily transfer information from one computer to another.

A floppy disk is made of thin, flexible material with a magnetic coating. To protect it and make it easier to handle, the floppy disk itself is enclosed in a rigid plastic case, which gives the floppy disk its “non-floppy” character. Floppy disks are sometimes called *diskettes*.

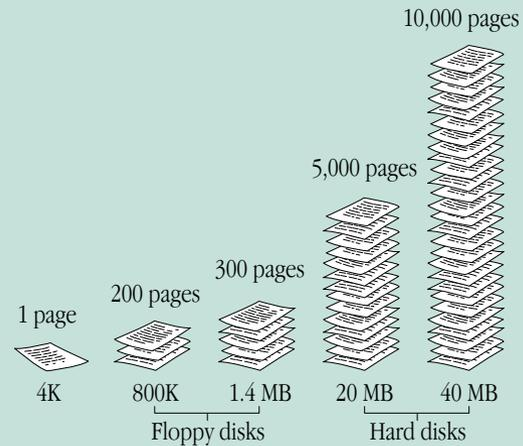

Even the smallest hard disks can hold the equivalent of a few thousand pages of information. High-density floppy disks can hold 1.4 megabytes (MB) of information—about 300 typewritten pages. Double-sided floppy disks can hold 800 kilobytes (K) of information—about 200 typewritten pages. (A megabyte is about 1,000 kilobytes.)

Initialize a disk

Every new disk needs to be prepared for use. Preparing a new disk is called initializing it. In the same way that lines are drawn on a newly paved parking lot to mark off parking spaces, the initializing process creates organized areas on the disk where the computer can store information. Your computer's hard disk was initialized at the factory, but you need to initialize any new floppy disks you want to use.

1. Read the message on your screen.

The computer requests information from you or warns you about the consequences of an action by presenting a message in the form of a dialog box.

If you inserted a high-density disk, this dialog box appears:



If you inserted a double-sided disk, this dialog box appears:



2. If you inserted a high-density disk, click **Initialize**.
If you inserted a double-sided disk, click **Two-Sided**.

Another dialog box appears:



This dialog box appears because you can initialize old disks as well as new ones—and the computer doesn't know whether the disk in the drive is old or new. Initializing erases all information on a disk. In this case, because the floppy disk is new, there is no information on it to erase.

3. Click Erase.

A third dialog box appears:



4. Type "Practice".

If you make any typing errors, press the Delete key to backspace over them.

5. Click OK.

The computer takes about a minute to initialize the disk. Messages appear on the screen to let you know how the process is going.

When initialization is finished, the disk's icon appears directly below the Macintosh HD icon (the startup hard disk icon) near the upper-right corner of the desktop.

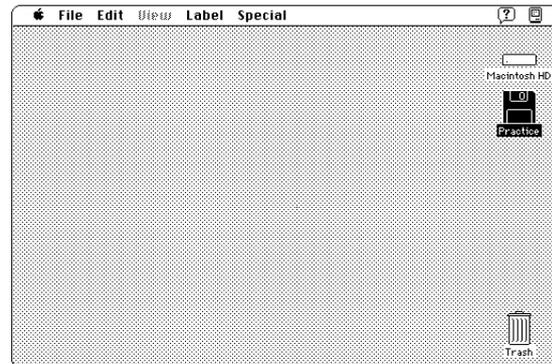

Copy the contents of a disk

Most programs you'll use with your Macintosh are supplied on floppy disks. You can use a program more efficiently if you first install it on your hard disk. You install most programs by copying them from the floppy disk to your hard disk.

To practice copying the contents of a floppy disk to your hard disk, use your practice disk (even though there's nothing on it).

1. Drag the Practice floppy disk icon to the Macintosh HD icon until both icons are highlighted, and then release the trackball button.

Both icons are highlighted when the tip of the arrow pointer reaches the Macintosh HD icon.

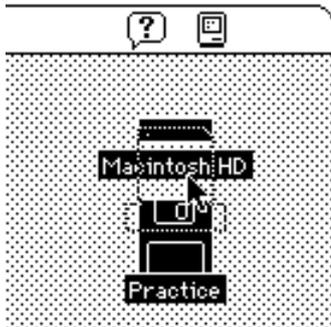

When you release the trackball button, the Macintosh copies the contents of the Practice disk onto Macintosh HD (your hard disk). Because there is nothing on the Practice disk, the copying happens very quickly.

Now, find the copy of Practice you just created.

2. Open the Macintosh HD icon.

To open the icon, click the icon to select it and then choose Open from the File menu. (You choose Open by pointing to the File menu title, pressing to pull down the menu, dragging to the Open command, and then releasing the trackball button.)

The Macintosh HD window appears, showing you the contents of the hard disk. The contents should include a new folder called Practice, which the computer created when it copied the contents of the Practice disk to Macintosh HD.

You may have to make the window larger or use the scroll bars to see the Practice folder.

3. Open the Practice folder icon.

To open the icon, click the icon to select it and then choose Open from the File menu.

The folder holds the contents of the floppy disk you've copied. In this case, the folder is empty because there's nothing on the Practice disk.

4. Close all the windows on the Macintosh desktop.

You close a window (when it's the active window) by either clicking its close box or choosing Close Window from the File menu.

Taking care of floppy disks

Follow the care instructions that came with your disks, and remember three key points:

- Keep floppy disks away from magnets. Because information is stored on the disk in the form of magnetic signals, a magnetic field can destroy that information. Televisions and monitors, telephones, loudspeakers, and certain kinds of lighting fixtures all contain magnets.
- Protect disks from extremes of temperature and humidity.
- Do not open the disk's metal shutter. Touching the disk inside the shutter could damage it.

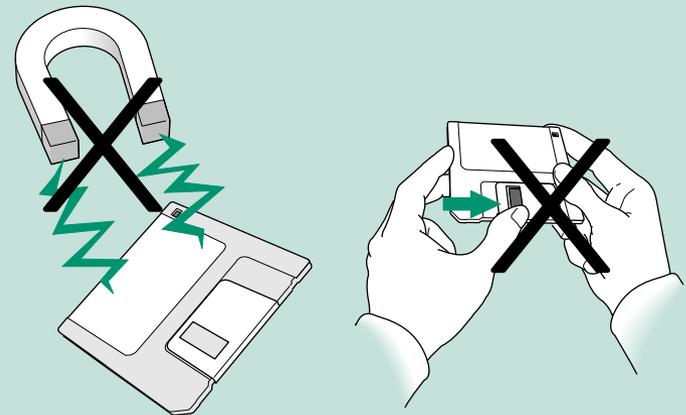

Take a floppy disk out of its drive

You take a floppy disk out of its drive when you no longer need to get information from or store information on that disk.

1. Click the Practice floppy disk icon to select it.

Click the icon, not its name.

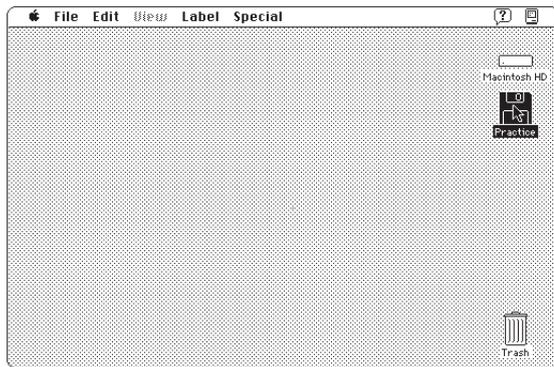

2. Eject the floppy disk by choosing Put Away from the File menu.

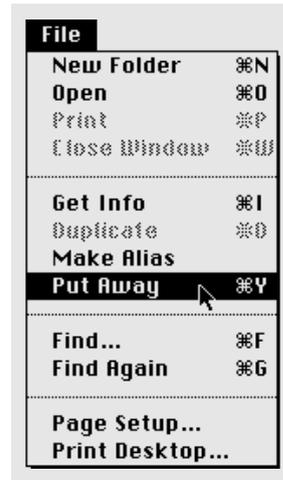

You choose Put Away by pointing to the File menu title, pressing to pull down the menu, dragging to the Put Away command, and releasing the trackball button.

Put Away returns the object you've selected to its original place. In this case, it ejects the floppy disk from the disk drive so you can put it away.

Protect the contents of a disk

You can lock a floppy disk so its contents cannot be changed in any way. When a disk is locked, you can look at the files it contains, but you cannot modify the files on it, delete them, or store any new files.

Use your practice disk to practice locking and unlocking a floppy disk.

- 1. Hold the practice disk with your thumb on the label and the metal shutter pointing away from you, as though you were going to insert the disk into a drive.**
- 2. Find the square hole in the near-left corner of the floppy disk.**

A moveable tab on the back side of the disk should be blocking the hole, indicating that the disk is unlocked.

If you're using a high-density disk, you'll notice an additional square hole, across the label from the first hole. This second hole has no tab and is always open.

- 3. Turn the disk over and lock it by sliding the tab so that the square hole is open.**

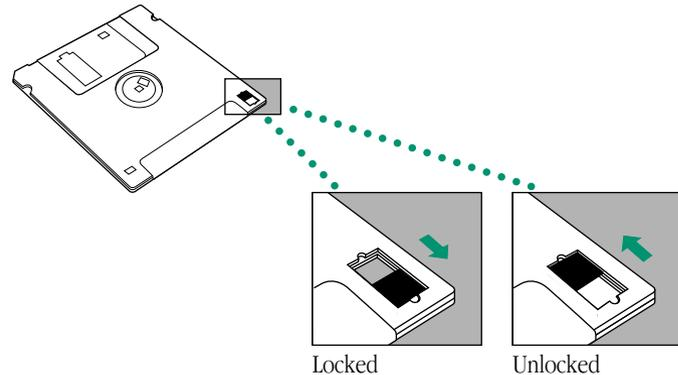

Use your thumbnail or a push pin to move the tab.

- 4. Unlock the disk by sliding the tab back so that the square hole is blocked.**

You are unlocking your practice disk now so you can use it to store files in the next chapter.

On your own: Install your programs

If you have a floppy disk drive and disks containing programs that you plan to use with your Macintosh, you can install the programs on your hard disk now (or you can wait until later and continue with the next chapter).

The general instructions in this section describe how to copy the contents of a program disk to your hard disk.

△ **Important:** Some programs need to be installed in a particular way. If your programs came with specific instructions, follow them instead of the instructions in this section. △

1. Lock the program disk.

The program disk contains your master copy of the program. Locking the disk protects its contents but doesn't keep you from copying the contents onto another disk.

2. Insert the program disk into your floppy disk drive.

3. Drag the program disk icon to the Macintosh HD icon (your hard disk icon) until both icons are highlighted, and then release the trackball button.

Both icons are highlighted when the tip of the arrow pointer reaches the Macintosh HD icon.

When you release the trackball button, messages appear on the screen to let you know that the computer is copying the contents of the program disk onto your hard disk.

When copying is finished, the contents of the program disk appear on your hard disk in a folder that has the same name as the program disk.

4. Eject the program disk by selecting it and choosing Put Away from the File menu.

5. Open the Macintosh HD icon.

The Macintosh HD window shows you the contents of your hard disk. Among its contents is the program folder, which contains the same items as the original disk.

6. Click the program folder to select it.

7. Choose Open from the File menu.

The folder window appears, showing you the contents of the program folder. The folder has the same contents as the program disk.

8. Look for a System Folder in the program folder.

Some program disks contain a System Folder so they can be used as startup disks. (A startup disk, by definition, is a disk that has a System Folder on it.) If the program disk you've copied has a System Folder, you now have two System Folders on your hard disk. For the computer to work properly, you must throw away any extra System Folders.

Throw away extra System Folders

Your startup disk must have only one System Folder on it.

Whenever you copy the contents of a program disk to your hard disk, make sure that you have not copied an extra System Folder. If you have, throw the extra System Folder away.

1. Drag the extra System Folder from the program folder to the Trash.

2. Choose Empty Trash from the Special menu.

A message alerts you that you're about to throw away the contents of the Trash (in this case, the extra System Folder).

3. Click OK to confirm that you want to throw away the contents of the Trash.

4. Close the window by clicking its close box.

Chapter 5

Learning More About Your Computer

In this chapter

- How to open the Battery desk accessory
- How to open the PowerBook control panel
- How to use the Balloon Help system
- Where to look for information about your computer and its software

Before you begin

Make sure that your computer is on.

This short chapter introduces you to the Battery desk accessory and the PowerBook control panel, with which you can monitor and control your computer's power consumption.

This chapter also tells you where to find answers to other questions you may have about your computer.

Open the Battery desk accessory

The Battery desk accessory tells you approximately how much power is left in the battery as you use the computer.

To open the Battery desk accessory:

- Choose Battery from the Apple (🍏) menu.



You can leave the Battery desk accessory open to keep track of the battery charge while you work. The desk accessory works like a fuel gauge (the solid bars indicate how much power is left).



For more information on how to use the Battery desk accessory, go to the power management chapter in Part III of this book.

Open the PowerBook control panel

The PowerBook control panel lets you control the balance between power consumption and system performance (it also lets you control other PowerBook features).

To open the PowerBook control panel:

1. Choose Control Panels from the Apple (🍏) menu.



2. Open the PowerBook icon.



(Click the icon once to select it, then choose Open from the File menu. Or double-click the icon.)

The PowerBook control panel appears. You drag the Battery Conservation slider to the left to improve performance (but battery power is used up more quickly) or to the right to conserve power (but the computer may work more slowly).

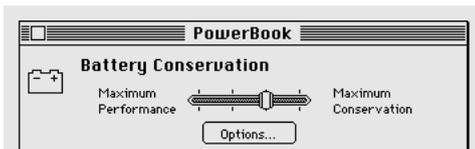

For more information on how to use the PowerBook control panel, go to the power management chapter in Part III of this book.

Use Balloon Help

Balloon Help explains icons, menus, commands, and other objects on the Macintosh screen, using balloons similar to those in comic strips. Each balloon points to the object it explains.

Many Macintosh programs also have Balloon Help.

Turn on Balloon Help

1. **Point to the Help icon near the right end of the menu bar.**
2. **Press to pull down the Help menu.**
3. **Drag to highlight the Show Balloons command, then release the trackball button.**

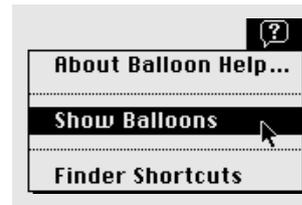

When Balloon Help is turned on, balloons containing explanatory text appear next to objects that you point to on the screen.

continues ►

4. To show a balloon describing your startup hard disk, point to the hard disk icon.

A balloon appears next to the icon. Balloons do not affect how you work with your computer. You still select icons, choose commands, and so on.

5. Click your hard disk icon to select it.

You can select the icon even with the balloon showing.

6. Point to the File menu.

A balloon appears next to the menu title.

7. Press to pull down the File menu.

The balloon disappears when you pull down the menu.

8. Slowly drag to highlight the Open command, and then release the trackball button.

Notice that a balloon appears next to a command if you pause briefly as you drag past it.

The hard disk window becomes the active window. To see more balloons, you can point to different parts of the window and to different icons in the window.

Turn off Balloon Help

Balloons can block items on the screen as you work, so you may wish to turn them off when you're finished reading.

- Choose Hide Balloons from the Help menu.

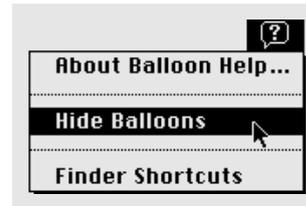

(Point to the Help icon in the menu bar, press to pull down the Help menu, drag to highlight the Hide Balloons command, and then release the trackball button.)

Use Part III of this book

Part III of this book, *Macintosh Reference*, contains all the information you need to use your computer's hardware and system software. Unlike Parts I and II, which are meant to be read from beginning to end, Part III is meant to be used like an encyclopedia: you turn to it when you need to look up some information, and read only that information.

To help you find the information you need, this book has a table of contents and an index. The back of the book also has a summary of commonly used skills, and a troubleshooting section.

What next?

Congratulations. If you've gone through the *Macintosh Basics* tour and Parts I and II of this book, you've seen and practiced all the basic skills you need to use your computer productively.

At this point, you could

- check your battery's charge and recharge it if necessary (see the power management chapter for more information)
- start learning how to use your application programs
- turn to Part III and find out how to organize your files or how to adapt your computer to your own use
- turn to any other topic in Part III that interests you
- take a break

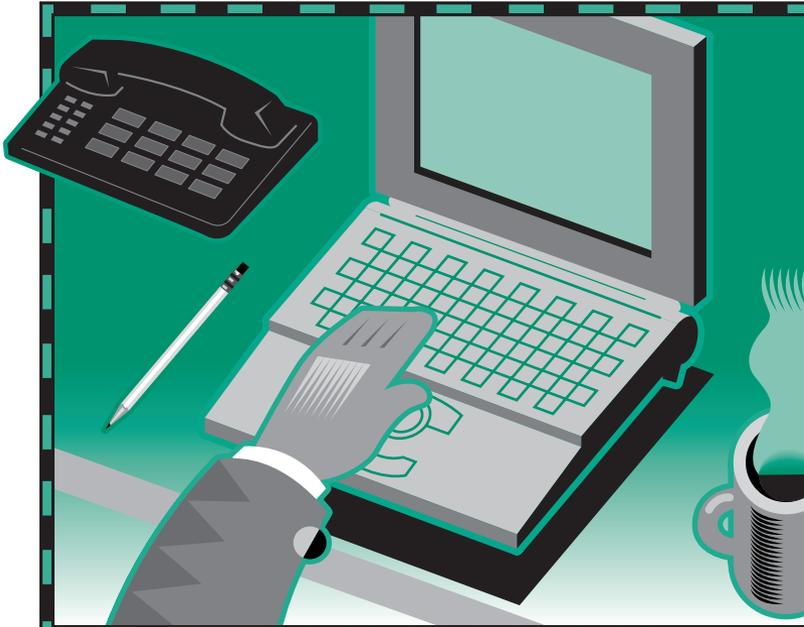

Chapter 6

Setting Up Your Programs

In this chapter

- Reinstalling system software
- Installing your programs
- Working with several programs at a time
- Using the Scrapbook
- Using a RAM disk

Reminder: Back up

If you didn't back up your computer's hard disk as described in Chapter 1, remember to do so soon. You will need the backup copy if you ever need to reinstall system software.

Reinstalling system software

System software is the set of programs and other files that your computer uses to start itself up, keep track of your files, and run the application programs you use. When you turn on your computer, it looks for a disk that contains the system software, which is always in a folder called the System Folder. Any disk that contains a System Folder with system software inside it is a startup disk. The startup disk is usually the hard disk that's inside your computer, though another hard disk or a floppy disk can also be a startup disk.

If your Macintosh cannot find a startup disk, it displays this icon in the middle of the screen:



If you see this icon, you need to reinstall system software on your computer's internal hard disk from a backup copy. See the section on restoring information on your hard disk in Chapter 8.

Installing your programs

Most application programs come on floppy disks, and you install them by simply copying them from the floppy disks to your hard disk. Some programs need to be installed in a particular way. If your program came with specific instructions, follow them.

To use your programs most effectively:

- Put only one copy of each program on your hard disk. Having more than one copy can lead to problems when you're using the program.
- Whenever you copy the contents of a program disk to your hard disk, be careful not to copy an extra System Folder. Always check to see what you've copied, and drag any extra System Folders to the Trash.
- Keep the original program disk in a safe place. If the program on your hard disk malfunctions, you can replace it with a fresh copy from the original disk.

- If a program malfunctions consistently, and installing a fresh copy does not correct the problem, find out from the software manufacturer whether your version of the program is compatible with the system software you're using.
- Put frequently used programs (or aliases for those programs) in the Apple menu so you can open the programs more conveniently. See the chapter on adapting your computer to your own use.
- If you want your computer to open a program automatically each time it starts up, you can put the program (or its alias) into the Startup Items folder. See the chapter on adapting your computer to your own use.

Installing programs without a floppy disk drive

If you have access to a network, you can connect your computer to the network and copy programs from a shared disk. See the chapter on networks.

Remember that the software license agreement for a given program may limit the number of copies you're allowed to make.

Installing system software from floppy disks

System software is a set of programs that your computer uses to start up and operate. If you purchased a system software update kit or have system software on floppy disks or on a shared disk on the network, use these instructions. To reinstall system software from a backup you have made, see “Restoring the Information on Your Hard Disk” in Chapter 8. You do not need to install system software if you see the Macintosh desktop on your screen when you turn on the computer.

If you are installing system software over a network, locate and open the Installer program and start with step 2.

- 1. Make sure your computer is off. Find the *Install* disk. Insert the disk into the floppy disk drive (metal end first, label side up). Turn on your computer.**

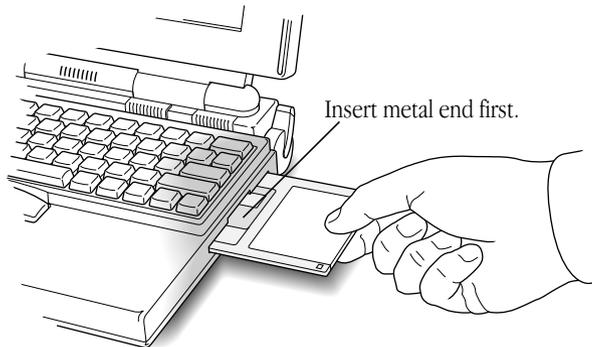

After a few moments, you'll see the Welcome box of the Installer, the program that installs system software on your hard disk.

- 2. Press the Return key on your keyboard to continue.**

The Easy Install dialog box appears. Easy Install puts the system software that you'll need right away onto your hard disk.

- 3. Press the Return key again to start installing system software.**

Messages on your screen report how installation is progressing.

continues ►

4. When the computer prompts you, remove the disk and insert the next disk the computer requests.

During installation, the computer automatically ejects a disk it has finished with and requests the next disk it needs. If you're installing over a network, you won't need to insert disks.

5. Insert the remaining disks as the computer prompts you.

6. When you see a message reporting that installation was successful, press the Return key once more to quit the Installer program.

If you see a message saying that installation was not successful, you need to try again. Follow the instructions on the screen.

Checking for computer viruses

Viruses—programs that damage files or erase disks—can be introduced into your computer from a floppy disk, from a shared disk on a network, or from an electronic bulletin board service.

Programs that detect and eliminate viruses are available from user groups, bulletin boards, and dealers.

You should check for viruses frequently if you exchange disks or data with other users. Some programs check for viruses automatically.

- Check all disks—even those in new, unopened commercial software packages—for viruses before using them or copying anything from them to your hard disk.
- Check your hard disk regularly with a virus-detection program and correct any problems the program finds.
- Since new viruses appear regularly, make sure you have the latest version of your virus-detection software.

- To avoid compatibility problems, be sure to use only one virus-detection program at a time.
- If your computer is on a network or if you use a modem, check for viruses each time you copy information from an outside source.
- If you give information to other computer users on disks or send information electronically, make certain that there are no viruses on your computer system before distributing the information.
- Make sure that you have a virus-free copy of your System Folder on floppy disks. Back up your System Folder immediately after you install new system software—before you install other software or open any programs.

Working with several programs at a time

You can open as many programs and desk accessories as your computer's memory allows.

All open programs are listed in the Application menu at the right end of the menu bar. The name of the active program (the one you're using right now) has a checkmark next to it, and its icon appears in the menu bar.

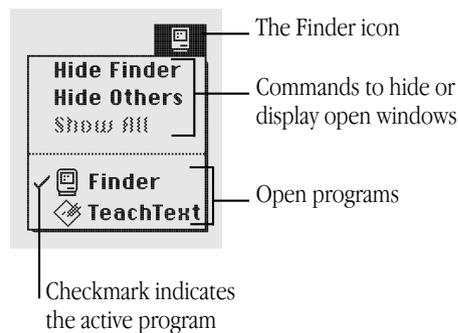

Finding out what programs are open

If you have several programs and windows open, you can find out which program is active and what other programs are open by pulling down the Application menu.

Switching programs

You can switch to another open program or desk accessory by choosing its name from the Application menu.

If a program's icon is dimmed in the menu, that means its windows are hidden. Choosing the program from the Application menu displays its windows.

You can also switch to another program by clicking in a window that belongs to an open program, or by double-clicking a program icon (or the icon of a document that was created with the program).

Hiding and showing windows on the desktop

You can hide all windows except those of the active program by choosing the Hide Others command from the Application menu.

The other programs remain open even though the windows are hidden. When you switch to another program, its windows are displayed.

If you want to see all the open windows, choose Show All from the Application menu.

Changing the amount of memory a program uses

Each program you open sets aside the amount of memory it needs. (If you don't have enough memory to open a program, you need to quit one of the programs already open to free up some memory.)

On occasion you may want to increase or decrease the amount of memory a program uses. You increase the amount so you can open more or larger documents in that program, and you decrease the amount so you can open more programs at the same time. You adjust the program's memory size in its Info window.

1. **Quit the program if it's open, and then click the program's icon to select it.**
2. **Choose Get Info from the File menu.**
3. **Drag across the box containing the number you want to change (either "Minimum size" or "Preferred size").**
"Preferred size" must always be larger than "Minimum size."
4. **Type the number of kilobytes (K) of memory that you want the program to use.**

If the program frequently runs out of memory, increase both the preferred size and the minimum size.

If you want to be able to open more programs, decrease the minimum size. If you type a size smaller than "Suggested size," the program may work more slowly, show other performance problems, or not work at all.

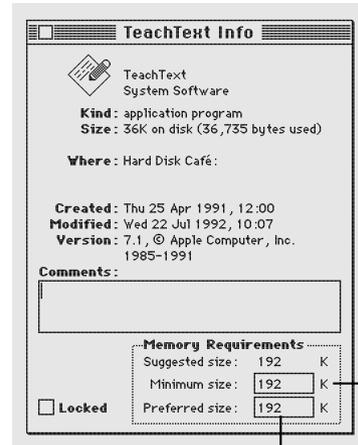

The amount of memory the program needs to open

The amount of memory the program will use if enough memory is available

5. **Close the Info window.**

If you make the memory size smaller than suggested, you'll see a message asking you to confirm your decision. Click Cancel to avoid problems with the program.

Using the Scrapbook

You can use the Scrapbook to store text, graphics, sounds, and other elements that you frequently include in your documents.

Storing items in the Scrapbook:

1. In your document, select the text or other element that you want to store in the Scrapbook.
2. Choose Copy from the Edit menu.
3. Choose Scrapbook from the Apple () menu.

The Scrapbook opens. You can use the scroll bar to see the different text, graphic, and other elements it contains.

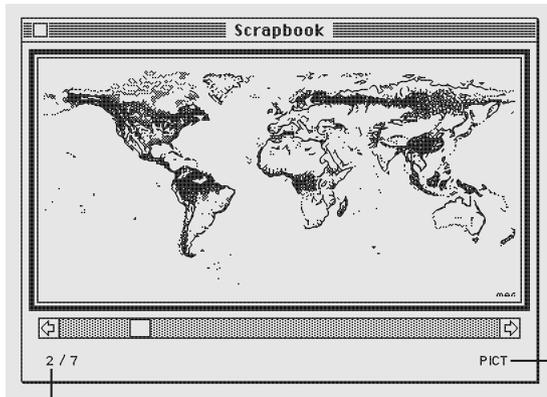

The second of seven items

The type of item of information displayed

4. Choose Paste from the Edit menu.

The new element is pasted ahead of the one previously displayed.

Copying items from the Scrapbook:

1. Choose Scrapbook from the Apple () menu.
2. Use the scroll bar to display the item you want to use in a document.
3. Choose Copy from the Edit menu.
4. Open the document you want to use the item in.
5. Decide where you want to place the element.
6. Choose Paste from the Edit menu.

Deleting items from the Scrapbook:

1. Choose Scrapbook from the Apple () menu.
2. Use the scroll bar to display the item you want to delete.
3. Choose Clear from the Edit menu.

Using a RAM disk

A *RAM disk* is a portion of your computer's memory that you set aside for use as a temporary storage device. Using a RAM disk conserves power because the computer uses less energy to access RAM than to access a hard disk or a floppy disk.

To use a RAM disk, you should have at least 4 MB of RAM in your computer because memory assigned to a RAM disk is not available for opening programs.

Choosing Sleep or restarting the computer does not affect a RAM disk—but if your computer has a built-in floppy disk drive, choosing Shut Down erases the contents of the RAM disk (but does not remove the RAM disk itself).

Remember a few precautions if you use a RAM disk:

- Before using a program on a RAM disk, test the program on your hard disk or a floppy disk to make sure that it works properly with your computer.
- Don't store your only copy of a file on a RAM disk. Keep a backup copy on your hard disk or a floppy disk.

Creating a RAM disk

1. **Choose Control Panels from the Apple (Ⓜ) menu.**
2. **Open the Memory control panel.**

The RAM disk portion of this control panel is at the bottom of the window. If your computer has less than 3 MB of RAM, this portion does not appear.

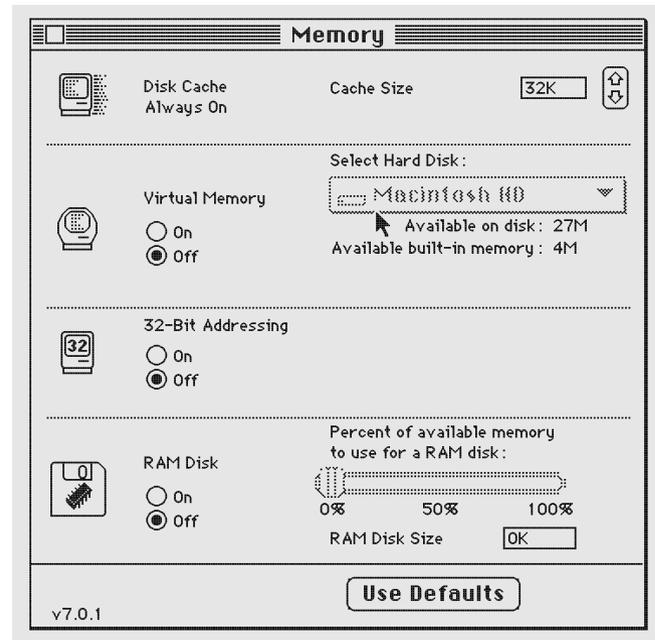

continues ►

3. **Click the On button below the words “RAM disk.”**
4. **Drag the slider to choose the percentage of available memory you want to use for your RAM disk.**

Choose a size just large enough to accommodate the programs and documents you want to put on the RAM disk. Don't choose a larger size than you need because memory set aside for the RAM disk won't be available for opening programs.

The size of the RAM disk you select appears in the “RAM Disk Size” box.

5. **Choose Restart from the Special menu.**

A RAM disk icon appears on the desktop when the computer restarts.

6. **Drag the items you want to the RAM disk icon.**

Erasing a RAM disk

There are two ways to erase the contents of a RAM disk. They do not remove the RAM disk itself or make more memory available for opening programs.

- **Select the RAM disk icon and choose Erase Disk from the Special menu.**
- **Drag everything on the RAM disk to the Trash and choose Empty Trash from the Special menu.**

Resizing or removing a RAM disk

1. **Copy any programs or documents that you want to save onto the internal hard disk or a floppy disk.**

If you want to resize a RAM disk, you need to remove its contents and then restore them.

2. **Drag everything in the RAM disk to the Trash.**
3. **Choose Empty Trash from the Special menu.**
4. **Choose Control Panels from the Apple (Ⓜ) menu.**
5. **Open the Memory control panel.**
6. **Drag the slider to choose the percentage of available memory you want to use for your RAM disk.**

Drag the slider to 0% if you want to remove the RAM disk.

7. **Choose Restart from the Special menu.**

If you resized your RAM disk, a new RAM disk icon appears on the desktop when the computer restarts. If you removed your RAM disk, no icon appears.

8. **If you resized the RAM disk, copy any items you want back to it.**

△ **Important:** The contents of the RAM disk are erased when you choose Shut Down, though the RAM disk itself is not removed. △

Chapter 7

Power Management

In this chapter

- Checking the battery level
- Responding to low-power messages
- Recharging the battery
- Removing or replacing the battery
- Maximizing battery life
- Getting the most work time out of the battery

Monitoring the battery charge level

Your computer's main power source is a nickel-cadmium battery. The battery provides power for up to 3 hours of work (the exact time depends on how often you use the hard disk, how bright the screen is, and other factors). Use the Battery desk accessory to monitor the charge level of the battery so you can recharge it when necessary.

Using the Battery desk accessory

To open the Battery desk accessory, choose Battery from the Apple () menu.

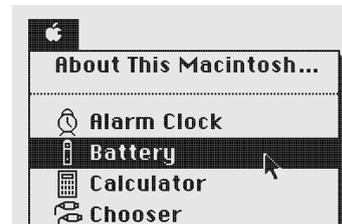

The Battery desk accessory appears.



The line of rectangles is the battery gauge. Black rectangles indicate the charge level. You can see the level decrease while the battery is in use, and increase while the battery is recharging in the computer.

When you click the lever to the right of the battery gauge, a Sleep button appears.

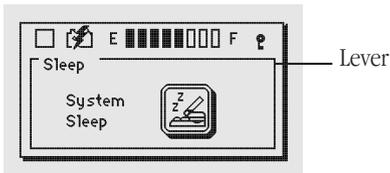

You may sometimes find it convenient to put the computer to sleep by clicking this button, instead of choosing the Sleep command.

Responding to low-power messages

When the battery charge drops to about 15%, the computer displays a series of low-power messages. The work time remaining after you see the first message will vary depending on how you are using the computer. It's a good idea to act promptly.

What you should do

When you see a low-power message, do either of the following:

- **Plug in the power adapter, *or***
- **Save your work and put the computer to sleep.**

What you should know

The first low-power message indicates that it's time to recharge the battery. Right after this message appears, the screen brightness dims automatically to save power.

If you continue to work without plugging in the power adapter, the computer displays a second low-power message.

The second message is followed almost immediately by a third and final message indicating that the computer is about to put itself to sleep. When time is up, the computer goes to sleep automatically to protect the contents of RAM.

If you continue working until the computer goes to sleep automatically, you may not be able to wake it again until you recharge the depleted battery in the computer for 15 minutes.

If you can't plug in the power adapter, the contents of RAM are retained in sleep for at least 2 days. If you leave the battery in the computer and recharge it within 2 days, you should be able to wake the computer and resume work where you left off.

△ **Important:** Recharge a depleted battery as soon as possible. Leaving a depleted battery in the computer for longer than 2 weeks (especially in a hot location, such as the trunk of a car) may damage the battery so that it can't be recharged. If this happens, you need to replace the battery. △

Recharging the battery

There are two ways to recharge:

- Plug in the power adapter to recharge the battery without removing it from the computer, *or*
- Remove the battery and recharge it in the (optional) recharger.

Recharging with the power adapter

Plug in the power adapter as shown.

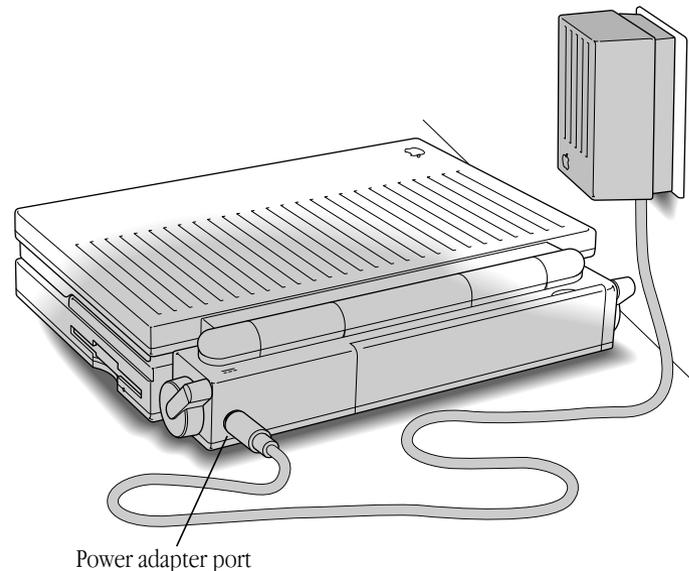

▲ **Warning:** Use only the power adapter that came with your computer. Adapters for other electronic devices (including other portable computers) may look similar, but they may damage your computer. ▲

A lightning bolt icon appears in the Battery desk accessory when the power adapter is plugged in and the battery is recharging. The lightning bolt icon disappears when recharging is about 85% complete, though recharging continues. The icon appears even if the power adapter is plugged into the computer only, so make sure the adapter is plugged into both the computer *and* an electrical outlet.

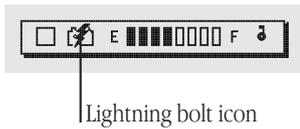

You can continue to use the computer while the battery is recharging, but the battery will take longer to recharge if you do. Battery recharging time while the computer is in use depends on how often you use the hard disk, how bright the screen is, whether you are using an external monitor, how deeply the battery is depleted, and other factors.

If you are using several of your computer's power-consuming features (such as an external monitor and a program that requires frequent hard disk access), and you are *not* using the features designed to conserve power (such as processor cycling), the battery may not recharge until you put the computer to sleep or shut it down.

If you recharge a fully depleted battery with the computer shut down, it takes about 2–3 hours to bring the battery to 80% of its capacity. It takes several more hours to bring the battery charge to 100%.

While the computer is shut down and the power adapter is plugged in, you can remove a charged battery from the computer and replace it with a battery you want to charge. If you do this, disconnect and then reconnect the power adapter after inserting the second battery (otherwise the second battery will not recharge).

Recharging with a recharger

A battery recharger and additional batteries are available as options for your computer. If you purchase a recharger and an extra battery, you can charge one battery while you use the other, so you always have a fully charged battery on hand.

The recharger can accommodate two batteries. The battery slots work independently, so you can put batteries in or take them out at different times.

The recharger must be plugged into an electrical outlet to charge a battery. You can plug it in using the power adapter that came with your computer, or you can purchase an additional (identical) power adapter from your authorized Apple dealer.

▲ **Warning:** Do not use any other type of power adapter with the recharger. Doing so may damage the recharger, the power adapter, or both. ▲

To recharge a battery, follow these steps.

1. **Place the recharger on a level surface.**
2. **Connect the recharger and the power adapter as shown in the illustration.**

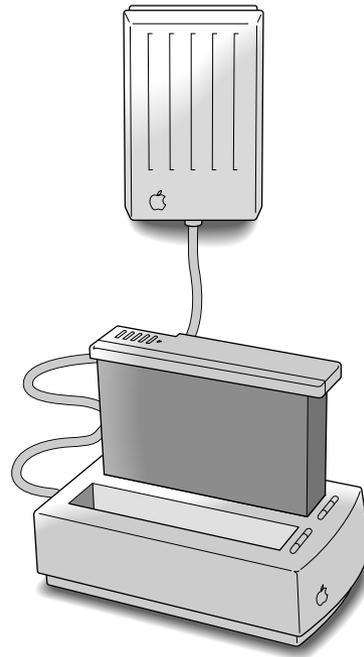

3. Place the battery in the recharger as shown.

Recharging begins immediately. You can remove a battery from the recharger at any time.

△ **Important:** To preserve a battery's charge, don't leave it in the recharger if the power adapter is not plugged into an electrical outlet. △

The lights on the recharger indicate the following:

- **No light:** The recharger is not plugged in, or the battery is defective. (If the light goes off during recharging, there is a problem with the battery.)
- **Yellow:** The battery is charging.
- **Green:** The battery is charged to at least 80% of its capacity, and can be used.

The table shows approximate recharging times for fully depleted batteries.

	80% charge	100% charge
In the recharger:		
1 battery	2.5 hours	5 hours
2 batteries	5 hours	10 hours
In the computer (shut down):	2–3 hours	6–8 hours

Removing or replacing the battery

Don't attempt to use your computer without a battery (even when the power adapter is plugged in).

To remove or replace the battery, follow these steps.

1. **Save your work, and then choose Shut Down from the Special menu.**
2. **Close the display.**
3. **Open the battery door by sliding the door in the direction indicated by the arrow.**

The door is physically attached to the battery.

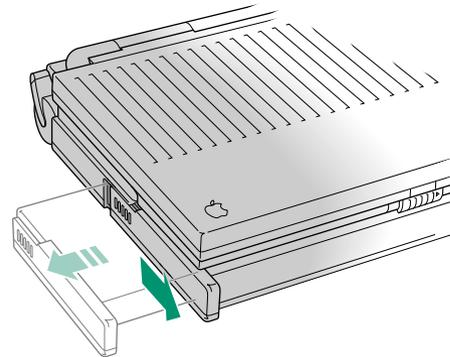

4. **Carefully pull the battery out of its compartment.**
5. **If you are inserting another battery, slide it into the battery compartment.**

Replacement batteries come with a door attached.

6. **Close the battery door by pushing it back into place.**
7. **If you just inserted a new battery, it's a good idea to plug in the power adapter in case the battery is not fully charged.**

△ **Important:** Nickel-cadmium batteries contain metals which are hazardous when released to the environment. It is inappropriate, and in some cases unlawful, to throw batteries away with your household or business trash. Instead of throwing away your spent batteries, dispose of them as described here.

In the United States: Return spent batteries to your authorized Apple service provider, who will make sure they are included in Apple's battery recycling program.

Elsewhere: Many locations have government or Apple-sponsored collection and/or recycling programs for spent batteries. Dispose of spent batteries in accordance with the mandatory or voluntary battery collection schemes in your location. Contact your authorized Apple service provider for information about the recommended battery disposal procedures in your area. △

▲ **Warning:** Damaged nickel-cadmium batteries may leak small amounts of potassium hydroxide. This substance can cause severe burns to the skin and eyes. If you touch a damaged battery, immediately wash your hands and any other affected areas with water for at least five minutes. *Do not use soap.* ▲

Maximizing battery life

To maximize battery life, discharge and then recharge the battery completely once every 90 days. Just use the computer as you normally would, but ignore the low-power messages that appear on the screen. (Make sure to save your work, however.) When the computer goes to sleep automatically, recharge the battery completely before using that battery again. You can do this in either of two ways:

- Leave the battery in the computer, plug in the power adapter, and let the battery recharge overnight, *or*
- Remove the battery from the computer and recharge it in a recharger for 5 hours (if you are recharging just one battery) or 10 hours (if you are recharging two).

Your battery will last longer if you recharge it at or slightly below room temperature.

With proper care you can expect your battery to last for at least a year. If you notice that the battery no longer holds a charge for as long as it should, you may need to replace it.

Maximizing work time

Your PowerBook's battery can provide up to 3 hours of work time before you need to recharge it. The actual work time available depends on what equipment you're using with your computer and what steps you take to conserve power while you work.

Ways to conserve battery power

The more of these steps you take, the longer you can use your battery before recharging it.

- Turn down the screen brightness whenever possible. At its brightest level, the screen consumes about a third of the power your computer is using.
- Adjust the battery conservation settings in the PowerBook control panel for maximum conservation: set the battery conservation slider at Maximum Conservation; keep processor cycling turned on. The rest of this section describes these settings in detail.
- Keep virtual memory turned off in the Memory control panel.
- Quit any program that uses a modem unless you're using the program for telecommunication. As long as the program is open, your modem is consuming power.
- If you're working near an electrical outlet, plug in the power adapter.
- If you aren't using the computer, put it to sleep and plug in the power adapter.

Adjusting the battery conservation settings

The Battery Conservation section of the PowerBook control panel gives you several ways to regulate your computer's power consumption.

The easiest approach

Just use the Battery Conservation slider to choose the setting you prefer.

1. **Choose Control Panels from the Apple () menu, and open the PowerBook control panel.**
2. **In the Battery Conservation box, drag the slider to the setting you want.**

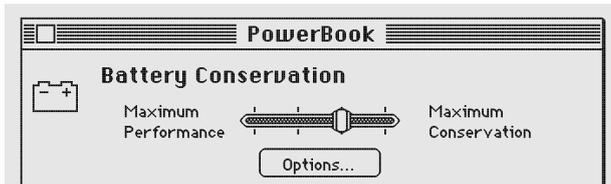

There are four settings along the scale. If you're trying to meet a deadline, Maximum Performance allows you to work with the fewest interruptions. If you don't have a power adapter with you, Maximum Conservation gives you the longest work time.

When you change the setting, the new setting takes effect immediately.

3. Close the PowerBook control panel.

You can think of the battery conservation setting as an automatic sleep setting. If you don't use the computer for several minutes (how many depends on which setting you choose), it goes to sleep without any action on your part. A computer in sleep has a darkened screen and appears to be off, though it is still drawing battery power at a low level.

To put the computer to sleep before the automatic sleep setting takes effect, choose Sleep from the Special menu.

To wake the computer from sleep, press any key (except Caps Lock).

Automatic sleep does *not* take effect under any of the following circumstances:

- The AppleTalk software is turned on in the Chooser and the power adapter is plugged in. (Automatic sleep does take effect if the power adapter is not plugged in.)
- Your computer is connected to a shared disk on the network.
- Your computer's printer or modem port is in use.

More about automatic sleep

The Battery Conservation slider controls two different power conservation features: system sleep and hard disk sleep.

- System sleep is a state in which your computer uses only the power it needs to maintain the contents of RAM. (The contents of RAM include any open programs and documents, and various control panel settings such as the clock time.)
- Hard disk sleep stops your computer's internal hard disk from spinning when it isn't being used.

If system sleep is in effect, so is hard disk sleep.

The table indicates how the battery conservation settings correspond to sleep times.

	Minutes before sleep if you choose:			
	Performance		Conservation	
System	15	8	4	1
Hard disk	15	4	2	0.5

Using the battery conservation options

The Battery Conservation section of the PowerBook control panel includes a button labeled Options. Click this button to see more options that affect your computer's power consumption.

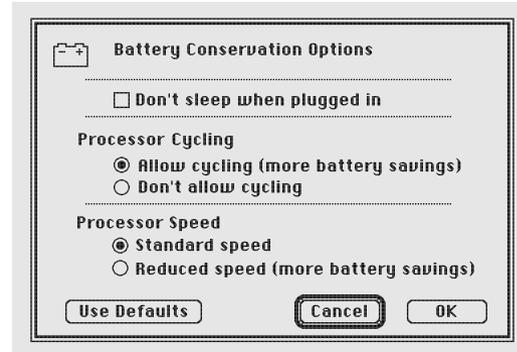

Don't sleep when plugged in

If the power adapter is plugged in, you can prevent automatic sleep by clicking "Don't sleep when plugged in."

Processor cycling

If the computer is not doing anything for a few seconds, it reduces the power consumption of its microprocessor. The microprocessor comes back up to speed instantaneously when you resume work. This feature is called processor cycling.

You don't need to do anything to use the processor cycling feature. But if you notice that one of your programs performs very slowly, you might want to turn off processor cycling while using that program.

To turn off processor cycling, follow these steps.

1. **Choose Control Panels from the Apple menu, and open the PowerBook control panel.**
2. **Click the Options button.**
3. **Click “Don't allow cycling.”**

Processor Cycling

- Allow cycling (more battery savings)
- Don't allow cycling

4. Close the PowerBook control panel.

To turn processor cycling back on, click “Allow cycling.”

You may notice other effects of processor cycling. For example, if you have open programs doing something in the background, processor cycling may slow those programs down. You may also notice that the Alarm Clock is updated irregularly or that the wristwatch pointer appears more often. These changes do not indicate a problem with your computer.

When you turn processor cycling off, the computer drains the battery faster. The computer may also become very warm to the touch, especially on the side beneath the keyboard. These changes do not indicate a problem with your computer. However, you should keep processor cycling turned on whenever possible.

△ Important: To conserve battery power, turn processor cycling off only when using programs that it interferes with. Turn processor cycling back on again as soon as possible. △

Chapter 8

Using Disks

In this chapter

- Preparing a new disk for use
- Erasing a disk
- Choosing a startup disk
- Protecting the information on a disk
- Restoring the information on your hard disk
- If you can't save files on a floppy disk
- Ejecting a disk
- Caring for disks
- Testing and repairing disks

Preparing a new disk for use

Before you can use a new disk, you need to prepare it so the computer knows where to store information on the disk. This preparation is called *initializing* (or *formatting*) the disk.

- ❖ *Note:* You don't need to initialize the floppy disks that are used for backing up your system. The PowerBook 145B Backup program initializes them for you automatically. ❖

The hard disk inside your computer is initialized at the factory, but you need to initialize new 3.5-inch (89-millimeter) floppy disks that you want to use in a floppy disk drive.

Initializing a hard disk

Occasionally a hard disk may become damaged in such a way that you have to reinitialize it. (The key symptom of such damage is that the hard disk's icon does not appear on the desktop when you start up the computer using another disk.) You lose all the information on a damaged disk when you reinitialize it.

If your hard disk's icon does not appear on the desktop, first try to repair it as described later in this chapter. If you can't repair the disk, use the Apple HD SC Setup program to reinitialize the disk. The program is on the *Disk Tools* disk that came with your computer.

1. Insert *Disk Tools* and turn on your computer.
2. Locate the Apple HD SC Setup icon and open it.



The name of the hard disk currently selected is shown as the “volume name.” The SCSI ID number of the selected hard disk is displayed above the Drive button. (The ID number of an internal hard disk is 0.)

3. Click Drive until the disk you want to initialize appears.

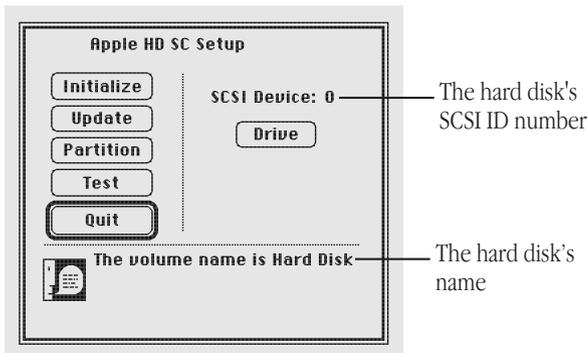

You cannot initialize the disk that you used to start up your computer or the disk that contains the Apple HD SC Setup program.

4. Click **Initialize**.
5. Click **Init** to initialize the hard disk.
6. If a message appears asking you to name the disk, type a name and then click **OK**.
7. Click **Quit** when you see a message reporting that initialization was successful.

If a message reports that initialization failed, try again. If initialization fails a second time, take the disk to your authorized Apple service provider for repair.

Initializing a floppy disk

Initializing a new floppy disk prepares the disk to store information.

1. Insert a new floppy disk into your floppy disk drive.

If you inserted a high-density disk (1.4 MB), this message appears:



If you inserted a double-sided (800K) disk, this message appears:



2. If you inserted a high-density disk, click **Initialize**. If you inserted a double-sided disk, click **Two-Sided**.

A message alerts you that you're about to erase any information that may be on the floppy disk. A new floppy disk has no information on it.

3. Click **Erase**.

A third message asks you to name the disk.



4. Type a name for the disk.

If you don't name the disk, the computer gives it the name "Untitled."

5. Click **OK**.

The computer takes about a minute to initialize the disk. When initialization is finished, the icon of the floppy disk appears on the desktop.

Erasing a floppy disk

Erasing a disk actually reinitializes it.

▲ **Warning:** When you erase a disk, you lose any information that was on the disk. ▲

1. **Click the icon of the disk you want to erase.**
2. **Choose Erase Disk from the Special menu.**

A message appears.

3. **Depending on the type of disk you're erasing, click Initialize or Two-Sided.**

The computer takes about a minute to erase the disk.

Designating a startup disk

If you use more than one hard disk with your computer, you can specify which hard disk you want the computer to use as the startup disk. (A startup disk must have a System Folder on it that contains the correct version of the system software.)

If you don't specify a startup disk, your computer uses its internal hard disk as the startup disk (if it has a System Folder).

1. **Choose Control Panels from the Apple (Ⓜ) menu.**
2. **Open the Startup Disk control panel.**
3. **Click the icon of the disk you want to use as the startup disk.**



4. **Close the Startup Disk control panel.**

Scanning order for startup disks

When you turn on your computer, it looks for a startup disk (a disk containing a System Folder) in the following sequence:

1. internal floppy disk drive (if any)
2. external floppy disk drive (if any)
3. disk (or RAM disk) selected in the Startup Disk control panel
4. internal hard disk
5. external hard disk (if there is more than one, it looks first at the hard disk with the highest SCSI ID number)
6. internal hard disk (the computer returns to this drive and waits another few seconds)

If the computer does not find a startup disk, it displays a blinking question mark in the middle of the screen.

To bypass the internal hard disk in the scanning sequence, press ⌘-Option-Shift-Delete while the computer starts up.

△ **Important:** If you use an external hard disk, turn it on and wait a few seconds before you turn on your Macintosh, or the computer may not recognize the disk. △

Protecting the information on a disk

The information on a locked floppy disk or in a locked file can be opened or copied but cannot be changed.

Locking a floppy disk

- Slide the tab on the back side of the disk so that the square hole is open.

Use your thumbnail, a push pin, or a similar object to move the tab.

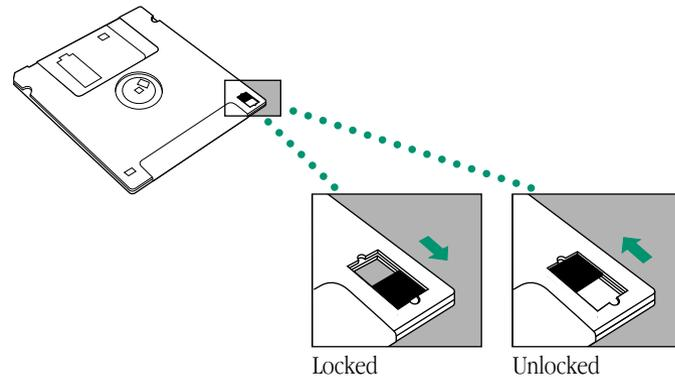

To unlock the disk, slide the tab back so that it covers the square hole.

Locking a file

You use the Get Info command to lock a document or a program. Locking a program may affect its operation.

1. **Click the icon of the file you want to lock.**
2. **Choose Get Info from the File menu.**
3. **In the Info window, click the Locked box in the lower-left corner.**

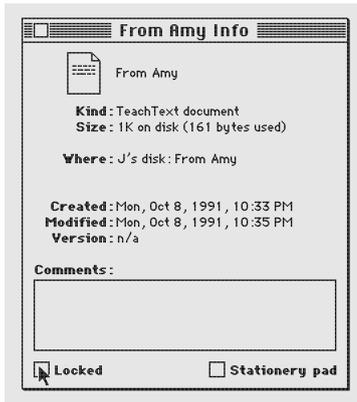

4. Close the Info window.

To unlock the file, click the Locked box again (so the X disappears).

You can't lock a folder, but you can lock items in a folder.

Locking an alias does not lock the original file. Locking an alias merely protects it from being thrown away.

Backing up your files

You can back up the work you store on a hard disk by copying individual files onto another disk in the usual way (dragging their icons to the icon of the other disk). You can back up the contents of an entire floppy disk by dragging its icon to another floppy disk icon or a hard disk icon.

Use the application program called PowerBook 145B Backup to copy the entire contents of your Macintosh hard disk onto floppy disks. Keeping this backup copy up to date will protect you in case information on your hard disk is accidentally lost or damaged.

You should update your backup copy at least once a month, and in between full backups you should store copies of important documents on floppy disks. It's a good idea to keep two sets of backup copies, and to alternate between them (using one set one month, and the other the next) when updating your backup copy. This protects you from losing your files in case something goes wrong with one set of disks.

You can also purchase a backup program with additional features that make copying faster. (For example, some programs have a feature that lets you copy only the new and changed information on your hard disk.)

If something happens to the information on your hard disk, you can use the backup copy you made to put the information back onto your hard disk. To do this, you use the PowerBook 145B Restore program that came with your Macintosh. See “Restoring the Information on Your Hard Disk” later in this chapter.

Using PowerBook 145B Backup for the first time

When you use the PowerBook 145B Backup program for the first time, you should make a copy of your System Folder, and then a copy of all the files on your hard disk. Follow these steps:

1. **Open the PowerBook 145B Backup program by double-clicking its icon.**

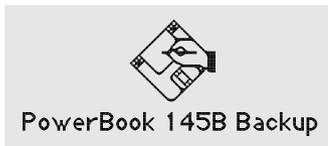

The PowerBook 145B Backup program opens.

2. **Make sure your floppy disks are high-density. Then click the Continue button.**

A message appears, telling you how many high-density disks you need to make the copy and approximately how long it will take. Make sure you have enough time and disks to complete the copying. If you stop the copying before it's finished, you'll have to start over again from the beginning.

3. **Click the appropriate button.**
 - The first time through, click Copy System Folder.
 - The second time through, click Copy All Files.
4. **Insert a high-density floppy disk into the disk drive.**
5. **Follow the instructions on the screen until a message tells you that you're finished. As you remove each disk from the computer, label it so you can find it again later.**
6. **Repeat steps 1-5 and make a backup copy of all files on your hard disk.**
7. **When you're finished, be sure the floppy disks are properly labeled and locked, then store them in a safe, cool place.**

Using PowerBook 145B Backup to update your backup copy

Keeping your backup copy up to date will protect you in case information on your hard disk is accidentally lost or damaged. You can use the floppy disks that contain a backup copy of all the files on your hard disk.

Don't update your backup copy of the System Folder. Save this in case you need to reinstall system software.

To use PowerBook 145B Backup to update your backup copy, follow these instructions:

1. Get the floppy disks that you used to make a previous backup copy.

Have some extra high-density disks on hand in case there is more information on your hard disk than there was the last time you made a copy.

2. Turn on your Macintosh, if it's not already on.

3. Open the PowerBook Backup 145B program by double-clicking on its icon.



The PowerBook 145B Backup program opens.

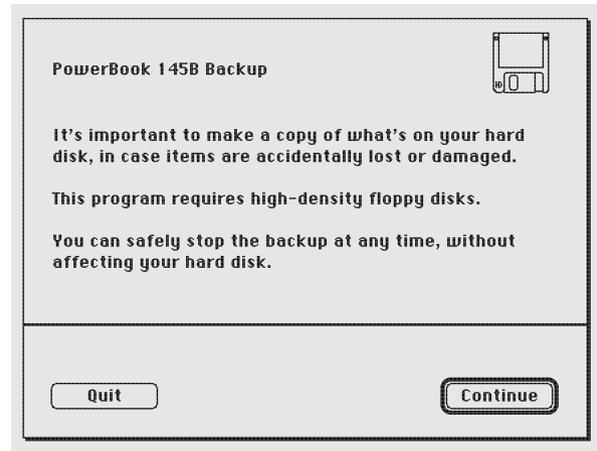

4. Make sure your floppy disks are high-density. Then click the Continue button.

A message appears, telling you how many high-density disks you will need to copy all files on your hard disk, or to copy just the System Folder. It also tells you approximately how long it will take to make the copy.

5. Click the button that corresponds to your choice.

Make sure you have enough time and disks to complete the copying. If you stop the copying before it's finished, you'll have to start over again from the beginning.

6. Unlock the disk labeled 1.

To unlock the disk, turn the disk label-side down and use a pen or your fingernail to slide the tab in the lower right corner of the disk so that it covers the square hole. (The disk has two square holes, but only one of them has a tab.)

7. Insert the disk into the floppy disk drive.

If you did not unlock the disk correctly, it is ejected and a message appears. Unlock the disk, making sure that the tab snaps into place, and try again.

A message appears, telling you that the disk contains information. If you click the Continue button, all the information currently stored on the disk is erased.

8. Click the Continue button.

If there is a problem with the disk, a message appears. Otherwise copying takes place automatically. A sound alerts you when it's time to insert another disk.

9. When the first disk is ejected, repeat steps 7 through 9 for the next disk in your stack of backup disks. Be sure to lock and label the disks as they are ejected.

10. The PowerBook 145B Backup program lets you know when you're finished. Be sure to store the disks in a safe, cool place.

Restoring the information on your hard disk

If information on your hard disk becomes damaged or lost, you can restore it if you have a backup copy of the information. You can use the program called PowerBook 145B Backup that came with your Macintosh to make a backup copy of the information on your hard disk. The program called PowerBook 145B Restore can put that information back on your hard disk.

You can also use PowerBook 145B Backup to make a copy of your System Folder (the folder that contains the software the Macintosh uses to operate). If your Macintosh does not start up any more, replacing the System Folder may solve the problem. You can use PowerBook 145B Restore to replace the damaged System Folder on your hard disk.

For instructions on using PowerBook 145B Backup, see “Protecting the Information on a Disk” earlier in this chapter.

△ **Important:** If at any time during restoring, you see a message reporting that the hard disk is damaged or unreadable, turn to “Testing and Repairing Disks” later in this chapter. △

To restore information from your backup floppy disks to your hard disk, follow these steps:

1. **Get the floppy disk labeled *Disk Tools* that came with your computer and the floppy disks that you used to back up your hard disk.**
2. **Make sure your Macintosh is off.**
3. **Insert the *Disk Tools* floppy disk into the floppy disk drive, then turn on your Macintosh.**
4. **Locate the PowerBook 145B Restore icon.**

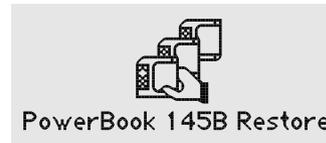

continues ►

5. Open the PowerBook 145B Restore icon by double-clicking it.

In a moment you'll see this screen:

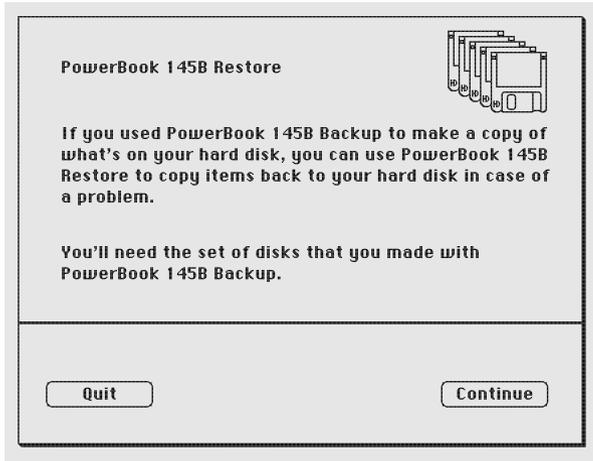

6. Read the information on the screen and click the Continue button.

7. Insert the backup disk labeled 1.

Restoring proceeds automatically.

8. Respond to any messages you see on the screen.

If PowerBook 145B Restore finds an item on your hard disk that is newer than an item with the same name on the floppy disk, you are asked whether you want the older version of the item to replace the newer version. Click the choice you want. If you think the item on the hard disk may be damaged, you should replace it.

9. Repeat steps 7 and 8 for the next disk in your stack of backup disks.

Make sure you insert disks in the correct order.

10. The PowerBook 145B Restore program lets you know when you are finished. Store your backup disks in a safe, cool place.

11. Restart your Macintosh and make sure that everything is back on your hard disk.

If the Macintosh still does not start up or your hard disk still does not work properly, see "Testing and Repairing Disks" later in this chapter. If you are able to repair the disk, then try again to restore the information on your hard disk.

Restoring your System Folder

If your Macintosh does not start up any more, replacing the System Folder may solve the problem. If you used PowerBook 145B Backup to make a backup copy of your System Folder, you can use PowerBook 145B Restore to replace the damaged System Folder on your hard disk with a fresh copy from your backup disks.

To restore the System Folder to the hard disk, follow the instructions in the section “Restoring Information on Your Hard Disk,” using floppy disks containing a backup copy of your System Folder.

If you can't save files on a floppy disk

If you can't save files on a floppy disk, the disk may be locked, full, or damaged, or the disk drive may not be working properly. Try the following:

- Make sure the tab on the back of the disk is in the unlocked position (the square hole should be closed).
- If you see a message reporting that the disk is full, erase unneeded files from that disk, or save on another disk.
- If you see a message that the disk is not initialized, and you know that it has been initialized, eject the disk and carefully insert it again. If the same message appears, the disk is probably damaged. You may be able to recover its information with Disk First Aid or another disk-recovery program. (See the section on testing and repairing disks in this chapter.)
- Check the disk for obvious damage to the plastic case or the sliding metal shutter.
- Insert a different disk and try saving again. If you can't save on the second disk, the disk drive may be damaged. Take the disk drive to your authorized Apple service provider for repair.

Ejecting a disk

You can eject a floppy disk by doing any of the following:

- Click the disk icon to select it and choose Put Away from the File menu.

The disk is ejected and its icon disappears from the desktop.

- Drag the disk icon to the Trash.

The disk is ejected and its icon disappears from the desktop. (Dragging a disk to the Trash does not erase the disk's contents.)

- Click the disk icon to select it and choose Eject Disk from the Special menu.

The disk is ejected and its dimmed icon remains on the desktop.

You can use the first two methods to remove a hard disk icon from the Macintosh desktop (provided that it's not your startup disk), or to disconnect from a shared disk on the network.

All three methods also work with CD-ROM discs.

If you can't eject a floppy disk

If you can't eject a floppy disk in the usual way, try the following in order:

1. Hold down the \mathbb{C} and Shift keys and press the number 1 key on your keyboard to eject a disk in an internal disk drive; press \mathbb{C} -Shift-2 to eject a disk in an external disk drive.
2. Turn off the Macintosh. If the disk isn't ejected, then hold down the trackball button while you turn the computer on again.
3. Locate the small hole near the disk drive's opening, and carefully insert the end of a large straightened paper clip into it. Push gently until the disk is ejected. Do not use excessive force.

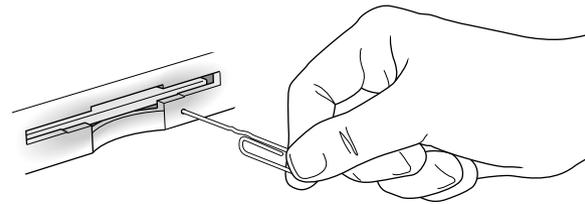

4. If nothing works, take the computer or disk drive to your authorized Apple service provider to have the disk removed.

Caring for disks

For information on floppy disk care, see the section on working with disks in Part II of this book, or consult the instructions that came with your floppy disks.

Hard disk precautions

Hard disk drives are delicate mechanisms and should be handled with care.

- Do not bump, jar, or move your computer while the hard disk is in use. If you need to move the computer, wait until the hard disk stops spinning.
- Do not spill any liquids on or near the hard disk.
- Do not expose the hard disk to hazardous vapors, such as those from cleaning solvents.

Testing and repairing disks

Both floppy disks and hard disks can become damaged by repeated use and handling. If you see a message reporting that a disk is damaged or unreadable, you can use Disk First Aid or Apple HD SC Setup to try to diagnose and correct the problem. Both programs are on the disk called *Disk Tools* that came with your computer.

If a hard disk icon doesn't appear

If you can't start up from a hard disk or don't see its icon on the desktop, try the following:

- If the hard disk is internal, shut down your Macintosh, wait at least 10 seconds, and then turn it on again.
- If the hard disk is your startup disk, start up with a different disk. If the hard disk's icon appears on your desktop, reinstall the System Folder on the hard disk using your backup copy.

continues ►

- If the hard disk is external, make sure it is turned on and its cable is connected firmly; then restart the Macintosh.
- Check the ID numbers of all SCSI equipment connected to your computer. Each device must have a unique ID number (the computer itself has the ID number 7, and the internal hard disk has the number 0). Also check that the chain of devices is terminated properly. (See the chapter on enhancing your computer system for information about setting SCSI ID numbers and checking termination.)

Using Disk First Aid

You can use the Disk First Aid program to test floppy disks and hard disks that may have been damaged. Disk First Aid also repairs some types of disk damage. Disk First Aid is on the *Disk Tools* disk that came with your computer.

1. **Insert *Disk Tools* and start up your computer.**
2. **Open the Disk First Aid icon.**



3. Click the Drive button until the name of the disk you want to test appears. Click the Eject button if you want to insert a different floppy disk.
4. Click Open.
5. Choose **Repair Automatically** from the Options menu.



6. Click the **Start** button to begin testing the disk.
7. **When testing and repair are finished, choose Quit from the File menu.**

If you want to test another disk, choose Close from the File menu, then select and open another disk (repeat steps 3–7).

If Disk First Aid cannot correct the problem:

- Try repairing the disk again. Sometimes repeating the process corrects the problem.
- Use another disk repair or recovery program. Some disk repair programs let you recover information from a damaged disk.
- Consult a specialist for help.
- Once you have recovered all the information you can, erase (reinitialize) the disk. If initialization doesn't work, discard the damaged floppy disk, or take the hard disk to your authorized Apple service provider for repair.

Testing a hard disk

You can test a hard disk with the Apple HD SC Setup program, which is on the *Disk Tools* disk that came with your computer.

1. **Insert *Disk Tools* and start up your computer.**
2. **Open the Apple HD SC Setup icon.**



3. **Click the Drive button until the disk you want appears.**

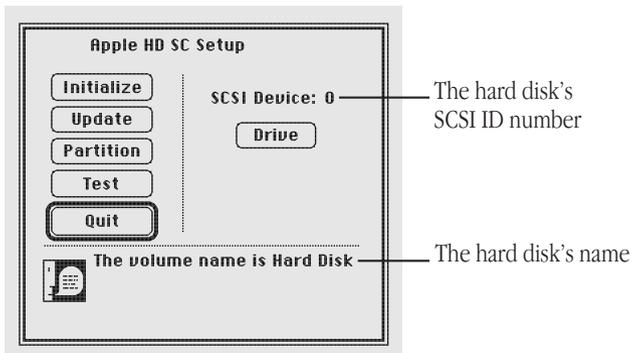

4. **Click Test.**
5. **When a message tells you that testing is complete, click Quit.**

If the test reveals a problem, you may be able to correct it by using Disk First Aid or another disk repair program, or you may have to reinitialize the disk. Consult a specialist for assistance if necessary.

Chapter 9

Organizing Your Files

In this chapter

- Straightening up your files
- Using folders to organize your files
- Filing documents when you save them
- Making items easier to find
- Finding an item
- Creating a template or stationery
- Getting information about your files
- Assigning a label to a file
- Tips on transferring files

Straightening up your files

To accomplish this . . .	Do this . . .
--------------------------	---------------

Straighten up all icons in the active window	Choose the Clean Up command from the Special menu
Straighten up selected icons only	Hold down the Shift key while choosing Clean Up
Arrange icons alphabetically by name, or by the list view displayed most recently in that window	Hold down the Option key while choosing Clean Up
Line up icons near the right edge of the desktop	Click the desktop, then hold down the Option key while choosing Clean Up

You can also have icons arrange themselves in a staggered grid when you choose Clean Up. See the chapter on adapting your computer to your own use.

Using folders to organize your files

Macintosh folders, like the paper folders in a file cabinet, can be used to store and organize your work. You can place one folder inside another to create a hierarchy of files.

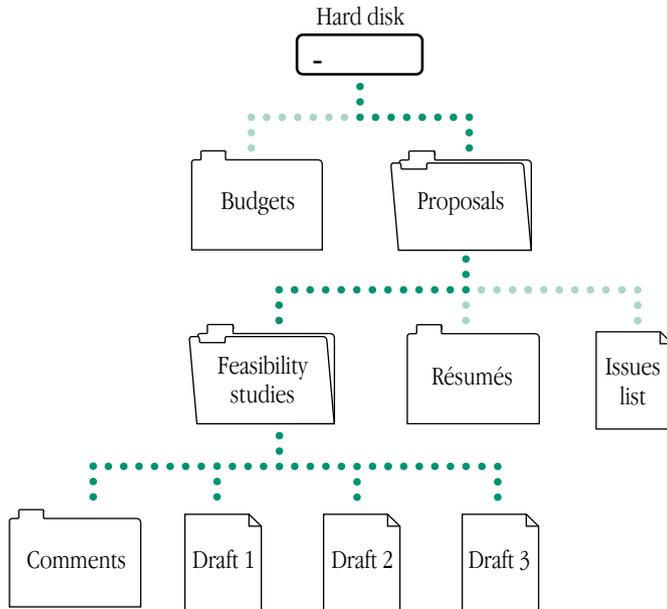

Creating and naming folders

You can create a new folder whenever the Finder is the active program.

1. Choose New Folder from the File menu.

A new folder appears in the active window (or on the desktop if no window is active). The name is already selected.

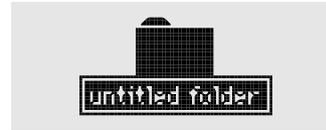

2. Type a name for the folder and press Return.

If this doesn't work, click the folder's name to select it, and try again.

You move, copy, and remove folders in the same way that you do other icons.

Many programs also let you create and name a new folder in the dialog box that appears when you save a document.

Filing documents when you save them

The first time you save a document (or whenever you choose Save As to create another version of that document), a directory dialog box appears. A directory is the list of files and folders contained in a folder or on a disk.

You use this box to name your document and indicate where to store it. Directory dialog boxes vary slightly from program to program, but all share certain features.

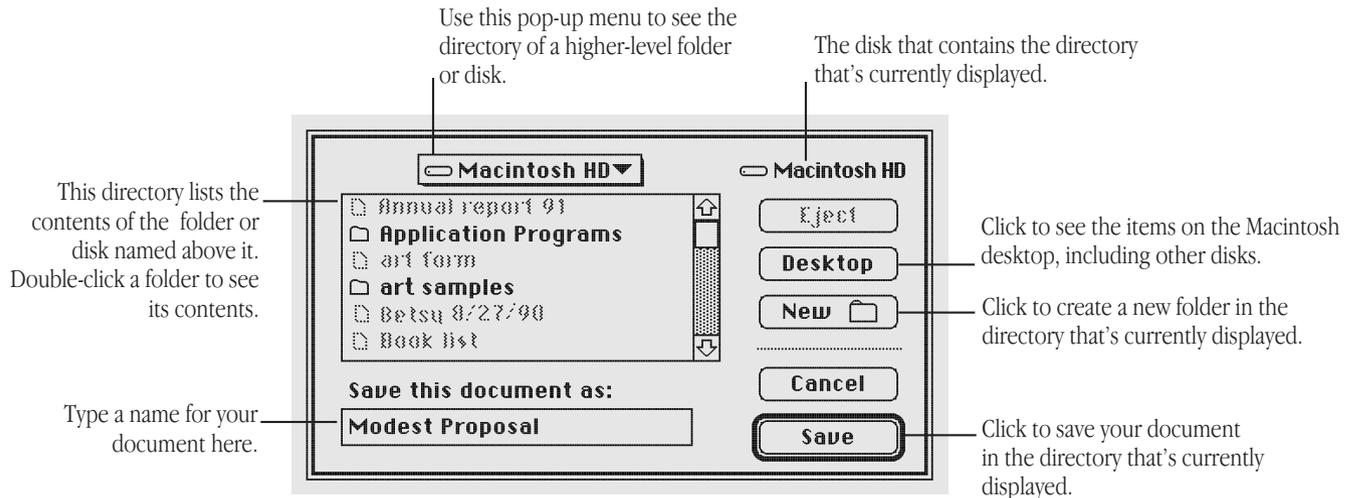

Making items easier to find

Your Macintosh provides several ways to make a file, folder, or other item easy to find and open. You can

- create aliases for the item and put the aliases in convenient locations
- install the item (or its alias) in the Apple (🍏) menu
- move the item (or its alias) to the desktop

Creating an alias

An alias represents and points to a file, folder, disk, or other item (even a shared item on a network). You can make as many aliases for an item as you want.

- 1. Click to select the item you want to make an alias for.**
- 2. Choose Make Alias from the File menu.**

The name of the alias appears in italics and ends with “alias.”
- 3. If you wish, type a new name for the alias (the name is already selected), and then move it to a new location.**

Uses for aliases

Alias for	Location	Purpose
Any item that could be stored in several places	Everywhere the item belongs	You can get access to an item from several places.
Apple Menu Items folder	On the desktop	You can easily add or remove Apple menu items.
A program that must stay with certain files	On the desktop; in the Apple menu	You can start the program without opening the folder or disk where it is stored.
A document or folder stored on a separate disk	Anywhere on your work disk	When opened, the alias asks for the disk by name, then opens the original when the disk is inserted.
An item on a shared disk	Anywhere on your work disk	When opened, the alias automatically connects to the shared disk and opens the item.

- ❖ *Trouble?* If you open an alias and nothing happens, or if you see a message that the original file isn't available, then the original has been deleted or the alias is damaged. You can open the alias's Info window to find out where the original is. ❖

Locating the original of an alias

An alias's Info window shows the location of the original.

1. **Select the alias whose original you want to find.**
2. **Choose Get Info from the File menu.**

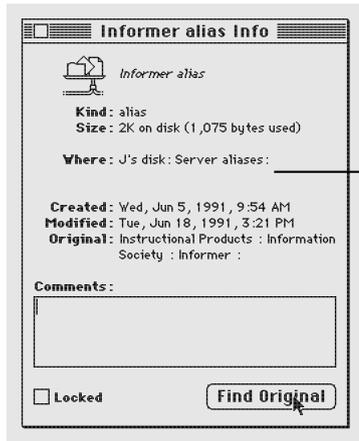

Location of the original—includes folder levels and disk name (if the original is on a different disk)

3. **Click the Find Original button.**

The window containing the original item opens. The icon is selected. (If the original is on another disk, you're asked to insert the disk.)

If you deleted the original, or if it is on a shared disk that's not available, you'll see a message that the original can't be found. Aliases are not deleted when the original is deleted (and vice versa).

Installing an item in the Apple menu

You can install any item in the Apple menu, and then open the item by choosing it from the menu.

1. **Open the System Folder icon and locate the Apple Menu Items folder.**
2. **Drag the item you want to install (or its alias) into the Apple Menu Items folder.**

The item appears immediately in the Apple menu.

You remove an item from the Apple menu by opening the Apple Menu Items folder and dragging its icon out of the folder.

- ❖ *Trouble?* If the Apple menu does not contain the items it should, make sure that the Apple Menu Items folder is in the System Folder of your startup disk. If it is, open the folder to check that all the items you want in the menu appear there. ❖

Moving an item to the desktop

You can make an item easy to find by dragging its icon to the desktop. The icon stays there until you remove the disk on which the item is stored.

If you've placed an icon on the desktop, you can put it back in its original location by selecting the item and choosing Put Away from the File menu.

Finding an item

When the Finder is the active program, you can use the Find command in the File menu to find any item on any disk connected to your computer. (The Find command cannot locate items inside the System file. You need to open the System file to see its contents.)

Finding an item by name

1. Choose Find from the File menu.

The dialog box that appears lets you find an item by name.

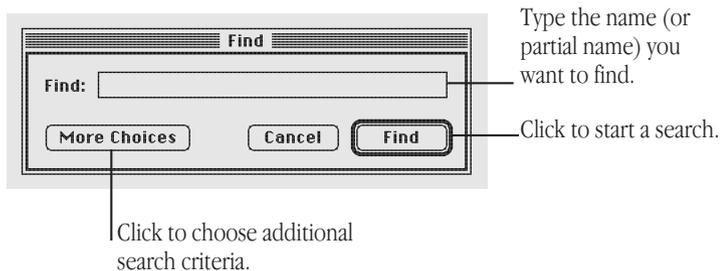

If the dialog box you see has more items than shown here, click the Fewer Choices button in the lower-left corner.

2. Type the name (or part of the name) of the item you want to find.

Capitalization does not have to match.

3. Click the Find button.

The first item that matches the name you typed is shown highlighted in a Finder window. If an item is found on the desktop, you see a message. If no item matches, you hear an alert sound.

4. To see the next matching item, choose Find Again from the File menu.

If no more items are found, you hear an alert sound.

Finding an item using other criteria

You can use the Find command to find items by size, label, date, or other characteristics.

1. Choose **Find** from the **File** menu.
2. If you see a button labeled **More Choices**, click the button.

The dialog box that appears lets you select search characteristics using pop-up menus.

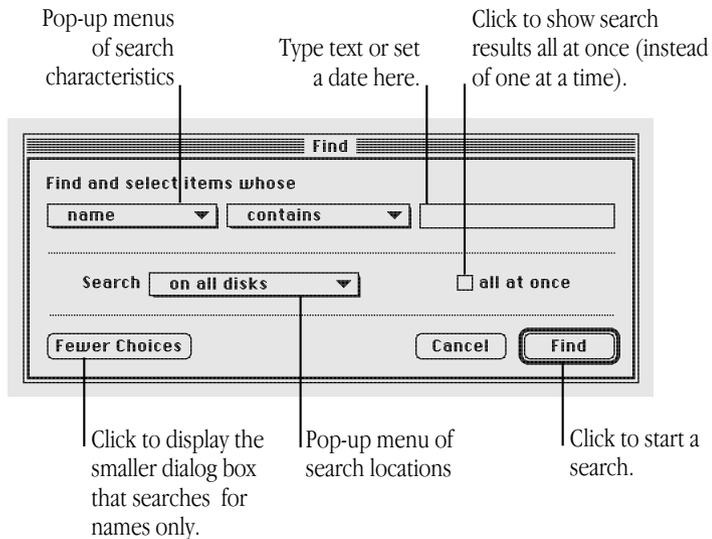

The content of the middle pop-up menu and the text area vary according to the item selected in the left pop-up menu.

3. Choose an item from the left pop-up menu.
4. Choose an item from the middle pop-up menu.
5. Adjust the date, choose an item, or type text in the upper-right area of the dialog box.

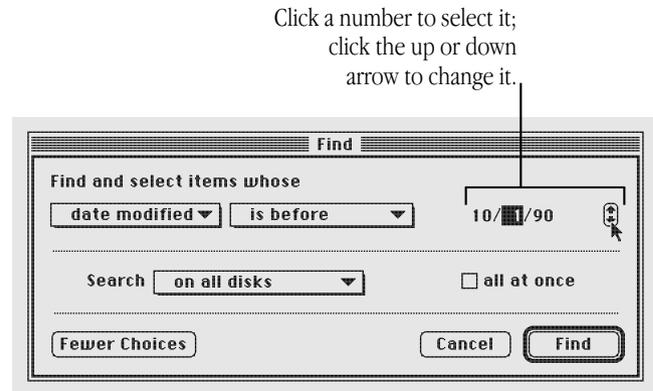

continues ►

6. Choose a search location from the pop-up menu labeled Search.

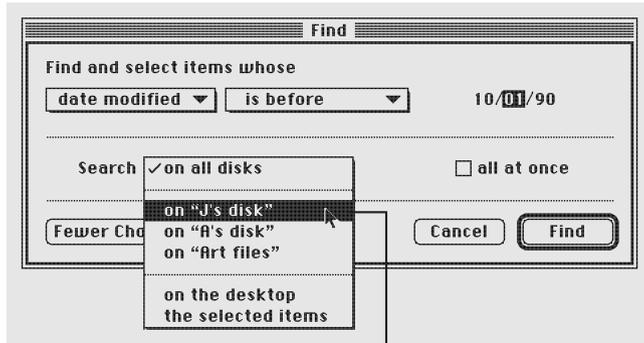

Location for the search

7. If you want all items displayed at once, click the checkbox labeled “all at once.”

8. Click the Find button when you’ve finished selecting options.

The first matching item is shown highlighted in a Finder window. To see the next matching item, choose Find Again from the File menu. If the item is found on the desktop, a message appears. If no item is found, you hear an alert sound.

When you display items all at once, they are shown highlighted in an outline view.

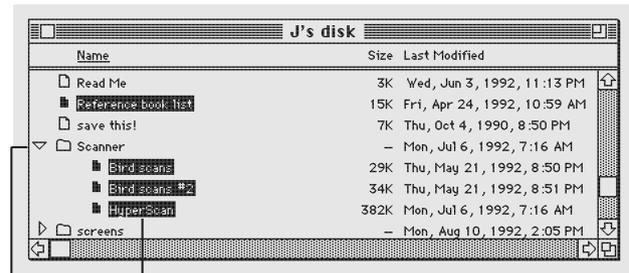

A list view, in outline form, shows the contents of folders.

Indentation means that an item is located inside a folder.

Finding items that meet two criteria

You can locate items that meet two sets of criteria, such as all items created before a certain date and larger than a certain size.

1. **Choose the first criterion.**
2. **Click the “all at once” box so that an X appears.**
3. **Click the Find button.**

The items found are shown highlighted in an outline view.

4. **Choose the Find command again, before you click or take any other action.**

You choose Find immediately so that the items located in the first stage of the search remain highlighted.

5. **Choose the second criterion.**
6. **Choose “the selected items” in the pop-up menu labeled Search.**
7. **Click Find to begin the second stage of your search.**

The items meeting both criteria are highlighted.

Ways to use the Find command

The Find command can help you locate files quickly, organize documents, and develop an efficient system for backing up and archiving your work.

This characteristic	Can be used to locate
Name	1. Files whose names you can't recall exactly 2. All items for which you use a standard name, such as status reports or expense reports
Kind	1. All application programs 2. All aliases
Size	Large files, to make space available on a disk
Label	All the files to which you added the same label (such as “top secret”)
Lock	Locked files, to unlock them for editing
Modification date	All files changed since a certain date, to back up new and changed files
Creation date	All files created before a certain date, to archive or erase outdated material

Creating a template or stationery

Most documents can be saved as or converted into a stationery pad, which is a template form of the document. The template retains its format and content, and you can use it repeatedly as a master for similar documents with different content.

Many programs let you save a document as a stationery pad when you choose Save or Save As. Click the stationery pad option to save your document as a template.

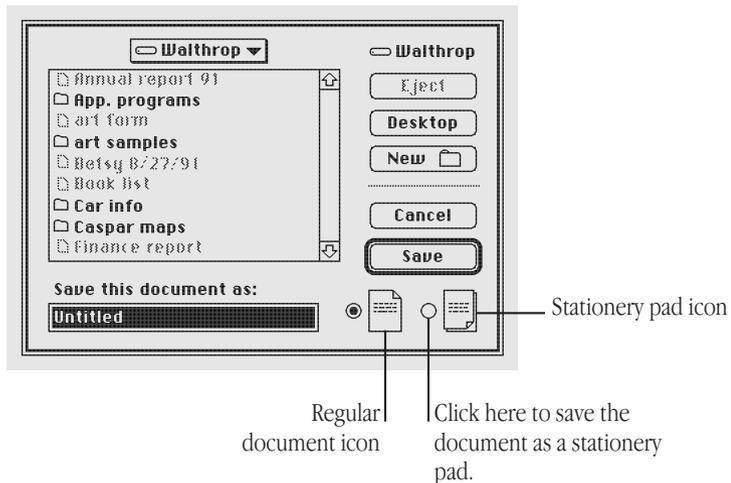

If the program you're using does not offer a stationery pad option, you can use a document's Info window to create a stationery pad.

1. **Click the document icon to select it.**
2. **Choose Get Info from the File menu.**
3. **Click "Stationery pad" near the lower-right corner so that an X appears in the checkbox.**

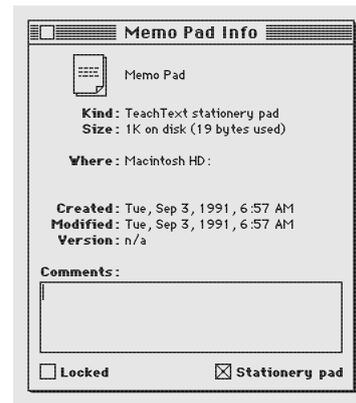

4. Close the Info window.

The document icon now appears as a stationery pad icon.

When you open a stationery pad, an untitled window appears showing the contents of the stationery, or a dialog box appears asking you to name the new document.

If you want to change the stationery pad itself you must first turn it back into a regular document. You can do this by opening the stationery pad's Info window and clicking "Stationery pad" to remove the X.

Getting information about your files

When the Finder is the active program, you can obtain information about your files in two places:

- in the file's Info window
- in the View menu

Using the Info window

The Get Info command displays information about a selected item.

1. Click to select the item you want information about.
2. Choose Get Info from the File menu.

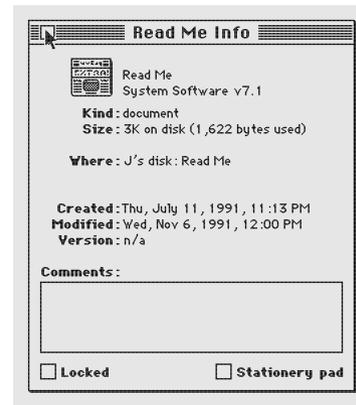

You can type comments in the Info window and use the Find command to search for them later.

3. Close the window.

Using the View menu

You can use the View menu to display the contents of a window by icon or small icon, or you can list items according to various characteristics such as name, size, or kind. (You can use the Views control panel to change how files are listed and what information is included in the list. See the chapter on adapting your computer to your own use.)

Windows are preset to show icons. You can also display items in a list by choosing a command from the View menu. For example, listing items by the date and time of their most recent modification makes it easy to back up files you have changed recently.

The type of list displayed is underlined.

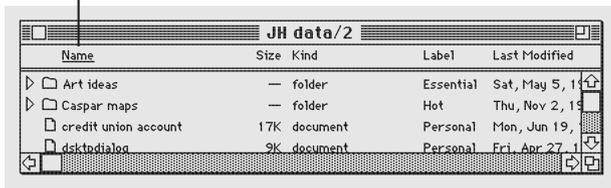

When the contents of a window are displayed as a list, you can click any column heading (such as Size or Last Modified) to rearrange the list according to that characteristic.

Assigning a label to a file

You can assign a label to a file and then group related files according to the label you have given them.

To assign a label to an icon, click the icon to select it and then choose the label you want from the Label menu. Choose By Label from the View menu to regroup your files. The label is visible only when the contents of a window are displayed as a list.

Tips on transferring files

You can transfer files from your computer's internal hard disk in the following ways:

- Over a network

You can connect your computer to a network and transfer files over the network. For information, see the networking chapter.

- Over telephone lines

If your computer is connected to a modem or has a modem installed, you can transfer files over telephone lines using an appropriate communications program. For more information, see the chapter on expanding your computer system.

- On floppy disks

If your computer has a built-in floppy disk drive or is connected to an external floppy disk drive, you can transfer files from your computer's internal hard disk to a floppy disk. (If your computer does not have a built-in floppy disk drive, see the chapter on expanding your computer system for instructions on connecting a disk drive.)

- On another hard disk

If your computer is connected to another hard disk, you can transfer files from your computer's internal hard disk to another hard disk. For instructions on connecting a hard disk, see the chapter on expanding your computer system.

Chapter 10

Adapting Your Computer to Your Own Use

In this chapter

- Specifying which items you want opened at startup
- Installing an item in the Apple menu
- Installing files in the System Folder
- Changing the labels in the Label menu
- Setting the time and date
- Setting a time for the Alarm Clock to go off
- Turning the alarm off
- Changing time and date formats
- Changing number and currency formats
- Adjusting the way the trackball or mouse works
- Adjusting the way the keyboard works
- Making keyboard shortcuts easier to type
- Adjusting the keyboard for very slow typing
- Adjusting the blinking of a menu item
- Adjusting the blinking of the insertion point
- Changing the way the contents of windows appear
- Changing an icon
- Turning off the Empty Trash warning
- Managing memory
- Setting the beep sound
- Installing a sound
- Removing a sound
- Recording sounds
- Changing the background pattern
- Magnifying the screen image

Specifying which items you want opened at startup

To have a program or a document open automatically when you start up your computer, drag its icon or its alias to the Startup Items folder, which is inside the System Folder. Programs or documents that you put in the Startup Items folder are opened when you start up your computer. You can open as many files as your computer's memory allows.

If you no longer want a file to open automatically when you start up your computer, remove the icon or alias from the Startup Items folder.

Installing an item in the Apple menu

To have an item's name appear in the Apple (🍏) menu, drag its icon or its alias to the Apple Menu Items folder, which is inside the System Folder.

You remove an item from the Apple menu by opening the Apple Menu Items folder and dragging the item out of the folder.

Installing files in the System Folder

Certain files need to be installed in the System Folder so your computer can use them as part of the system software. These files include

- system extensions and control panels
- preferences for application programs
- software that controls printers, scanners, and other equipment
- sounds
- fonts

Usually, you install these files by dragging their icons to the System Folder icon (not the System Folder window). Sometimes these files need to be installed by a program that comes with the files. Check the instructions that came with the files for any specific installation procedure.

Most special files are stored in folders inside the System Folder. When you drag a file's icon to the System Folder icon, your computer recognizes which type of file it is and stores the file in the appropriate folder.

This folder holds networking and printing software and files that extend your computer's capabilities.

The System file holds sounds, and keyboard files.

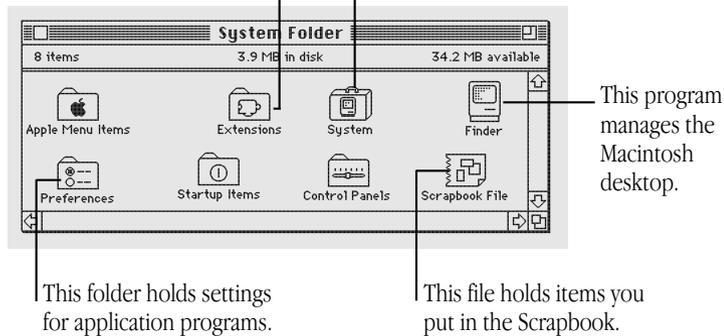

If you drag an item to the System Folder window instead of the System Folder icon, the file is not stored in the appropriate folder automatically, and it may not work properly.

Items you want in the Apple Menu Items folder or the Startup Items folder need to be dragged to either folder directly. (This chapter has instructions for installing Apple menu items and specifying the items you want opened at startup.)

Removing files from the System Folder

You remove a file from the System Folder by dragging its icon out of the System Folder.

Depending on the equipment you use, whether or not you're on a network, and how you use your computer, you can remove the following items from your System Folder if you want to conserve space on your startup disk:

- software for printers or other devices you don't use (for example, the AppleTalk ImageWriter driver)
- networking software, if you are not on a network (and don't plan to be) and don't use AppleTalk Remote Access
- Apple menu items you don't use (you need the control panels, but you may not need the Calculator or the Puzzle, for example)
- fonts, sounds, or keyboard files you don't use

Be sure you have backup copies of the files on floppy disks before you remove them from your System Folder.

Changing the items in the Label menu

You can change the labels in the Label menu. You make these changes in the Labels control panel.

1. **Choose Control Panels from the Apple (🍏) menu and open the Labels control panel.**



2. **To change a label, drag across it to select it and then type your new label.**

Setting the time and date

Your computer has a clock that keeps track of the time and date (a battery keeps it running when the computer is turned off).

Many programs rely on the clock to automatically enter times and dates in documents you create or print, and the Finder uses it to keep track of when files are created or changed.

1. **Choose Control Panels from the Apple (🍏) menu and open the Date & Time control panel.**



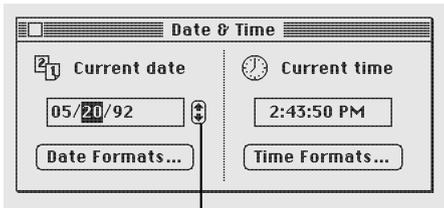

To set the date, click the month, date, or year to select it, then click the up or down arrow (or type the new number).

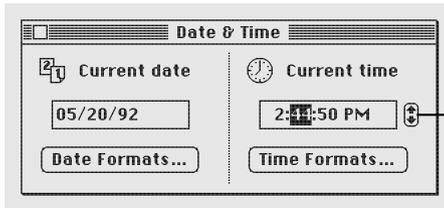

To set the time, click the hours, minutes, or seconds to select them, then click the up or down arrow (or type the number).

You can also set the time and date using the General Controls panel or the Alarm Clock.

Setting a time for the Alarm Clock to go off

You can set the Alarm Clock to alert you when it's time for an appointment or a meeting.

1. **Choose Alarm Clock from the Apple (🍏) menu.**
2. **Click the upward-pointing lever near the upper-right corner to expand the Alarm Clock.**

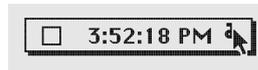

The lever points downward, and the Alarm Clock expands to its full size.

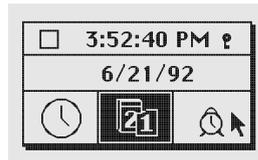

continues ►

3. Click the alarm clock icon in the lower-right corner to select it.

The alarm clock icon becomes highlighted when you select it. The time that appears in the middle section is the current alarm clock setting.

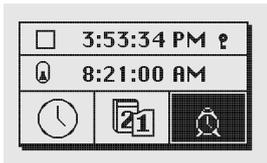

4. Click the hours, minutes, or seconds in the alarm clock setting to select them.

Up and down arrows appear to the right of the time display.

5. Click the up or down arrows repeatedly until the number you want appears.

6. Repeat steps 4 and 5 as necessary.

7. Click the button to the left of the alarm clock setting to turn the alarm on.

The button and the alarm clock icon change to indicate that the alarm is turned on. (Clicking again turns the alarm off.)

Button in the upper position indicates that the alarm is on.

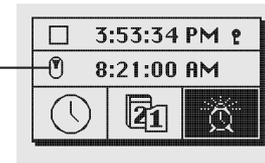

Icon showing ringing alarm

8. Click the close box to close the Alarm Clock.

The alarm will not go off unless you close the Alarm Clock, click the lever to make the Alarm Clock smaller, or make another window active.

Turning the alarm off

When the system clock reaches the time set for the alarm, the alert sound plays twice and an alarm clock icon blinks over the Apple icon at the left end of the menu bar.

To turn off the alarm, choose Alarm Clock from the Apple (🍏) menu and click the button to the left of the alarm clock setting.

Changing time and date formats

You can change how times and dates appear based on personal preference or local custom.

Changing the date format

1. Choose Control Panels from the Apple (🍏) menu and open the Date & Time control panel.
2. In the Date & Time control panel, click Date Formats.

3. In the dialog box that appears, make the changes you want.

A sample of the format you choose appears at the bottom of the dialog box.

4. Click OK to close the control panel.

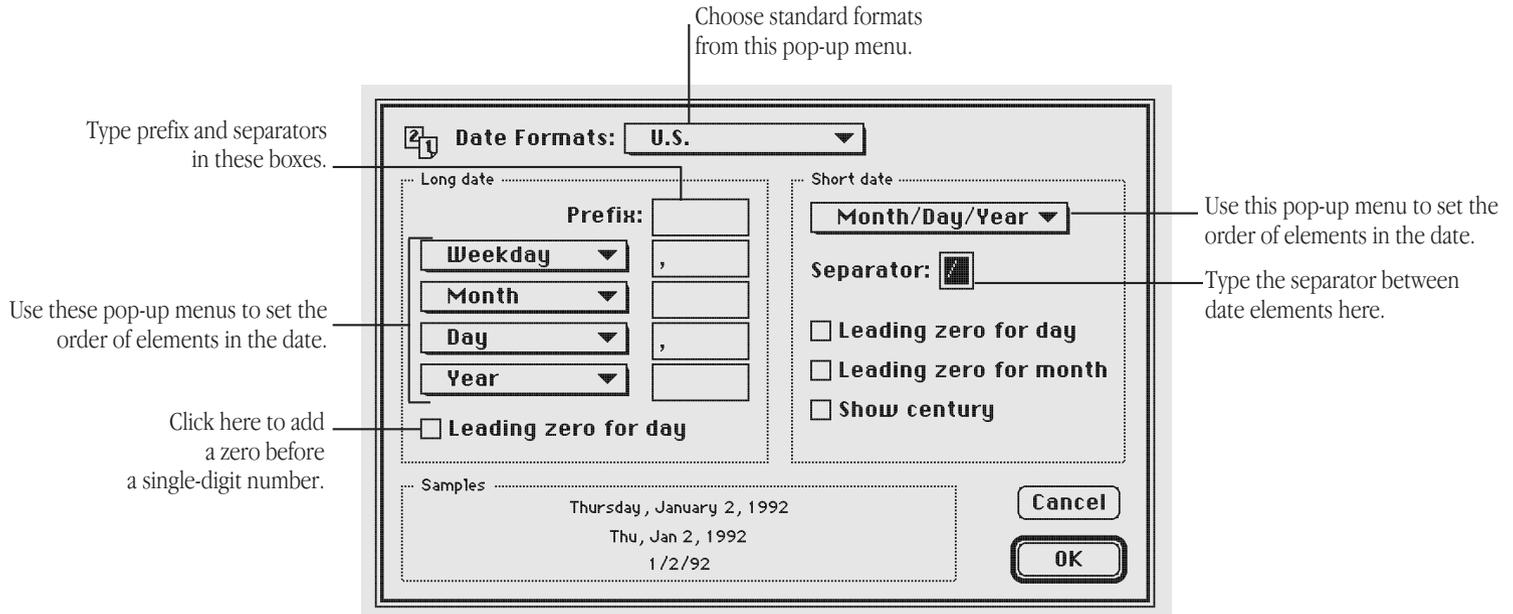

Changing the time format

1. Choose Control Panels from the Apple (🍏) menu and open the Date & Time control panel.
2. In the Date & Time control panel, click Time Formats.

3. Make the changes you want.

A sample of the format you choose appears at the bottom of the dialog box.

4. Click OK to close the control panel.

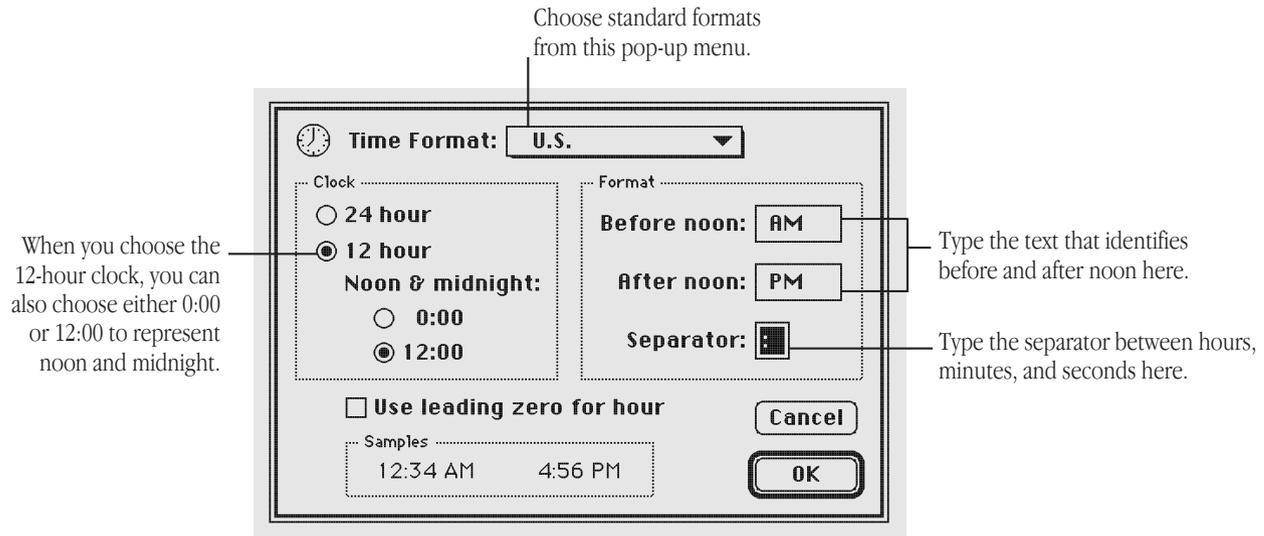

Changing number and currency formats

You can choose among several formats for displaying numbers and currency.

1. **Choose Control Panels from the Apple () menu and open the Numbers control panel.**



2. **Make the changes that you want.**
3. **Close the control panel.**

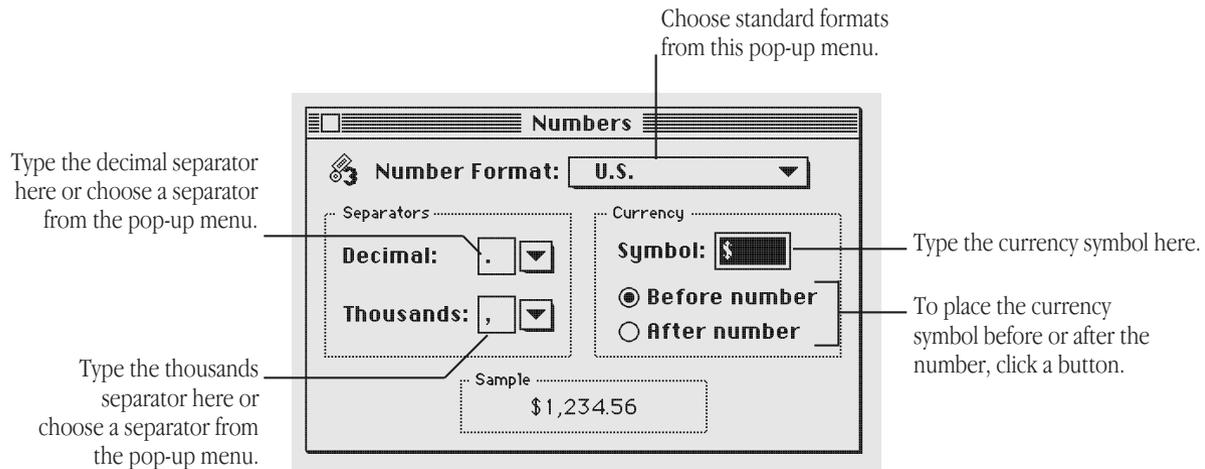

Adjusting the way the trackball or mouse works

You can adjust two aspects of trackball or mouse operation in the Mouse control panel: tracking, which is the relation between trackball or mouse movement and pointer movement on the screen, and double-clicking speed.

1. Choose Control Panels from the Apple (🍏) menu and open the Mouse control panel.

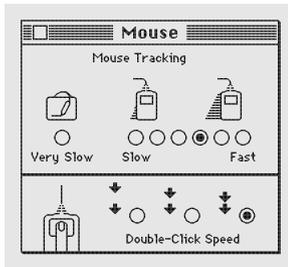
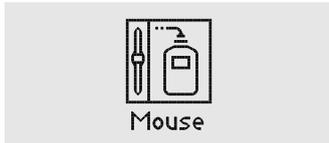

2. Click the tracking speed you want.

The Very Slow option is useful for drawing or for a graphics tablet because the pointer moves at a constant speed relative to trackball or mouse movement.

3. Click the double-clicking speed you want.

Adjust the double-clicking speed if your computer often interprets two clicks as a double click, or a double click as two single clicks.

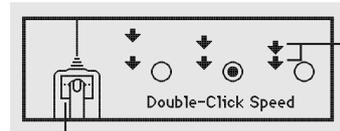

The space between arrows corresponds to the time between clicks.

Mouse button highlights twice at the interval selected.

4. Close the control panel.

Adjusting the way the keyboard works

You can adjust the rate at which a character repeats when its key is held down as well as the delay before the character begins repeating. You can also change the keyboard layout if you have additional keyboard layouts installed.

1. **Choose Control Panels from the Apple (🍏) menu and open the Keyboard control panel.**

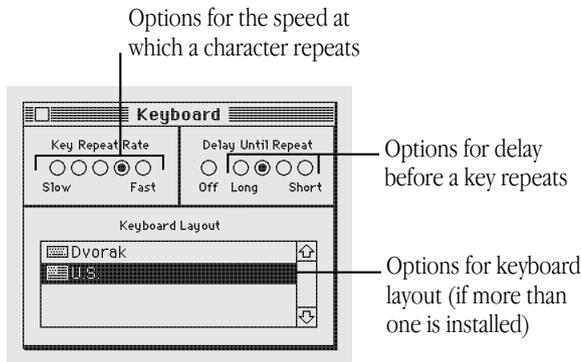

2. **To adjust the rate at which a key repeats when it is held down, click the button for the rate you want.**
3. **To adjust the delay before keys repeat, click the button for the delay you want.**

If the keys repeat when you don't want them to, set a longer delay before a character begins repeating. (If you click the Off button, the keys don't repeat at all.)

4. **To change the keyboard layout, click the name of the keyboard layout you want to use.**

You may have a choice of more than one keyboard layout. (Additional keyboard layouts are available from various sources. You install them by dragging them to the System Folder icon.)

5. **Close the Keyboard control panel.**

Making keyboard shortcuts easier to type

With the system software feature called Sticky Keys, you can type keyboard shortcuts (such as ⌘-S for the Save command) without actually pressing the keys simultaneously.

- **To turn Sticky Keys on or off, press the Shift key five times without moving the mouse.**

With Sticky Keys on, you can type a keyboard shortcut by first pressing the modifier key (⌘, Option, Control, or Shift) and then pressing the character key. An icon in the right end of the menu bar (to the right of the Application menu icon) changes to indicate whether Sticky Keys is on and whether a modifier key has been pressed or locked.

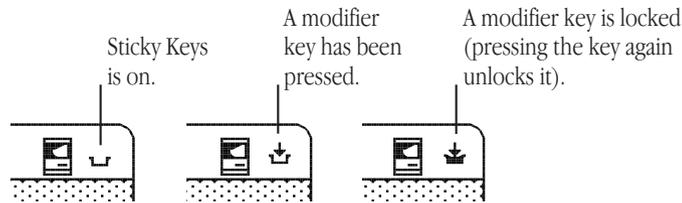

You can have Sticky Keys beep when a modifier key is pressed. You set this option in the Easy Access control panel. Choose Control Panels from the Apple (🍏) menu and open Easy Access.

Adjusting the keyboard for very slow typing

The system software feature called Slow Keys lets you type very slowly and ignores accidental keystrokes by delaying the acceptance of the next keystroke.

- **To turn Slow Keys on or off, hold down the Return key for about four seconds. A beep signals when the feature has been turned on or off.**

You can adjust how long you want Slow Keys to delay acceptance of the next keystroke. You can also set Slow Keys to make an audible click each time a keystroke is accepted. You make these adjustments in the Easy Access control panel. Choose Control Panels from the Apple (🍏) menu and open Easy Access.

Adjusting the blinking of a menu item

You can change the number of times a menu item blinks when it's chosen. You make this adjustment in the General Controls panel.

1. **Choose Control Panels from the Apple (🍏) menu and open the General Controls panel.**
2. **Click the button for the number of times you want the menu item to blink.**

Clicking the Off button prevents a menu item from blinking.

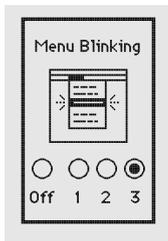

3. **Close the control panel.**

Adjusting the blinking of the insertion point

You can adjust how quickly the insertion point blinks (the insertion point indicates where any text you type will appear). You make this adjustment in the General Controls panel.

1. **Choose Control Panels from the Apple (🍏) menu and open the General Controls panel.**
2. **Click the button for the blinking rate you want.**

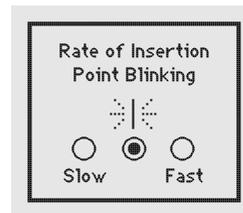

The insertion point in the control panel blinks at the rate you selected.

Changing the way the contents of windows appear

You can change the way the contents of Finder windows are displayed, and you can change the items in the View menu. You make these changes in the Views control panel. Choose Control Panels from the Apple (🍏) menu and open the Views control panel.



Use the Views control panel to change

- the font and font size used in all views (press to open the pop-up menu, then drag to choose a font or a size)
- the arrangement of icons or small icons
- the size of icons used in list views
- what information is included in list views, including folder sizes and the amount of available space on disk

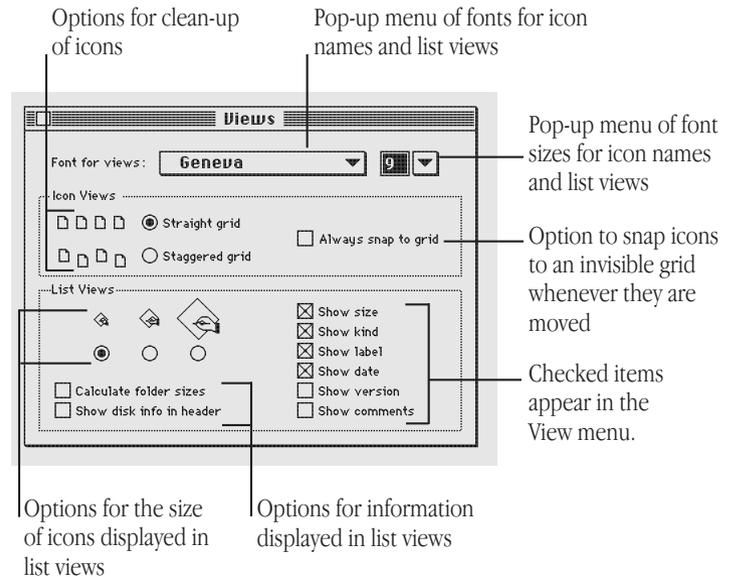

See the summary and shortcuts section near the end of this book for more information about using windows and list views.

Changing an icon

You can change an icon by creating or copying a picture you want and then pasting it into an icon's Info window.

Some icons can't be changed, including those for control panels and other parts of the system software. Every icon fits inside a small square.

1. Select the picture you want to use for the icon.



2. Copy the picture by choosing Copy from the Edit menu.
3. Switch to the Finder, then click to select an icon you want to change.
4. Choose Get Info from the File menu.
5. Click the icon at the upper-left corner of the Info window to select it.

A box appears around the icon when it's selected. If no box appears when you click, the icon can't be changed.



continues ►

6. Choose Paste from the Edit menu.

The picture you copied replaces the selected icon in the Info window. If the picture is bigger than the icon, it automatically shrinks to fit.



7. Close the Info window.

You can restore the original icon by clicking the picture in the upper-left corner of the Info window and choosing Cut from the Edit menu.

Turning off the Empty Trash warning

When you choose Empty Trash from the Special menu, a message warns you that you will not be able to recover the contents of the Trash once it's emptied. (The warning helps you avoid throwing away items unintentionally.)

You can turn off this warning in the Trash's Info box.

1. **Click the Trash icon to select it.**
2. **Choose Get Info from the File menu.**
3. **Click the checkbox labeled “Warn before emptying” to remove the X.**

To turn the warning back on, click the checkbox so that an X appears.

You can also override the warning by holding down the Option key when you choose the Empty Trash command.

Until you choose Empty Trash, items in the Trash continue to occupy space on your disk.

Managing memory

Occasionally you may need to make adjustments in how your Macintosh uses its random-access memory (RAM) in order to work efficiently with large programs or with several programs at once.

Checking memory use

You can find out how much memory your computer has, how much of it is available, and how much memory is being used by each program you have open. You find this information by making the Finder the active program and choosing About This Macintosh from the Apple menu.

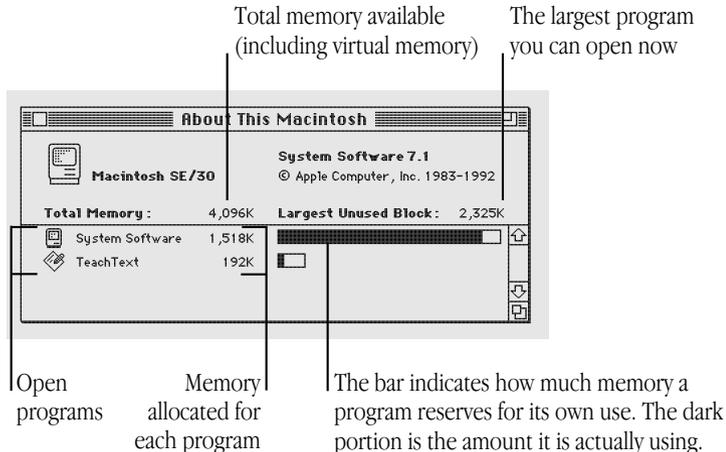

Making the most of your memory

Remember the following tips on memory management:

- Closing a document window does not quit the program. The program remains open and uses memory until you choose Quit from the File menu. (The Application menu, at the right end of the menu bar, shows which programs are open.)
- If you have opened and quit several programs, your computer's memory may be fragmented and you may not be able to open a program that requires a lot of memory. To solve this problem, you can restart your computer.
- If you're not using network services (such as electronic mail or a shared printer), you can make more memory available by turning off AppleTalk in the Chooser and restarting your computer.
- If you're not sharing files over a network, you can make more memory available by turning off file sharing. (See the chapter on networking for more information.)
- Removing system extensions you don't need makes memory available (for example, you don't need the AppleShare extension if your computer will never be on a network and you don't use AppleTalk Remote Access).

continues ►

- Reducing the size of the disk cache makes more memory available. (See the disk cache section in this chapter.)
- Reducing the amount of memory a program uses may allow you to open more programs at once (see the chapter on setting up your programs).

Adjusting the disk cache

The disk cache is memory set aside to help programs work more quickly and efficiently. But the memory in the disk cache is not available for opening programs or documents. If you often want to open more programs than memory allows, you can set the disk cache to a smaller size.

You set the size of the disk cache in the Memory control panel.

1. **Choose Control Panels from the Apple (🍏) menu and open the Memory control panel.**



2. **Click the up or down arrows next to the Cache Size box.**

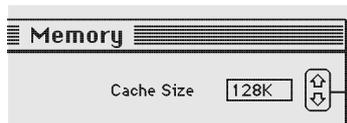

Arrows adjust cache in preset amounts.

3. **Choose Restart from the Special menu.**

Using hard disk space as memory

Your computer can use space on a hard disk to increase the memory available for opening programs. The disk space, called virtual memory, is not available for storing files.

Your computer should contain enough built-in memory for your regular needs—that is, for the programs you frequently have open simultaneously. You can use virtual memory when you want to open additional programs or work with extremely large documents.

Virtual memory is most effective when you are using several small programs simultaneously. It slows the computer's performance if you're using one very large program.

You adjust the use of virtual memory in the Memory control panel.

- 1. Choose Control Panels from the Apple (🍏) menu and open the Memory control panel.**

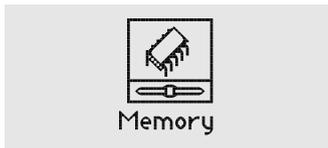

- 2. Click the On button to turn on virtual memory.**
- 3. Press the pop-up menu and drag to choose a hard disk to use for virtual memory.**
- 4. Click the up and down arrows to set the amount of disk space to be used as virtual memory.**

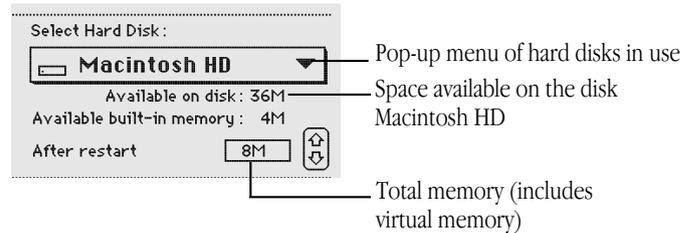

The preset amount is equal to the amount of RAM installed in your computer. Choosing a larger amount of virtual memory is likely to slow the computer's performance, so it is recommended that you accept the preset size.

continues ►

5. Choose Restart from the Special menu.

After you restart, your computer's total memory includes the virtual memory you set aside on the hard disk. Choose About This Macintosh from the Apple (🍏) menu to see memory use information.

△ **Important:** When you turn on virtual memory, the system software creates a file named VM Storage in your System Folder (if the startup disk is used for virtual memory) or on the desktop (if another hard disk is used for virtual memory). This file is large—the size of the computer's RAM and the selected amount of virtual memory combined. For example, if your computer has 4 MB of RAM and you add 2 MB of virtual memory, the VM Storage file will occupy 6 MB of space on your startup disk. △

Turning on 32-bit addressing

Your computer can use very large amounts of memory (more than 8 megabytes) by taking advantage of a feature called 32-bit addressing—the use of very long (32-digit) binary numbers to control the way data is manipulated.

You can turn 32-bit addressing on or off in the Memory control panel.

1. **Choose Control Panels from the Apple (🍏) menu and open the Memory control panel.**

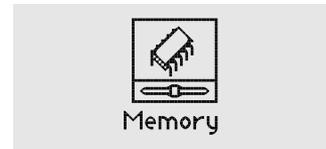

2. **Click the appropriate buttons in the control panel.**

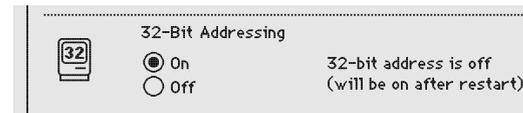

3. **Choose Restart from the Special menu.**

Setting the beep sound

Many programs have the computer make a sound when your attention is required or when you're attempting an action that the computer cannot perform at that time.

You can choose the type of beep sound that you want your computer to make. You can also set the sound's volume.

1. **Choose Control Panels from the Apple (🍏) menu.**
2. **Open the Sound control panel.**



The Sound control panel appears. The beep that your computer is currently using is already selected.

3. **Click the beep sound that you want your computer to use.**

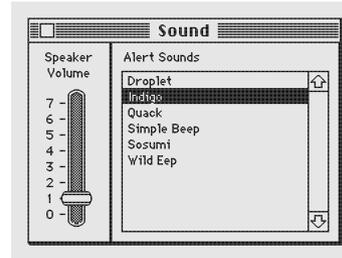

When you click a sound to select it, it's played at the current volume setting.

4. **Drag the slider up or down to set the volume.**

If you set the volume to zero, instead of hearing a beep, you'll see the menu bar flash.

5. **Close the Sound control panel.**

Installing a sound

Your computer comes with several beep sounds. You can get additional sounds from various sources.

- **To install a sound, you drag its icon to the System Folder icon (not the System Folder window).**

The sound is automatically installed in the System file, where it belongs.



Once you add a sound to the System file, it is listed in the Sound control panel.

Removing a sound

You can remove sounds in the Sound control panel. Make sure you have a backup copy of the sounds on floppy disk. (To copy a sound, you can open the System file to see its icon.)

1. **Choose Control Panels from the Apple (🍏) menu.**
2. **Open the Sound control panel.**
3. **Click to select the sound you want to remove.**
4. **Choose Cut from the Edit menu.**

If you selected the wrong sound, you can choose Paste to restore the sound.

5. **Close the Sound control panel.**

You can also remove a sound by opening the System file and dragging the sound's icon out of the System file and out of the System Folder.

Recording sounds

Your computer can use an external microphone, which you can use to record a sound and add it to the Sound control panel.

1. **Connect a microphone or another audio source to the sound input port (marked with the icon ) on your computer .**

For more information, see the chapter on expanding your computer system.

2. **Choose Control Panels from the Apple () menu.**
3. **Open the Sound control panel.**

The Sound control panel appears. The icons of the available sound input devices appear near the bottom of the window.

4. **Click the icon of the sound input device you want to use.**

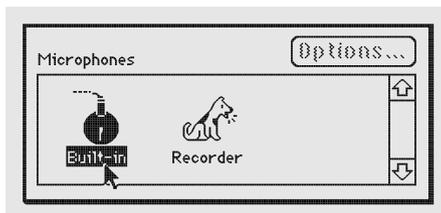

5. **Click the Add button.**
6. **Get ready to record, then click the Record button.**

Recording begins immediately. You have ten seconds to record your sound.

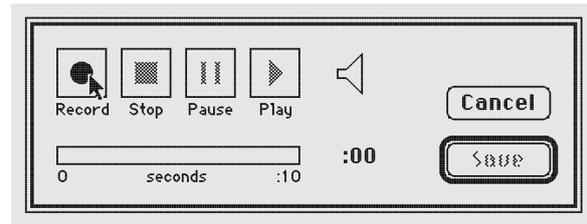

7. **Click Stop to stop recording.**
8. **To listen to the sound you recorded, click Play.**
9. **To save the sound you recorded, click Save.**

continues ►

10. Type a name for the sound, and click OK.

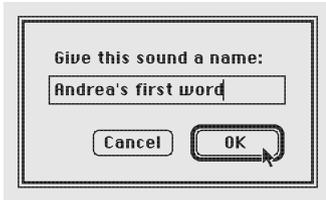

The new sound appears in the Sound control panel. Its icon also appears in the System file.

Changing the background pattern

You can change the background pattern that appears on your computer screen in the General Controls panel.

1. Choose Control Panels from the Apple (🍏) menu and open the General Controls panel.

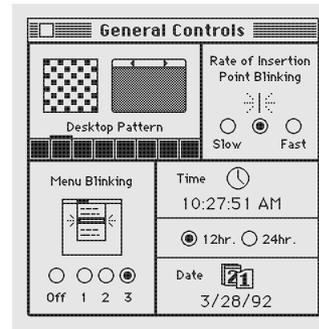

You can choose from a variety of patterns provided, or you can create your own design by editing one of the patterns supplied.

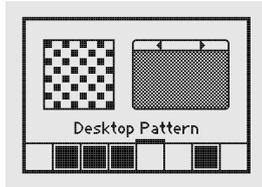

3. To see the patterns available, click either of the small triangles above the sample pattern.
4. Click the sample pattern to see the new pattern on your desktop.

5. To edit a pattern, click in the pattern editing area to the left of the sample pattern.

Each dot in the square changes from white to black (or black to white) when you click it. Your changes are displayed in the sample pattern.

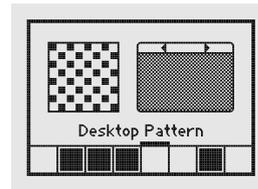

continues ►

6. **When you've finished creating your new pattern, click the sample pattern to display it on your desktop.**
7. **To save the new pattern, double-click the sample pattern.**

If you don't save the pattern, you lose it when you click one of the small triangles to display another pattern.

8. **Close the control panel.**

Magnifying the screen image

The CloseView control panel lets you magnify the image on your computer screen up to sixteen times. It is supplied as part of your system software.

CloseView is not installed when you first start up your PowerBook. It is in a folder called Extras located on your hard disk.

To install CloseView:

1. **Double-click the Extras folder to open it.**

2. Locate the CloseView control panel.

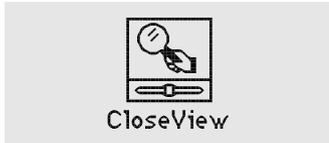

3. Drag the CloseView icon to the System Folder icon (not the System Folder window) on your startup disk.

4. Choose Restart from the Special menu.

To turn CloseView on or off, press ⌘-Option-O.

To turn the magnification on or off, press ⌘-Option-X. (When CloseView is on and the magnification is off, a rectangle on the screen indicates which area will be magnified. You can move the rectangle by moving the pointer.)

To increase or decrease magnification, press ⌘-Option-Up Arrow or ⌘-Option-Down Arrow.

You can set additional options in the CloseView control panel. Choose Control Panels from the Apple (🍏) menu and open the CloseView control panel.

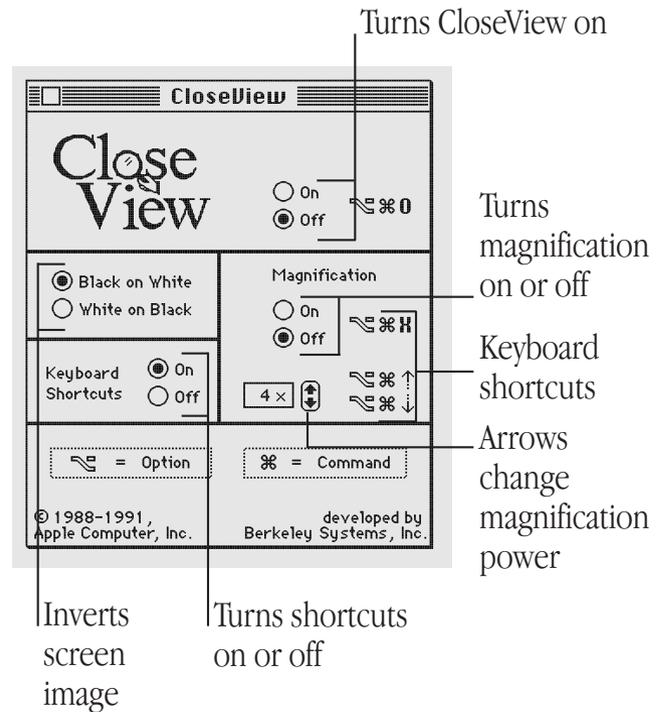

Chapter 11

Printing

In this chapter

- Before you print
- Printing your work
- Controlling background printing
- Working with fonts

Before you print

Before you can print, your computer must be connected to a printer, either directly or over a network. See the information that came with your printer for instructions on how to connect it, or check with your network administrator.

Choosing a printer

Once your printer is connected, you must tell your computer which printer to use by choosing that printer. You need to do this even if only one printer is connected to your computer. You choose a printer when you're using it for the first time and whenever you change printers.

You choose the printer in a program called the Chooser. How you use the Chooser depends on whether your printer is connected directly or over a network.

If your printer is connected directly to your computer

Make sure you've connected the printer according to the instructions that came with it.

1. Choose Chooser from the Apple (🍏) menu.
2. Click the icon of your printer to select it.

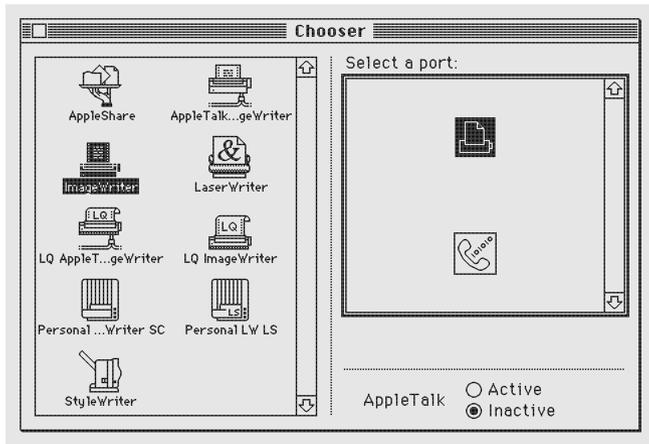

- ❖ *If your printer's icon does not appear in the Chooser:* The printer software is not in your System Folder. Close the Chooser and install the software you need. Consult the documentation that came with your printer for instructions on installing its software. ❖

If you have a Personal LaserWriter SC, you're finished. Close the Chooser now.

3. Click the icon of the port to which your printer is connected.

If your printer is connected to the computer's modem port (marked with the icon 📠), you're finished. Close the Chooser now.

If your printer is connected to the computer's printer port (marked with the icon 🖨️), continue with step 4.

4. Click the Inactive button next to the word "AppleTalk."

If Inactive wasn't already selected, a message appears. Click OK.

5. Close the Chooser window.

If your printer is connected over a network

Ask your network administrator or the person who set up your computer to tell you

- which printer you can use
- which zone it's in (if the network has zones)
- what its name is (every printer on a network has its own name)

1. Choose Chooser from the Apple (🍏) menu.
2. Click the Active button next to the word “AppleTalk.”

If Active wasn't already selected, a message appears. Click OK.

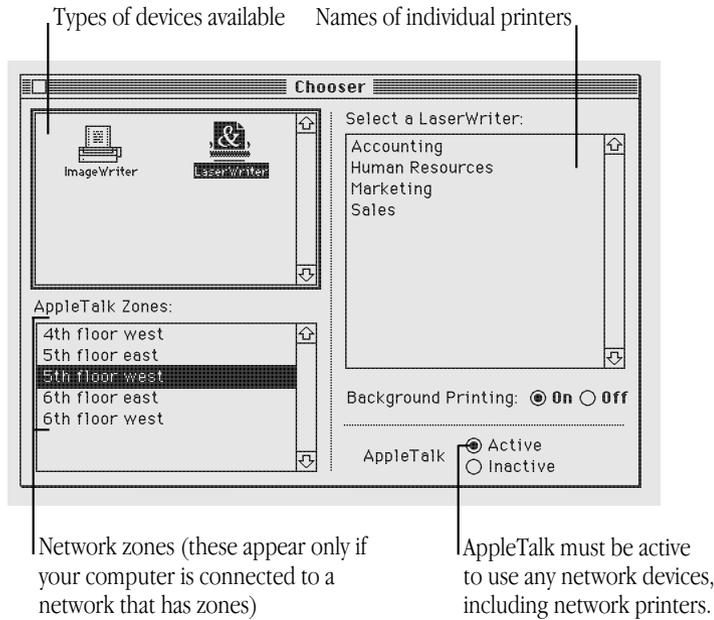

3. Click the icon of the printer you want to use.

❖ *If your printer's icon does not appear in the Chooser:*
The printer software is not in your System Folder. Close the Chooser and install the software you need. See the documentation that came with your printer, or consult the network administrator. ❖

4. If the Chooser lists AppleTalk zones, click the zone where the printer is located.

Zones are listed alphabetically. You can also type to select a zone.

5. Click the name of the printer you want to use (even if only one name appears).
6. If you want to continue using your computer while your documents are being printed, click the On button next to Background Printing.

Background printing is not available with all printers. If it's not available, these buttons do not appear.

7. Close the Chooser.

Selecting Page Setup options

You use the Page Setup dialog box when you've selected a new printer in the Chooser, or when you want to use a different paper size or printing options.

- Choose Page Setup from the File menu and select the options you want.

When a LaserWriter printer is selected, this or a similar Page Setup dialog box appears:

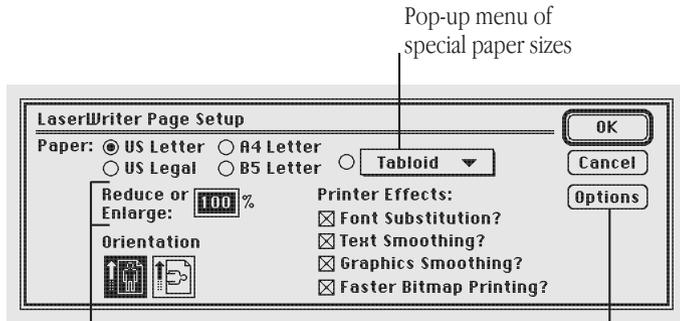

Printed copy as a percentage of the original's size

Click to open a dialog box where you can select enhancements to the printed image.

When an ImageWriter printer is selected, this Page Setup dialog box appears:

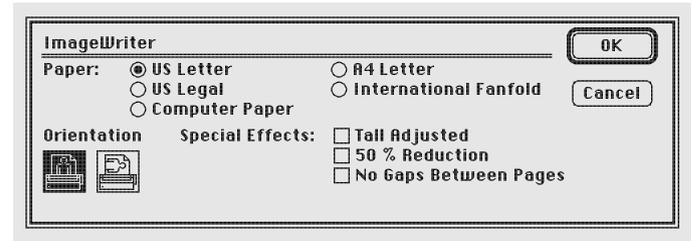

Each type of printer offers different options. Some programs provide additional options. You can choose Show Balloons from the Help menu and then point to options to see descriptions, or check your printer or program manual for details.

Updating printer software on networked computers

All computers that share printers on a network must have the same version of the printer software. The printer restarts itself each time a different version is used (which takes time and clears any fonts from its temporary memory).

△ **Important:** All computers on a network must have the same printer software versions in the System Folder. △

You or your network administrator should update the printer software on all Macintosh computers on the network. You do not have to update any files other than the printer software.

To update printer software, use the Installer program and the accompanying Printer Update document that came with your printer or system software upgrade. If you are installing system software over the network, locate and open the Installer program. If you purchased a system software update kit, the Installer will be on one of the disks.

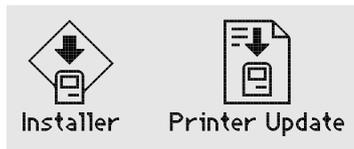

1. **Locate the Installer and Printer Update files, and then open the Installer icon.**

2. **Click OK.**

The Easy Install dialog box appears.

3. **Make sure that the hard disk indicated is the correct one.**

Click the Switch Disk button until the correct disk name appears.

4. **If you want to install software for additional printers, click the Customize button, and then select the names of the printers you want to install software for.**

continues ►

If you want to update the printer software that is already installed on your disk, go to step 5.

When you click Customize, the custom installation dialog box shows a list of printer software.

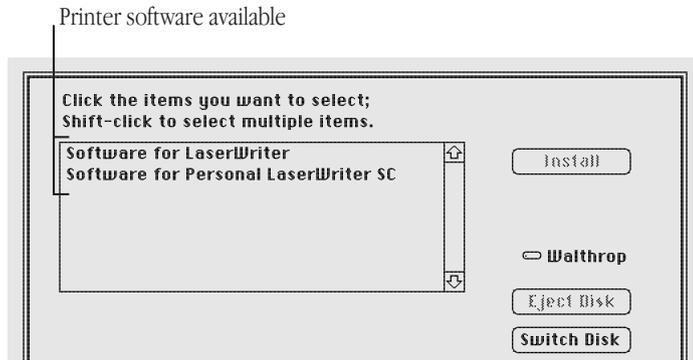

5. Click Install.

6. When you see a message reporting that installation was successful, click Restart.

If a message reports that installation was not successful, try again.

Printing your work

You can print a document while it's open and its window is active; you can also print documents while the Finder is active.

1. Make sure that the document you want to print is in the active window.

If you're printing in the Finder, select the documents you want to print.

2. Choose Print from the File menu.

The printing options that appear depend on the selected printer and the program in which the document was created.

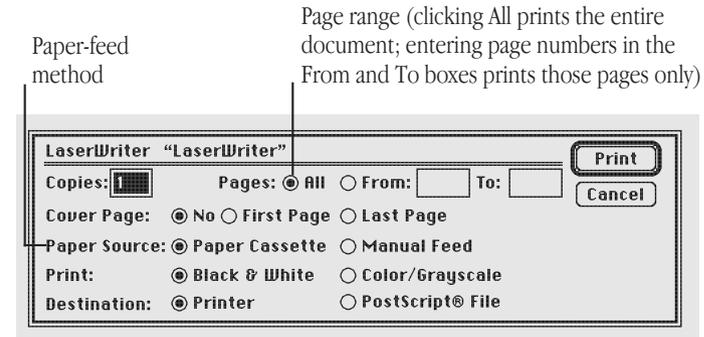

- ❖ *Printing color or gray-scale documents:* You can print color or gray-scale documents on any color printer that can use the LaserWriter printer software. If you print a color document on a black-and-white printer, the document is produced as a halftone (that is, it is composed of patterns of dots). ❖

Some programs offer additional printing options. See the manuals that came with your programs for more information on their printing features.

3. **Click Print.**

A status message appears. If background printing is turned on, the message disappears after a few seconds, and you can do other work while printing continues. Instructions on controlling background printing are in this chapter.

Printing the contents of a window or the desktop

You can print a list of the contents of the active window when you're working in the Finder.

1. **Make sure that the window whose contents you want to print is active.**
2. **Choose Print Window from the File menu.**
3. **Select the options you want.**
4. **Click Print.**

The window's contents are printed, including items not visible on the screen.

When no window is active, you can print the items on the desktop by choosing Print Desktop from the File menu.

Solutions to common printing problems

If nothing happens or if you see an error message when you try to print, try the following:

- Make sure that the printer is turned on and warmed up.
- Check the cable connections to the printer.
- If your printer is an ImageWriter, make sure that the Select light is on. (If not, press the Select button.)
- Make sure that the printer has paper and that the paper is feeding properly.
- Make sure that a printer (and its name or port) is selected in the Chooser.
- If you're on a network, make sure that you are using the same version of the printer software as everyone else.
- If an error message states that the printer could not print your document, turn off the printer for at least 10 seconds. Then turn it on again, wait for the printer to warm up, and try to print again.

If fonts printed on a laser printer look jagged or if lines or letters are missing, your computer may not have enough memory available to print your document properly, the font may not be available in your printer, or the font substitution option may be turned off in the Page Setup dialog box. Try the following:

- Make sure font substitution is turned on in the Page Setup dialog box.
- With background printing turned on, quit the program you're using immediately after you choose the Print command.
- Transfer the fonts you need to your printer (see the section on transferring fonts in this chapter).
- Make use of fewer fonts and sizes in your document.

Controlling background printing

If you are using a LaserWriter or StyleWriter printer and the background printing option is turned on in the Chooser, you can continue to work while your documents are printing.

You don't need to do anything once background printing is turned on. But if you wish, you can control background printing with PrintMonitor, a program that's part of system software.

1. After you have started printing a document, choose **PrintMonitor** from the **Application** menu.

A few moments after printing begins, PrintMonitor opens automatically and its name appears in the Application menu.

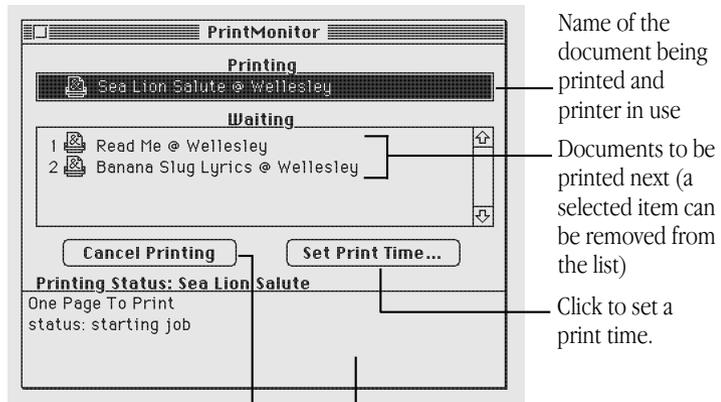

Click to stop printing the current document.

Description and status of the current printing job appear here.

Name of the document being printed and printer in use

Documents to be printed next (a selected item can be removed from the list)

Click to set a print time.

You can use PrintMonitor to

- check the printing of your document
- cancel a document that's printing or waiting to print
- set the date and time you want a document to print or postpone printing indefinitely
- check the paper supply

PrintMonitor's icon blinks at the right end of the menu bar when the printer is out of paper. You can change this alert signal with the Preferences command in the File menu.

- check when to feed paper manually

PrintMonitor's icon blinks at the right end of the menu bar to signal that you must confirm manual printing. You can change this alert signal with the Preferences command in the File menu.

2. Select the options you want, and then close the **PrintMonitor** window.

Working with fonts

A font is a collection of letters, numbers, and symbols in a distinctive typographic design.

Several fonts come with your computer's system software. They are stored in the Fonts folder (inside the System Folder on your startup disk). You can install additional fonts and remove fonts.

Additional fonts are supplied in the Extras folder on your hard disk.

Outline fonts and bitmap fonts

The Macintosh uses two types of fonts:

- outline fonts
- bitmap fonts

Both types of fonts are installed in your System file when you install system software.

Outline fonts (also called scalable or variable-size fonts) can appear at any size, because each character is described as a mathematical formula that adjusts according to the size you want.

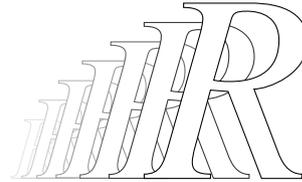

Your computer needs only a single outline font in a particular typeface (such as Courier) to display or print that typeface in any size. The outline fonts supplied with Macintosh system software are called TrueType fonts.



Bitmap fonts (also called fixed-size fonts) appear only in certain sizes, because each character is a grid of black-and-white dots (called a bitmap), which is a rendering of the character's shape in a specific size.

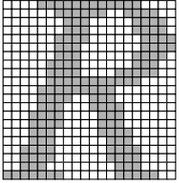

For the best type quality when using bitmap fonts, your computer needs a separate bitmap font in each size you want to display or print, such as 12-point Times or 9-point Monaco.



Installing fonts

1. **Quit all open programs.**
2. **Locate the font you want to install, and drag it to the System Folder icon (not the System Folder window) on your startup disk.**

Fonts are supplied either as individual files (for individual fonts) or in suitcases (for font families). To install an entire font family, drag its suitcase to the System Folder. If you want to install an individual font within a family, open the appropriate suitcase to see the individual font files.

A message lets you know that the font will be stored in the Fonts folder.

3. **Click OK.**

Removing fonts

1. **Quit all open programs.**
2. **Open the System folder on your startup disk.**
3. **Locate the Fonts folder and open it.**

The Fonts folder contains font files (for individual fonts) and font suitcases (for font families). If you want to remove an individual font within a family, open the appropriate suitcase to see the individual font files.

4. **Locate the font you want to remove, and drag it out of the Fonts folder window and out of the System Folder window.**
5. **Close the Fonts folder window and the System Folder window.**

Transferring fonts to a LaserWriter printer

If you're using a LaserWriter printer equipped with PostScript and you want to print with PostScript fonts that are not built into your printer, you can transfer, or download, those fonts from your System Folder to the printer. Downloading fonts saves printing time if you plan to print several documents that use those fonts.

When you download a font, it's stored in the printer's memory or on a hard disk attached to the printer. You can download as many fonts as the printer's memory and hard disk space allow.

You download fonts with the LaserWriter Font Utility, which is supplied on your hard disk.

1. **Locate and open the LaserWriter Font Utility icon.**



2. Choose Download Fonts from the File menu.
3. If the font you want to download is not listed, click the Add button to add fonts to the list.

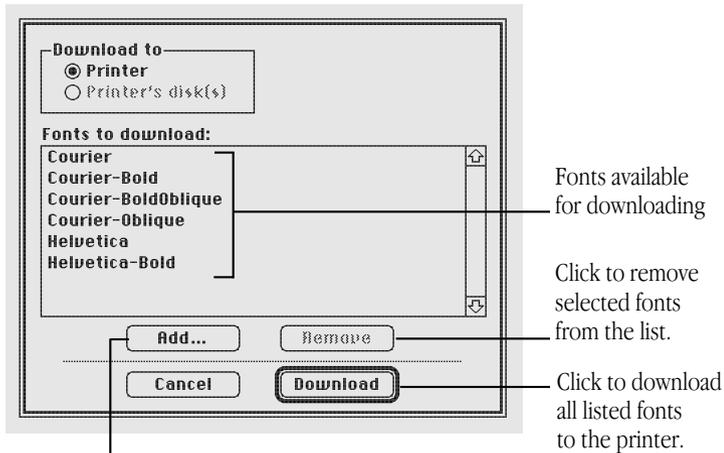

Click to display a directory dialog box for locating and selecting additional fonts.

Use the directory dialog box that appears to locate the fonts you want.

4. In the directory dialog box, locate your font, click its name, and then click Add.

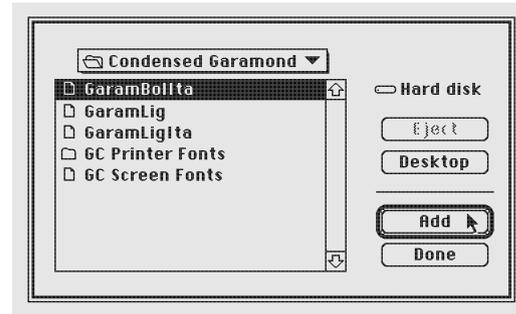

5. When you've added all the fonts you want to download, click Done.

The fonts you added are listed in the Font Utility dialog box.

6. Click Download to send all the fonts in the list to the printer or its hard disk.
7. Click OK when downloading is finished.
8. Choose Quit from the File menu.

Finding out about available fonts

Many programs have a Font menu that lists the fonts installed in your system, though some programs do not list them all. You can open the Fonts folder, inside the System Folder, to see all the fonts stored there. You can also see available fonts with the Key Caps desk accessory in the Apple (🍏) menu.

The LaserWriter Font Utility program (supplied with the system software disks) provides three ways to see the fonts available for printing on a LaserWriter: you can display a list of fonts on the screen, print a font catalog, or print a set of font samples.

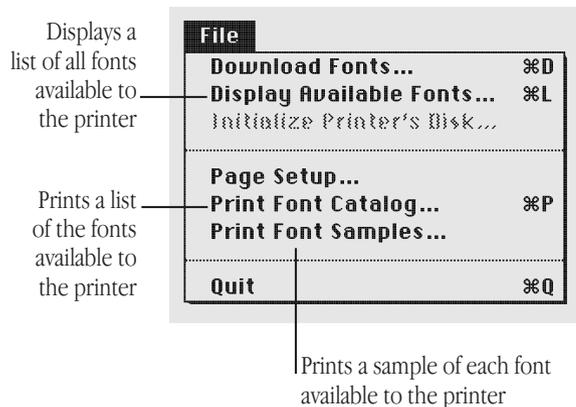

Other ways to use the LaserWriter Font Utility

You can also use the LaserWriter Font Utility program to

- initialize a hard disk attached to a printer
- control whether a start page is printed
- restart a printer
- send PostScript files to a printer

Initializing a hard disk attached to a printer

You can attach a hard disk to some printers. A hard disk allows you to store more fonts. See the manual that came with your printer for information about connecting a hard disk.

1. **Make sure the correct printer is selected in the Chooser.**
2. **Open the LaserWriter Font Utility icon.**
3. **Choose Initialize Printer's Disk from the File menu.**
4. **Click the Drive button until you see the name of the hard disk you want to initialize.**
5. **Click Initialize.**

Initializing erases any information that was on the hard disk.

Restarting a LaserWriter printer

Restarting the printer clears its memory, removing the fonts stored there.

1. **Open the LaserWriter Font Utility icon.**
2. **Choose Restart Printer from the Utilities menu.**
3. **Click Restart.**

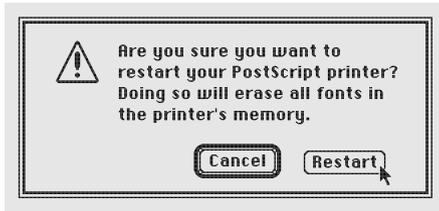

Turning the printer's start page on or off

The LaserWriter can print a start page each time it is turned on or restarted.

1. **Open the LaserWriter Font Utility icon.**
2. **Choose Start Page Options from the Utilities menu.**
3. **Click the On or Off button.**

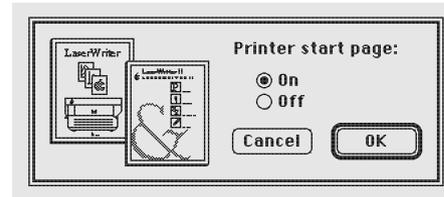

4. **Click OK.**

Transferring a PostScript file to a LaserWriter

You can use the LaserWriter Font Utility to send a file in PostScript format to a LaserWriter printer.

1. **Open the LaserWriter Font Utility icon.**
2. **Choose Download PostScript File from the Utilities menu.**
3. **Click the name of the file you want to download to the printer, and then click Open.**

A dialog box asks you to save a file that will contain a record of the PostScript activity.

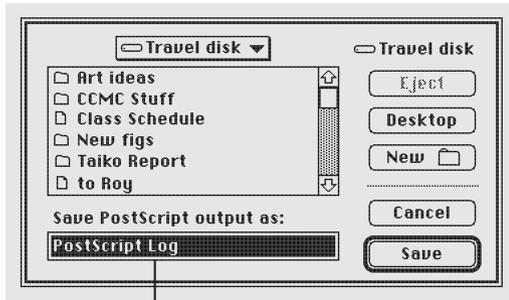

The name of a log that records PostScript activity

4. **Type a name for the log, and then click Save.**

The file is sent to the printer and a record of the PostScript activity is saved in the log.

You can open the log to see the sequence of PostScript commands when the file was sent.

Chapter 12

Using Your Computer on a Network

In this chapter

- What networking offers
- Setting up your Macintosh on a network
- Gaining access to files on shared disks
- Working with files and folders on other computers
- Sharing your own files
- Using access privileges
- Linking programs

What networking offers

When your computer is connected to a network, you can:

- Gain access to information on other computers.

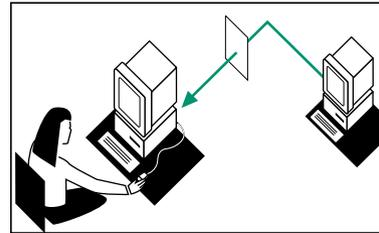

- Allow others access to information on your own computer.

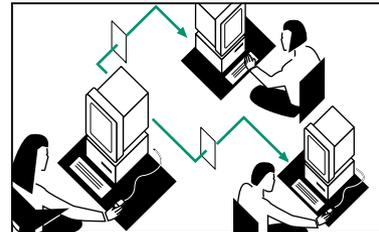

You can designate specific folders and hard disks on your computer as “shared files” that other people can gain access to.

- Print documents on network printers.

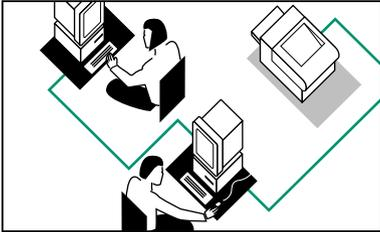

- Link your programs to programs on other computers.

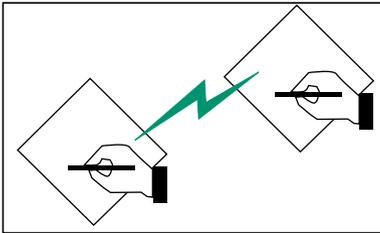

You can link your programs in order to share features between those programs.

- Update files over the network automatically.

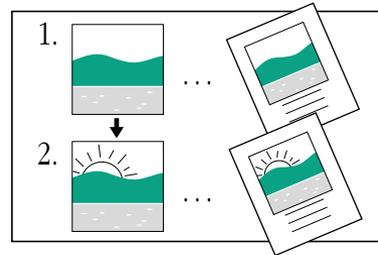

You can automatically update documents created in programs that use the Macintosh system software’s publish-and-subscribe feature. (See the instructions that came with your programs for information about publish-and-subscribe.)

Setting up your computer on a network

Before you can use your computer on a network, you need to physically connect your computer to the network and install networking software.

If a network administrator manages the network to which you’ll be connecting your computer, ask that person for advice or help.

Connecting to a network

Your computer has built-in AppleTalk networking software. This software directly supports the LocalTalk cables you need to connect your computer to the network. (If your computer has the appropriate port or expansion card, AppleTalk also supports Ethernet and TokenRing cables.)

1. Choose Shut Down from the Special menu.
2. Connect the LocalTalk cable to the printer port (🖨️) on the back of your computer.

If your computer has a combined printer/modem port, connect the LocalTalk cable to that port.

See your network administrator or the documentation that came with your cables if you need more information.

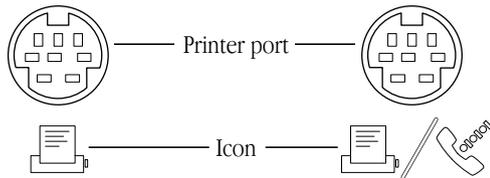

Turning on AppleTalk

The first time you turn on your computer after you have connected it to a network, you need to make sure that AppleTalk is turned on.

1. Choose Chooser from the Apple (🍏) menu.
2. Click the Active button to turn on AppleTalk.

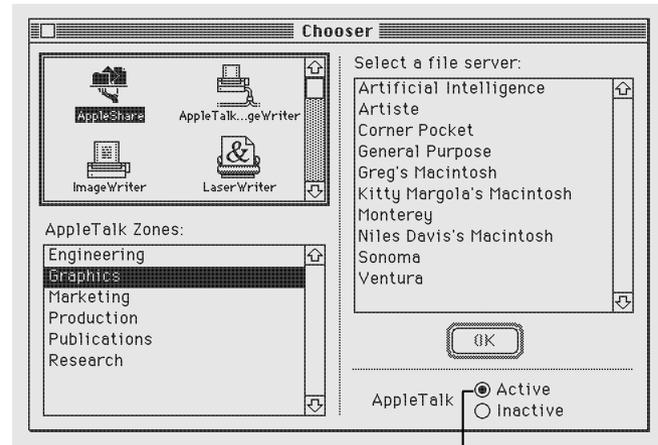

AppleTalk must be active before you can use a network.

continues ▶

3. Close the Chooser.

When AppleTalk is active, Macintosh PowerBook computers go to sleep automatically only when they run out of battery power, or when the power adapter is plugged in and the PowerBook is not connected to any shared disks on the network.

Naming your computer and its owner

Before you use the network, you should give your computer a name and name yourself as its owner.

1. Choose Control Panels from the Apple () menu and open the Sharing Setup icon.



- ❖ *If you can't find or can't open the Sharing Setup icon:* Check whether the Sharing Setup icon is in the Control Panels folder and the File Sharing and Network icons are in the Extensions folder inside the System Folder. ❖

2. Type your name in the box labeled Owner Name and press Tab.

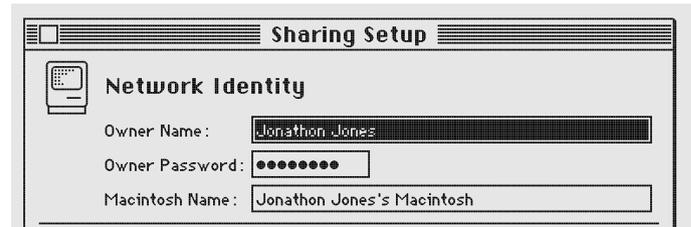

3. Type your password in the box labeled Owner Password and press Tab.

Your password can be up to eight characters long. Remember the capitalization you use. After you press Tab, your password is replaced by bullets (•) so no one can read it.

4. Type a name for your computer in the box labeled Macintosh Name.

This is the name others will see when they access your computer on the network.

5. Close the Sharing Setup control panel.

Gaining access to files on shared disks

You can retrieve and store information on other computers connected to your network. For example, a colleague can place some files for you on a shared disk called a file server—a computer dedicated to storing shared files. Individually owned computers on your network might also have shared disks.

Before you begin

Before you store or retrieve information on the network, do the following:

- Find out the name of the shared disk you want to access and the name of the computer that it's on.
- If your network has zones, find out the name of the zone that computer is in.
- Find out if you are registered on the computer or if it allows guest access.

A computer owner or network administrator can limit access to files on a shared disk. Ask the owner or network administrator what type of access you have to the files.

- If you're a registered user, find out the name and password you need to use.

Find out exactly how your name and password are spelled, including capitalization.

Connecting to a shared disk

1. **Choose Chooser from the Apple () menu.**
2. **Make sure that AppleTalk is active.**
3. **Click the AppleShare icon in the upper-left section of the Chooser window.**

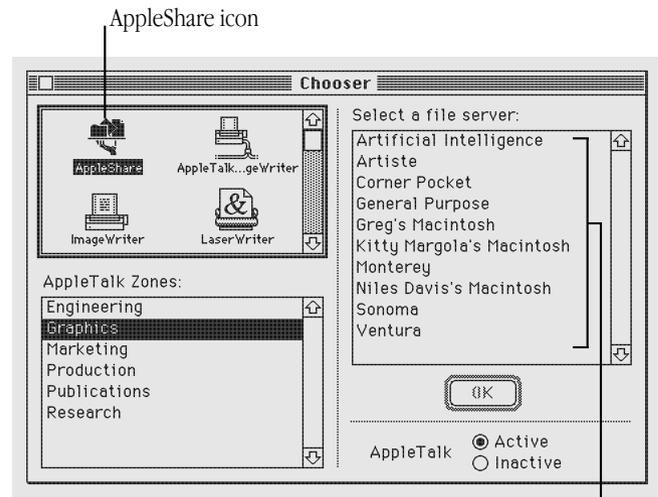

continues ►

❖ *If the AppleShare icon does not appear:* Make sure that AppleTalk is active in the Chooser. Make sure that the AppleShare file is in the Extensions folder in your System Folder, and restart your computer. ❖

4. If you see a box labeled “AppleTalk Zones”, click the zone the computer is in.

Computers with shared disks are listed as file servers on the network.

5. Click the name of the computer you want to use.

If the name you want isn't listed, make sure you have selected the correct zone (if your network has zones), and make sure the other computer is turned on.

6. Click OK.

7. Click Guest or Registered User.

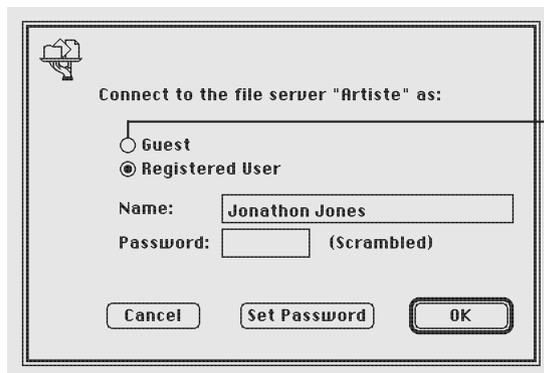

Click here if you are not registered on the computer that you're connecting to.

If you are a guest, click Guest and go to step 10. If the Guest option is dimmed, guests do not have access to this computer.

8. If you are a registered user, make sure the name in the box is correct.

Capitalization does not need to match.

9. Type your password.

Capitalization does need to match.

10. Click OK.

If your password is not accepted: Make sure that Caps Lock is not on. Type your password again, taking care not to make typing errors. If it's still not accepted, ask the computer's owner for help.

11. Click the name of a shared disk to select it.

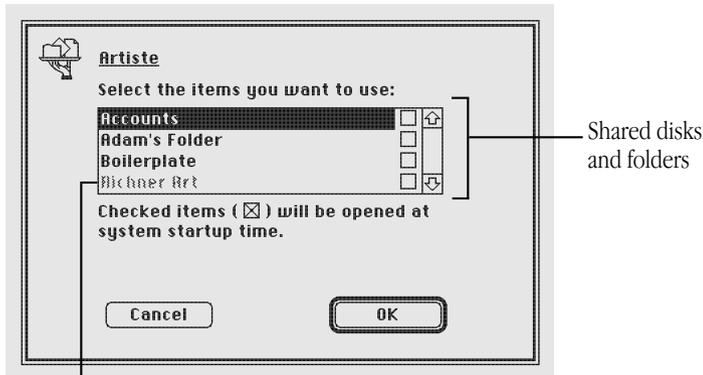

12. Click OK.

The icon of the shared disk appears on your desktop.

13. Close the Chooser.

Disconnecting from a shared disk

When you're finished using a shared disk, close any open files or programs on the shared disk and then disconnect in one of the following ways:

- Select the shared disk icon and choose Put Away from the File menu.
- Drag the shared disk icon to the Trash.
- Choose Shut Down from the Special menu. Shutting down automatically disconnects from the shared disk.

Connecting quickly to a shared disk

By making an alias for a shared disk, you can connect to that disk by simply opening the alias.

1. Connect to a shared disk.

See the section on connecting to a shared disk in this chapter.

2. Select the shared disk icon.

3. Choose Make Alias from the File menu.

4. Put the alias in a convenient location and rename it if you wish.

5. Next time you want to connect to the shared disk, open the alias you created in step 3.

6. If you originally connected to the shared disk as a registered user, a message appears. Type your password.

If you connected to the shared disk as a guest, this message does not appear.

The shared disk icon appears on your desktop.

If the shared disk is on a computer that is turned off, or if there is a problem with the network, you'll see a message.

Connecting automatically when you start up

You can connect automatically to one or more shared disks whenever you turn on your computer.

1. Connect to the computer that has the shared disk you want to open.

See the section on connecting to a shared disk in this chapter.

2. Click the checkbox next to the name of the shared disk.

Click one of these buttons to indicate whether you want to enter your password at startup.

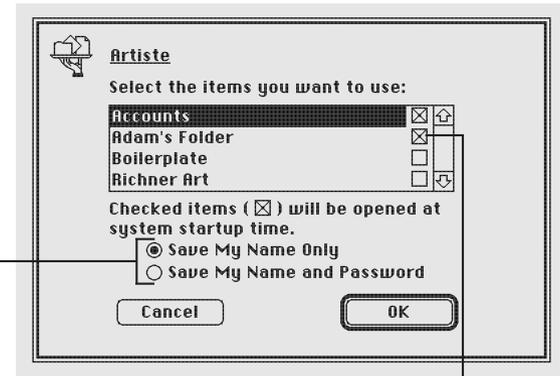

Click a box to connect automatically when you start up your computer.

- 3. If you're connecting as a registered user, click the button that indicates whether you want to save your name only, or both your name and your password.**

For more security, click "Save My Name Only." When you start up your computer, you'll need to enter your password to connect to the shared disk.

- 4. Click OK.**
- 5. Close the Chooser.**

Working with files and folders on other computers

Once you are connected to a shared disk, you can use the files and folders on it as if they were on your own computer.

You may not be able to open some items on a shared disk if the owner has restricted access to those items. For information on how to check your access privileges, see "Working With Privileges That Others Have Set" later in this chapter.

Creating a new folder on another computer

You can create a new folder on a shared disk (as long as you have the correct access privileges). If you are a registered user, you become the owner of any folder that you create. If you are connected as a guest, you share ownership of the folder with all guests and registered users.

The icons of folders that you own on another disk have a darkened tab.



When you own a folder, you can determine who can use it and in what way. See "Using Access Privileges" later in this chapter for more information.

Changing your password

If you are a registered user, you may be able to change the password you use to connect to a shared disk. (Your network administrator can restrict this capability.)

- 1. Connect to the computer that has the shared disk you want.**
- 2. Click the Set Password button.**

continues ►

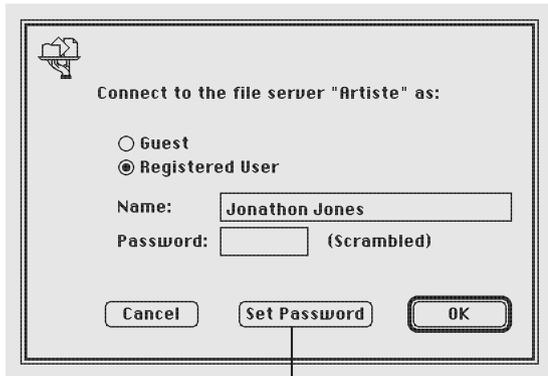

Click here to change your password.

If a message tells you that you cannot change your password, your network administrator has turned off this feature.

3. **Type your current password. Then press Tab and type a new password.**

A bullet (•) appears for each letter you type.



4. **Click OK.**
5. **Click OK in the dialog box that appears.**
6. **Retype your new password and click OK.**

Your new password is now in effect.

Giving folder ownership to someone else

You can give away ownership of any folder you own. Once you do so, however, the new owner can restrict your access to that folder. Make sure you have copies of any files you may need before you give ownership of a folder to someone else.

1. **Connect to a shared disk.**
2. **Click a folder that you own to select it.**
3. **Choose Sharing from the File menu.**
4. **Type the name of a registered user or group in the box labeled Owner.**
5. **Close the Sharing window.**

A message asks you to confirm that you want to change the owner of the folder.

6. **Click OK.**

The user or group that you named assumes ownership immediately.

Sharing your own files

You can share files stored on your computer with others on the network. For example, members of your work group can connect to your computer and open a file from their own computers. (They do not have to be using System 7.) Or, if you have both a desktop Macintosh and a PowerBook computer, you can transfer files from one computer to the other without using floppy disks.

You control what you share and with whom you share it:

- You share only the items you specify.
- You share only with the people you specify—one person, a group of people, or everyone on the network.
- You can see everything on your own computer from another computer on the network.

How file sharing works

There are three steps to sharing a folder or disk:

1. turn on file sharing
2. select a folder or disk to share
3. decide whom to share it with

The folder or disk you share is not accessible to anyone but you until you choose whom to share it with.

Turning file sharing on

1. **Choose Control Panels from the Apple (🍏) menu and open the Sharing Setup icon.**

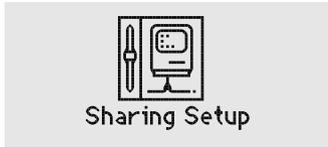

Make sure the boxes in the Network Identity section of the control panel are filled in.

2. **In the section labeled File Sharing, click the Start button.**

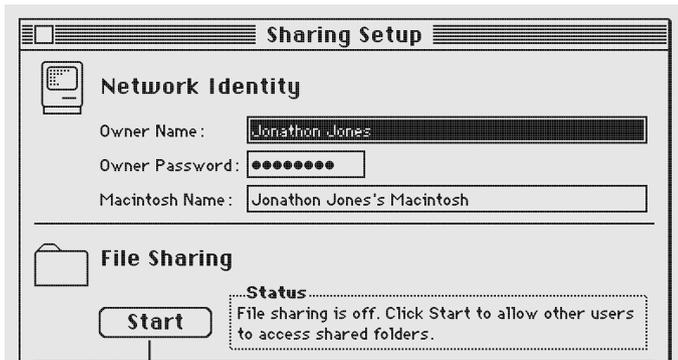

Click here to start file sharing.

3. **Close the Sharing Setup control panel.**

If you want to give everyone on the network access to the items you share, continue with the next section, "Turning On Guest Access."

Turning on guest access

If you want all users connected to the network to have access to your shared folders and disks, you need to turn on guest access.

1. **Choose Control Panels from the Apple (🍏) menu and open the Users & Groups control panel.**



2. **Open the <Guest> icon.**

3. Click the box under File Sharing labeled “Allow guests to connect” to place an X in it.

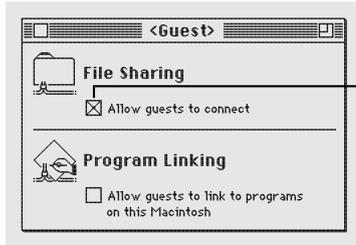

To allow guests to connect to your computer, click here so that an X appears in the box.

4. Close the window and click Save in the box that appears.

You can still restrict access to any folder or disk you share, as described in the section “Using Access Privileges,” later in this chapter.

Continue with the next section to select a folder or disk to share.

Selecting a folder or disk to share

You can share any folder, hard disk, or CD-ROM disc connected to your computer. (You cannot share floppy disks.) You can share up to ten folders or disks at a time. (This number does not include folders within the folders or disks you share.)

1. Make sure file sharing is turned on.
2. Select a folder or disk to share.
3. Choose Sharing from the File menu.
4. Click the box labeled “Share this item and its contents” to place an X in it.

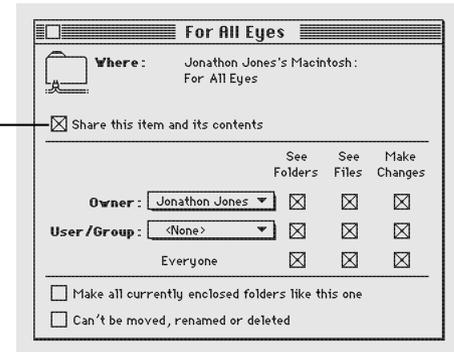

Click here to share the item you've selected.

For information about the other checkboxes in this window, see “Using Access Privileges,” later in this chapter.

5. Close the window and click Save in the dialog box.

At this point, only you have access to the item you shared and the files inside it, unless you turned on guest access and some or all of the boxes next to “Everyone” are checked.

If you haven’t turned on guest access, continue with the section “Naming a Registered User” if you want to name the specific people you want to share the item with. (Even if the checkboxes next to Everyone are selected, you cannot give access to everyone unless you’ve turned on guest access, as described in the previous section.)

If you shared a folder, its icon appears with a darkened tab and network cables:

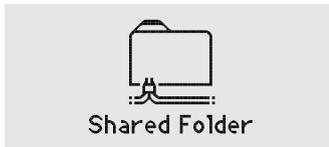

When people on the network are connected to your shared folder, its icon appears with faces in the center:

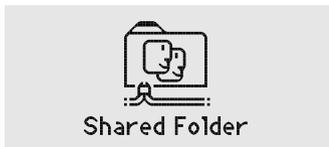

△ **Important:** Before you put programs inside shared folders or disks, remember that copyright laws may prevent those programs from being shared. Check the applicable licensing agreements and follow their specifications. △

Taking back a shared folder or disk

Any shared folder or disk can be made private again.

1. **Select the shared disk icon.**
2. **Choose Sharing from the File menu.**
3. **Click the box labeled “Share this item and its contents” to remove the X.**

If people are connected to your computer, you see a message asking you to confirm your decision.

Naming a registered user

You can register as many as 100 people and groups combined, but for best network performance you should name no more than 50.

1. **Choose Control Panels from the Apple () menu and open the Users & Groups icon.**

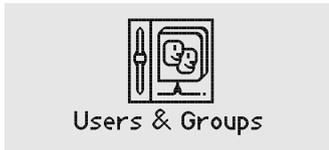

2. **Choose New User from the File menu.**

An icon labeled New User appears. Its name is selected for editing.

- ❖ *If you can't find the New User command:* Make sure the Users & Groups window is active. ❖

3. **Type the name of a person you want to register.**

Make sure you notify the person of the name you type. (Capitalization does not have to match.)

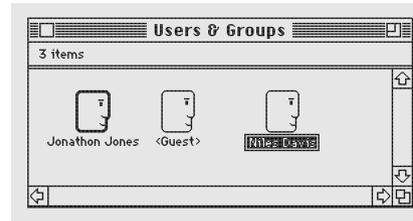

4. **To register more users, repeat steps 2 and 3.**

To assign passwords or to name groups of users, continue with the next two sections. If you want to start sharing immediately, go to “Selecting a User or Group to Share a Folder or Disk,” later in this chapter.

Setting a registered user's password

You can assign passwords for registered users to verify their identities when they want to gain access to your computer.

1. Open a user icon in the Users & Groups control panel.

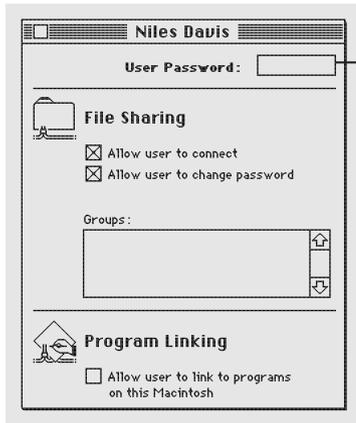

Type the user's password here.

2. Type a password in the User Password box, then press Tab.

The password can be up to eight characters long. When you press Tab, the password is replaced by bullets. Make sure to inform the user of the exact password, *including capitalization*.

3. Close the window, and then click Save in the dialog box.

Naming a group of users

You can name several registered users as a *registered group*.

1. Open the Users & Groups control panel and choose New Group from the File menu.

An icon labeled New Group appears. The name is selected for editing.

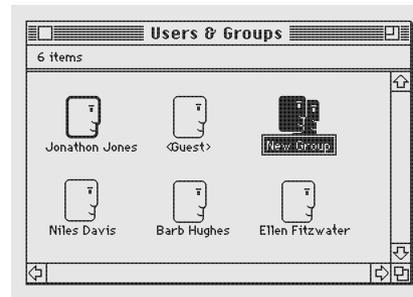

2. Type a name for the group.

3. Drag user icons to the new group icon.

The icons are not moved inside the group icon, as they would be if it were a folder. Instead, member icons are created inside the group icon. You don't need to drag your own icon to the group icon because you (as the owner) have access to the entire contents of your computer (unless you specify otherwise).

You don't need to include the <Guest> icon in any group.

To allow this group access to a shared folder or disk, go to the section "Selecting a User or Group to Share a Folder or Disk."

Seeing who's in a group

- To see the names of all group members, open the group icon.

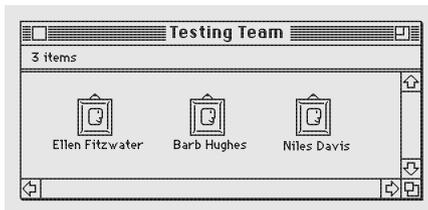

You can open any member icon to see or change the settings you've made for that user.

- To see all the groups that a user belongs to, open the user's member icon or user icon.

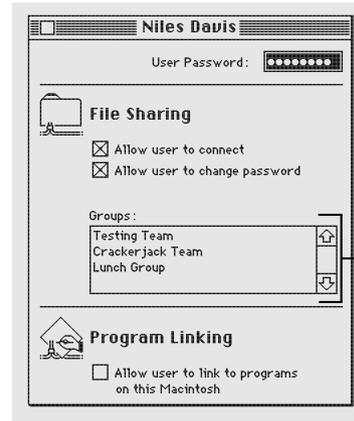

The groups the user belongs to are listed here.

Selecting a user or group to share a folder or disk

You can give one registered user or group exclusive access to a shared folder or disk on your computer.

1. Select a folder or disk to share.
2. Choose Sharing from the File menu.
3. Click the box labeled “Share this item and its contents” so an X appears.
4. Choose a user or group from the User/Group pop-up menu.

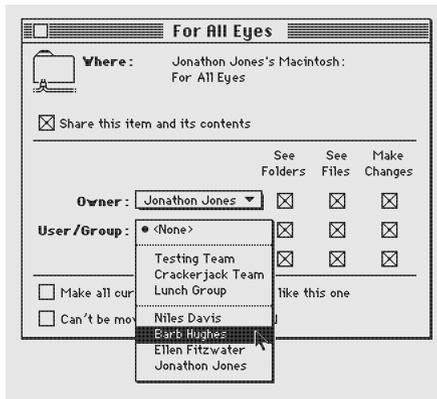

5. To share the item with only the user or group you've chosen, click the bottom row of checkboxes (next to Everyone) to remove the X from each box.

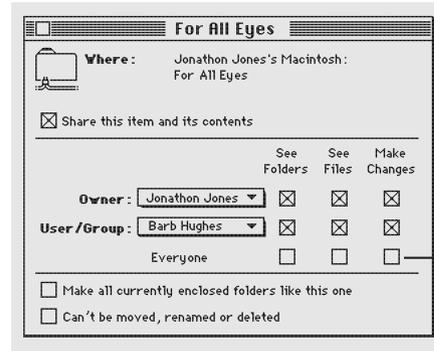

6. Close the window and click Save in the dialog box.

Preventing specific users or guests from accessing your computer

To prevent all network access to your computer, you can turn file sharing and program linking off, as described elsewhere in this chapter.

1. Choose Control Panels from the Apple () menu and open the Users & Groups icon.

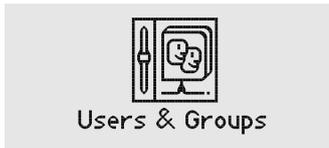

2. To deny access to a specific user, open the user icon.

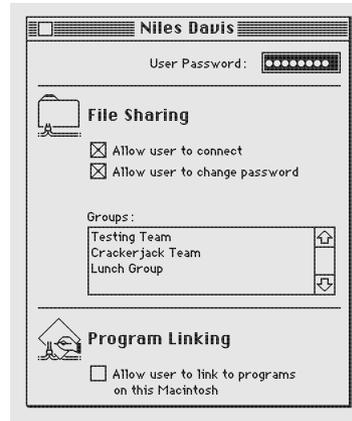

3. To deny access to guests, open the <Guest> icon.

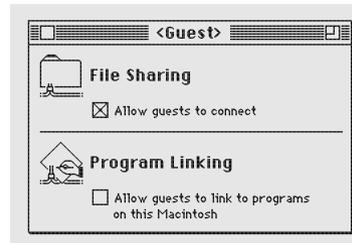

continues ►

4. **If an X appears in the “Allow to connect” checkbox, click to remove the X (to deny access).**
5. **Close the window and click Save in the dialog box.**

If you deny access to a user who is currently connected, he or she is disconnected immediately. That user is no longer a member of any group, and can connect only as a guest.

If you deny access to guests, any guests currently connected are disconnected immediately. Only registered users and groups that you’ve specified will have access to your computer.

Removing a user from a group

1. **In the Users & Groups control panel, open the group icon.**
2. **Drag the member icon for that user to the Trash.**
3. **Choose Empty Trash from the Special menu.**

Removing a user or group from your list of registered users

You can remove a registered user or group at any time. When you remove a user, he or she will no longer be a member of any registered group.

1. **Open the Users & Groups control panel.**
2. **Drag the user icon or group icon to the Trash.**
3. **Choose Empty Trash from the Special menu.**

If the user is currently connected, he or she is disconnected immediately.

You cannot throw away the <Guest> icon or the owner icon.

Giving away ownership of a folder or disk on your computer

You can give away ownership of a shared folder or disk on your computer to a registered user or group.

Because you are the owner of your computer, the new owner of a folder or disk on your computer cannot restrict your access to it. However, the new owner can change the access privileges that other people have to the item. If you give away ownership of a folder or disk, make sure to remove any folders or documents that you don't want others to see or change.

1. **Select a shared folder or disk.**
2. **Choose Sharing from the File menu.**
3. **Choose a name in the Owner pop-up menu.**

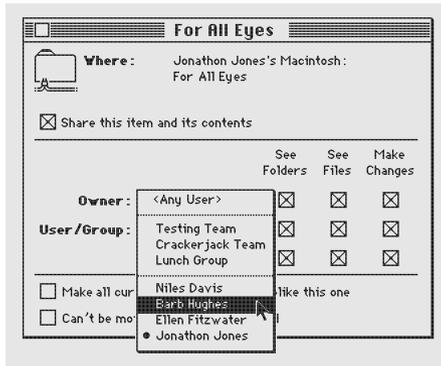

If you select <Any User>, then anyone on the network can change the access privileges or ownership of the item.

4. **Close the window and click Save in the dialog box.**
5. **Click OK to confirm that you want to change ownership.**

Turning file sharing off

You can turn file sharing off at any time. When file sharing is off, people on the network cannot access folders or disks on your computer, and you cannot access your computer from another computer on the network.

When you turn file sharing back on, the items you shared before are available again automatically.

1. **Choose Control Panels from the Apple (⌘) menu and open the Sharing Setup icon.**

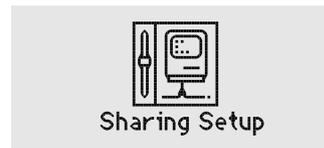

continues ►

2. In the section labeled File Sharing, click the Stop button.

A dialog box appears in which you can specify a delay before file sharing is turned off. If you specify a delay, users who are connected to your computer are warned to save their work and disconnect.

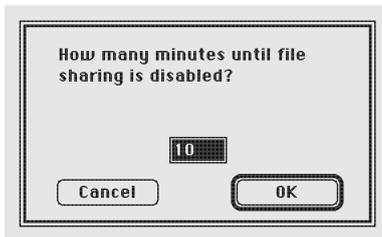

3. Type the number of minutes you want to elapse before file sharing is turned off.

To turn file sharing off immediately, type the number 0.

4. Click OK.

If someone is using files on your Macintosh when file sharing is turned off, any changes he or she has not saved will be lost.

Monitoring file-sharing activity

When file sharing is on, you can see who is connected to your computer and what folders or disks you've shared.

- **Choose Control Panels from the Apple (⏏) menu and open the File Sharing Monitor icon.**

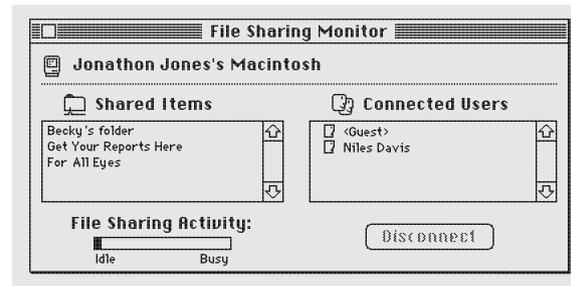

Disconnecting someone who is connected to your computer

You can disconnect users who are currently connected to your computer in the File Sharing Monitor control panel.

1. **Select the user or users you want to disconnect.**
2. **Click Disconnect.**
3. **Type the number of minutes that you want to elapse before users are disconnected.**

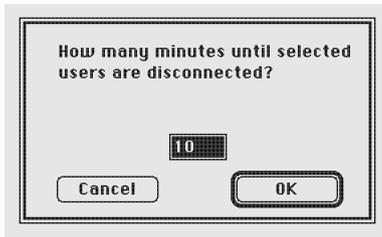

If you specify a delay, users are warned to save their work and disconnect. To disconnect a user immediately, type 0.

4. **Click OK.**

A message remains on the screen until the time is up. You can switch to any program you already have open so you can continue working.

5. **When the designated amount of time has elapsed, close the File Sharing Monitor.**

Gaining access to your computer from another computer

You can connect to your own computer from another computer on the network and access everything on the disks attached to your computer.

1. **Make sure that file sharing is turned on.**
2. **Choose Control Panels from the Apple () menu and open the Users & Groups icon.**



continues ►

3. Open the owner icon (the one with the bold outline).
4. Click the boxes labeled “Allow user to connect” and “Allow user to see entire disk” to place an X in them.

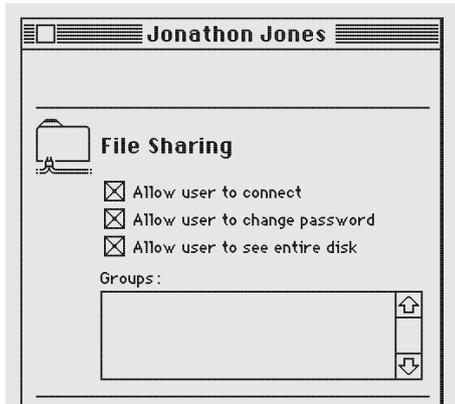

When these boxes are checked, you can see and use everything on your disks while you're using another computer.

To restrict your access, click a checkbox to remove the X.

5. Close the window and the Users & Groups control panel.
6. Leave your computer turned on.

To gain access to your computer, connect to it as a registered user. Type your owner name and password as they appear in the Sharing Setup control panel of your computer. Then connect as you normally would.

- ❖ *If you are unable to connect to your computer:* Make sure that your computer is turned on, that your computer has file sharing turned on, and that you have the correct access privileges. Make sure that you type your password exactly as it is entered in the Sharing Setup control panel, including capitalization. ❖

Changing your password

You can change the password you use to gain access to your own computer from another computer.

1. Choose Control Panels from the Apple (🍏) menu and open the Sharing Setup icon.



2. Type a new password in the box labeled Owner Password and press Tab.

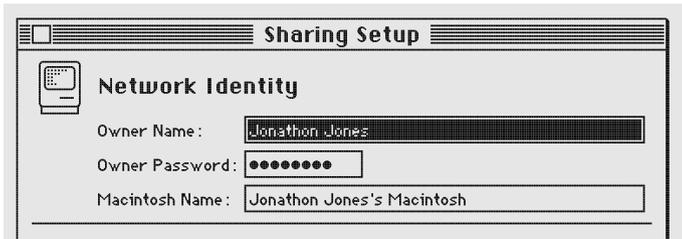

Remember the capitalization. Your password is replaced by bullets to keep it private.

3. Close the Sharing Setup control panel.

Your new password is now in effect.

Using access privileges

Access privileges let you control what other people can do with the information you share on a network. For example, you might want to let people see a file but prevent them from changing it.

Understanding access privileges

You can set access privileges for any shared folders on your own computer and any folders you create on another Macintosh. Owners of other computers can set access privileges that restrict what you can do with their shared disks.

Three categories of people can have access privileges to shared disks and folders:

- **The owner:** The owner of a folder can change the access privileges to that folder. You become the owner of a folder automatically when you create it and you are the owner of any folder on your computer. You can keep ownership or give it away.
- **A registered user or group:** A registered user has special access to shared disks over the network. A registered group is a group of registered users.
- **Everyone:** This category includes the owner, registered users, and guests.

There are three types of access to shared items:

- **See Folders:** allows people to see, open, and copy folders.
- **See Files:** allows people to see, open, and copy files.
- **Make Changes:** allows people to copy, delete, or change the contents of a folder or disk, or to add items to a folder or disk.

The table indicates which privileges you need to see folders, see files, or make changes to items in a shared folder or disk.

Action	See Folders	See Files	Make Changes
Copy or move files to a folder	<input type="checkbox"/>	<input type="checkbox"/>	<input checked="" type="checkbox"/>
Copy a file from a folder	<input type="checkbox"/>	<input checked="" type="checkbox"/>	<input type="checkbox"/>
Copy a folder from a folder	<input checked="" type="checkbox"/>	<input type="checkbox"/>	<input type="checkbox"/>
Create a folder in a folder	<input checked="" type="checkbox"/>	<input type="checkbox"/>	<input checked="" type="checkbox"/>
Delete a file from a folder	<input type="checkbox"/>	<input checked="" type="checkbox"/>	<input checked="" type="checkbox"/>
Delete a folder from a folder	<input checked="" type="checkbox"/>	<input type="checkbox"/>	<input checked="" type="checkbox"/>
Open and use a file in a folder	<input type="checkbox"/>	<input checked="" type="checkbox"/>	<input type="checkbox"/>
Save changes to a file in a folder	<input type="checkbox"/>	<input checked="" type="checkbox"/>	<input checked="" type="checkbox"/>

Setting access privileges to folders and disks

You can set access privileges for shared items on your own computer and for items that you own on other computers.

1. **Select a folder or disk.**
2. **Choose Sharing from the File menu.**

The dialog box you see may be slightly different from the one pictured.

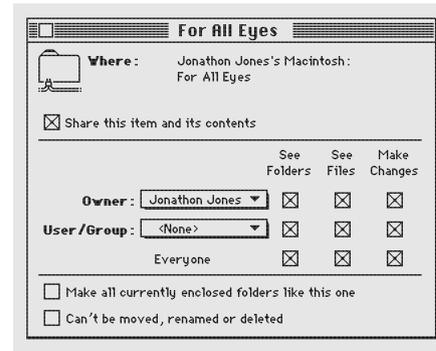

- If you've selected a folder inside a shared folder, the checkbox at the top is labeled "Same as enclosing folder."
- If you've selected a folder on another computer, the Owner and User/Group areas are text boxes, not pop-up menus.

- If you've selected a folder you do not own, all the checkboxes and their labels are dimmed.

3. Choose a registered user or group to share the item with.

Choose from the list of users and groups in the pop-up menu, or type the name of a registered user or group in the box.

4. To set access privileges, click the appropriate checkbox.

- To set the same privileges for the folders within this folder or disk, place an X in the box labeled "Make all currently enclosed folders like this one." If you're working with an item that contains a large number of folders, such as a CD-ROM disc, this action may take a few minutes to complete.
- To prevent the folder from being changed, place an X in the box labeled "Can't be moved, renamed, or deleted." If you check this box, no one—not even you—can change the folder. (The folder can still be viewed and copied.)
- If you want the folder to have the same privileges that the folder or disk enclosing it has, place an X in the checkbox labeled "Same as enclosing folder." This box only appears for folders inside shared folders. When you move such a folder to another folder, its access privileges change automatically to reflect those of the enclosing folder.

5. When you're finished setting access privileges, close the Sharing dialog box and then click Save in the dialog box.

Access privilege strategies

Access privileges can be combined in several ways. A few common and useful strategies are summarized here.

- **Allow everyone on the network all access privileges.**
As long as you've turned on guest access, everyone on the network can open, read, and change the files and folders.

	See Files	See Folders	Make Changes
Owner	<input checked="" type="checkbox"/>	<input checked="" type="checkbox"/>	<input checked="" type="checkbox"/>
User /Group	<input checked="" type="checkbox"/>	<input checked="" type="checkbox"/>	<input checked="" type="checkbox"/>
Everyone	<input checked="" type="checkbox"/>	<input checked="" type="checkbox"/>	<input checked="" type="checkbox"/>

continues ►

- **Keep a folder or disk private.** To keep a folder or disk on your own computer private, do not share it. To keep your folder on another computer private, use these settings.

	See Folders	See Files	Make Changes
Owner	<input checked="" type="checkbox"/>	<input checked="" type="checkbox"/>	<input checked="" type="checkbox"/>
User/Group	<input type="checkbox"/>	<input type="checkbox"/>	<input type="checkbox"/>
Everyone	<input type="checkbox"/>	<input type="checkbox"/>	<input type="checkbox"/>

- **Allow access to one other person or group.** This set of privileges allows the owner of the item and one registered user or group to use the item.

	See Folders	See Files	Make Changes
Owner	<input checked="" type="checkbox"/>	<input checked="" type="checkbox"/>	<input checked="" type="checkbox"/>
User/Group	<input checked="" type="checkbox"/>	<input checked="" type="checkbox"/>	<input checked="" type="checkbox"/>
Everyone	<input type="checkbox"/>	<input type="checkbox"/>	<input type="checkbox"/>

- **Keep a folder private but allow others to place files or folders into it.** People on the network can deposit files or folders into this folder but only the owner can see, remove, or change its contents. (This configuration is sometimes called a *drop box*.)

	See Folders	See Files	Make Changes
Owner	<input checked="" type="checkbox"/>	<input checked="" type="checkbox"/>	<input checked="" type="checkbox"/>
User/Group	<input type="checkbox"/>	<input type="checkbox"/>	<input checked="" type="checkbox"/>
Everyone	<input type="checkbox"/>	<input type="checkbox"/>	<input checked="" type="checkbox"/>

- **Set up a folder as a bulletin board.** People can open and read the files in this folder but cannot change them. Only the owner can add files.

	See Folders	See Files	Make Changes
Owner	<input checked="" type="checkbox"/>	<input checked="" type="checkbox"/>	<input checked="" type="checkbox"/>
User/Group	<input checked="" type="checkbox"/>	<input checked="" type="checkbox"/>	<input type="checkbox"/>
Everyone	<input checked="" type="checkbox"/>	<input checked="" type="checkbox"/>	<input type="checkbox"/>

Working with privileges that others have set

When you are using the By Icon or By Small Icon view, the appearance of shared folders indicates the access you have.

Icon	Meaning
	A darkened tab indicates that you own the folder and can set its access privileges.
	A plain tab indicates that you can open and use the folder.
	A strap indicates that you cannot open and use the folder.
	A strap with an arrow indicates that you can put files or folders into the folder, but you cannot open it or use any files or folders within it.

Checking your access privileges

When you open a folder on another computer, icons under the title bar indicate the privileges that you do not have.

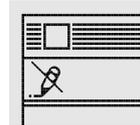

You can't make changes to files in this folder.

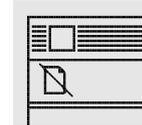

You can't see files in this folder.

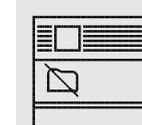

You can't see folders in this folder.

Linking programs

Some programs can exchange information directly with other programs. For example, one program might be able to instruct another program to add a row to a spreadsheet or change the font size of a paragraph.

Programs implement linking in various ways and not all programs have this capability. See the documentation that came with your programs for more information.

Linking to a program on another computer

You can only link to programs that are shared.

- 1. Within your program, choose the menu command that allows you to link programs.**

The menu location and command name depend on the program you're using. You use a dialog box to find the program that you want to link to.

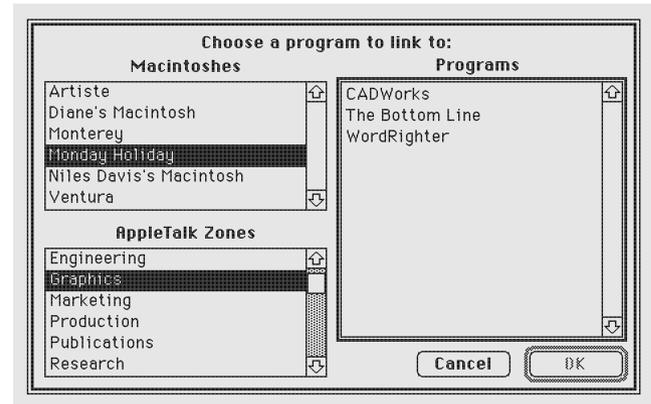

- 2. If your network has zones, select a zone in the lower-left section of the dialog box.**
- 3. Select the Macintosh you want to connect to in the upper-left section of the dialog box.**
- 4. Select the program you want to link to.**

5. Click OK.

In most cases, you need to identify yourself as a guest or a registered user.

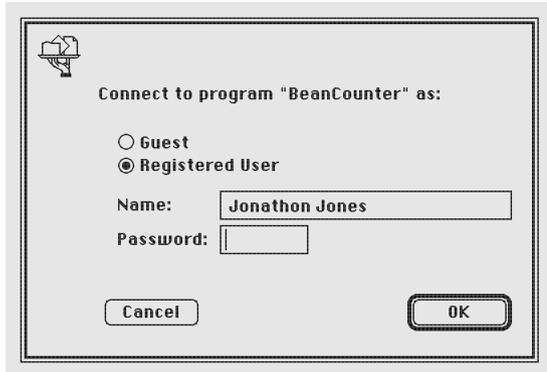

6. Click Guest or Registered User.

If you are a guest, click Guest and go to step 9. If the Guest option is dimmed, guests do not have access to this computer.

7. If you are a registered user, make sure that the name is correct.

8. Type your password.

9. Click OK.

The two programs are now linked.

Disconnecting a program link

To disconnect a link to a program on another computer, quit the program you used to create the link.

Allowing other people to link to your programs

You can allow people on the network to link to programs on your computer.

- First you turn on program linking.
- Then you make a program available for linking by sharing it.
- Then you either allow guest access or allow specific people to link.
- Finally, you open the program.

These steps are outlined in the following sections.

Turning program linking on

When you turn program linking on, your computer is visible to others on the network whenever they attempt to link a program. Before you turn program linking on, make sure that AppleTalk is active and that you have named your Macintosh in the Sharing Setup control panel.

1. **Choose Control Panels from the Apple (🍏) menu and open the Sharing Setup icon.**
2. **In the section labeled Program Linking, click the Start button.**

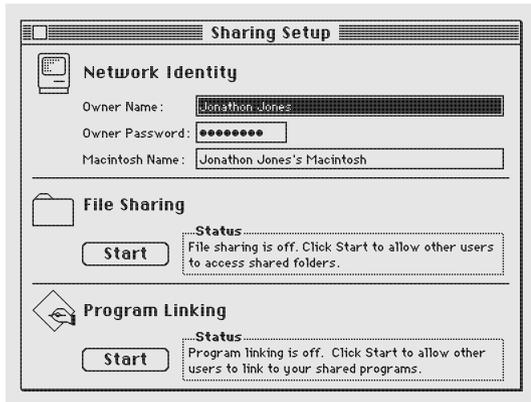

3. **Close the Sharing Setup control panel.**

Once program linking is turned on, you must select programs to share before network users can link to them, as described in the next section.

Selecting a program for linking

Before a network user can link to your program, you need to share it.

1. **Quit the program if it's open, then click its icon to select it.**
2. **Choose Sharing from the File menu.**
3. **Click the box labeled "Allow remote program linking" to place an X in it.**



Click here to share this program.

If the box is dimmed, the program does not support linking.

4. **Close the window.**

At this point, no one but you can link to the program until you turn on guest access or name registered users, as described in the following sections.

5. **Open the program.**

Allowing guests to link to your programs

You can let everyone on the network link to your shared programs.

1. **Choose Control Panels from the Apple (🍏) menu and open the Users & Groups icon.**
2. **Double-click the <Guest> icon.**
3. **Click the box labeled “Allow guests to link to programs on this Macintosh” to place an X in it.**

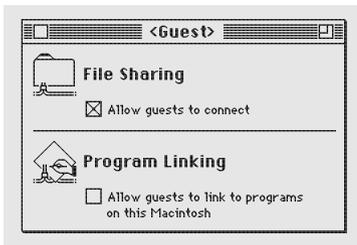

4. **Close the window.**

Guest users can now link to any of the programs you're sharing, as long as the programs are open.

Naming specific users to link to your programs

You can identify the registered users and groups you want to link to your programs.

1. **Choose Control Panels from the Apple (🍏) menu and open the Users & Groups icon.**
2. **Open the icon of a user.**
3. **Click the box labeled “Allow user to link to programs on this Macintosh” to place an X in it.**

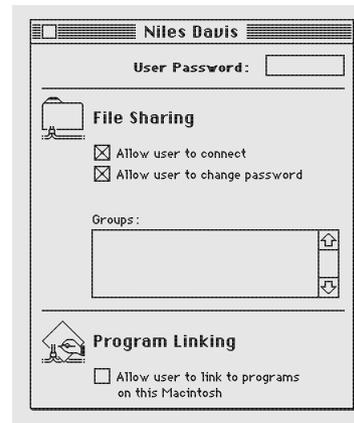

4. **Close the window and click Save in the dialog box.**
5. **To give more registered users access to your programs, repeat steps 2 through 4.**

Expanding Your Computer System

In this chapter

- Using SCSI devices
- Connecting a modem
- Connecting a printer
- Connecting a mouse or other ADB device
- Using sound input and output devices
- Adding memory to your computer

Using SCSI devices

A SCSI device is any product—including hard disk drives, CD-ROM drives, scanners, and printers—that communicates with Macintosh computers by means of a standard electronic interface. (SCSI stands for Small Computer System Interface.) You can attach up to six SCSI devices to your computer by linking them together in a chain that starts at your computer's SCSI port.

The SCSI port on Macintosh PowerBook computers looks like this:

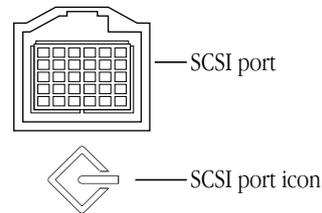

To connect a SCSI device to the SCSI port on your PowerBook, you need an Apple HDI-30 SCSI System Cable.

Setting up one or more SCSI devices for use with your PowerBook involves the steps listed here.

- installing software
- setting SCSI ID numbers
- checking that the SCSI chain is properly terminated
- connecting cables

These steps are described in the following sections.

Installing software

Most SCSI devices come with software that allows your computer to communicate with them. These programs are called drivers. (If no drivers come with a device, then it doesn't need any.) To install a driver, follow the instructions that came with the device.

Setting SCSI ID numbers

Each device in a SCSI chain must have a unique ID number between 1 and 6 so the computer can identify it properly. The information in this section can help you assign SCSI ID numbers to the devices you want to use with your computer.

▲ **Warning:** Using two or more devices with the same SCSI ID number can cause your equipment to malfunction. You could lose information as a result. ▲

Your computer has the SCSI ID number 7, and its internal hard disk has the number 0.

See the documentation that came with your SCSI devices for information about ID numbers and how to change them.

The ID numbers of Apple SCSI devices can be set as follows.

1. Make sure the SCSI device is turned off.

If the device is already part of a SCSI chain, make sure that all devices in the chain are turned off, including the computer.

2. Locate the ID number indicator and switch (usually on the back panel of the SCSI device).

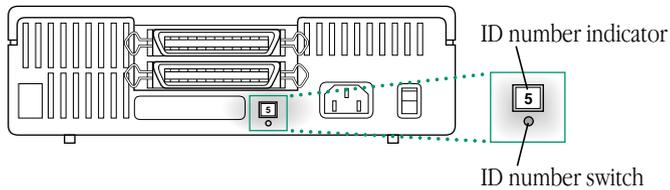

3. Check the ID numbers of all the devices you want to connect.

If all the devices have unique ID numbers, you've finished this part of the procedure. Continue with the next section, "Checking That the SCSI Chain Is Properly Terminated."

4. If you need to change a device's ID number, choose an available number between 1 and 6.

5. Insert the end of a straightened paper clip into the small hole below the ID number indicator.

The small hole gives you access to the ID number switch.

6. Push the ID number switch repeatedly until the number you want appears in the ID number indicator.

Checking that the SCSI chain is properly terminated

To ensure accurate transmission of information, a chain of SCSI devices must have a terminator at each end. Terminators are built into some SCSI devices and can also be added externally.

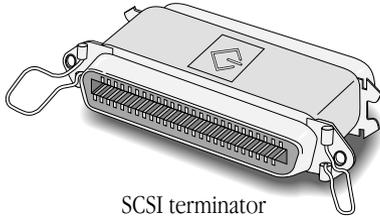

SCSI terminator

- Your PowerBook's internal hard disk, which is always the first device in the chain, has a small built-in terminator. However, for reliable information transfer in a chain of SCSI devices, it should be supplemented with an external terminator as described in these instructions.
- External SCSI devices from Apple do not have built-in terminators.
- External SCSI devices from other vendors may have built-in terminators; see the documentation that came with the device.

If you are attaching one SCSI device

Make sure that there is

- an external terminator between the HDI-30 system cable and the SCSI device *and*
- an internal terminator in the SCSI device, *or* an external terminator attached to the device.

If you are attaching more than one SCSI device

Make sure that there is

- an internal terminator in the first external device, *or* an external terminator between the HDI-30 system cable and the first device;
- an internal terminator in *or* an external terminator attached to the last device; *and*
- no other terminator (internal or external) in the chain.

If you have too many devices with internal terminators, your authorized Apple service provider can remove extra terminators.

Correct chain configurations are shown in the illustration on the following page.

Connecting cables

▲ **Warning:** When making SCSI connections, *always* turn off power to all devices in the chain. Failure to do so can cause the loss of information and damage to your equipment. ▲

1. **Shut down your PowerBook and all SCSI devices in the chain.**
2. **To connect the first device, use an Apple HDI-30 SCSI System Cable.**

Attach the smaller end of the cable to your computer's SCSI port (marked with the icon ) and the larger end of the cable to either SCSI port on the device.

3. **To connect the next device, use a SCSI peripheral interface cable.**

Both cable connectors are the same. Attach one connector to the available SCSI port on the first device, and the other connector to either SCSI port on the next device.

4. **Repeat step 3 for each additional device you want to connect.**

The illustration shows where to add cable terminators.

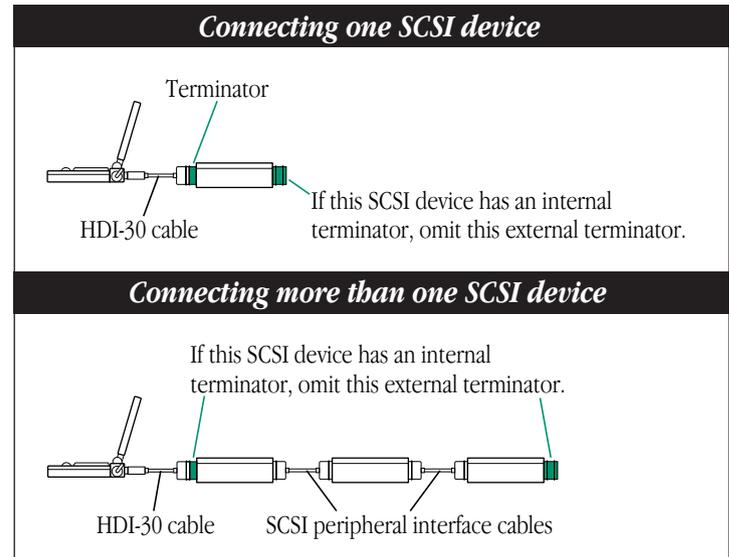

△ **Important:** The total length of a SCSI chain should not exceed 20 feet (6 meters). Apple SCSI cables are designed to meet this restriction. If you are using SCSI cables from another vendor, check the length of the chain. △

Once your SCSI devices are connected, always turn them on before turning on your PowerBook. If you turn the computer on first, it may not be able to start up, or it may not recognize the SCSI devices.

Connecting a modem

Apple offers an optional, low-power, internal fax/data modem for your computer. See the modem manual for information about this modem and how to use it.

You can also connect an external modem to the modem port on the back panel of the computer.

To connect an external modem, follow these steps.

- 1. Make sure the computer is in sleep or shut down.**
- 2. Connect the modem to a power source and to the phone line.**

See the documentation that came with the modem.
- 3. Make sure the modem is turned off.**
- 4. Connect the modem cable to the modem port (marked with the icon ☎).**
- 5. Turn on the modem.**
- 6. Wake or restart the computer.**

If your computer does not have an internal modem, the external modem is ready to use.

If your computer does have an internal modem, continue with step 7.

7. Choose Control Panels from the Apple () menu.

8. Open the PowerBook control panel.

9. Click the External Modem button.

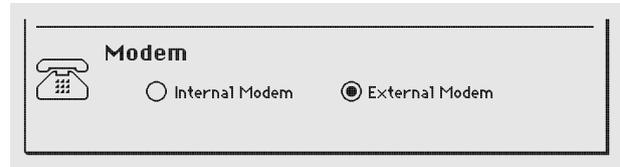

10. Close the control panel.

The external modem is ready to use.

If you have both an internal and an external modem, remember to select the modem you want to use in the PowerBook control panel before opening your telecommunications program.

Connecting a printer

The printer port on your computer can accept either a direct cable connection (to a printer such as the StyleWriter) or a network cable connection (to a printer such as the LaserWriter II_{NTX}). The printer port is marked with this icon: .

Some printers, including the Personal LaserWriter SC, are connected through the SCSI port (marked with the icon .

Follow the instructions that came with your printer to connect it to your computer.

▲ **Warning:** The StyleWriter printer comes with its own power adapter. This power adapter is not interchangeable with your computer's power adapter. Connecting the computer's power adapter to the printer will not damage your equipment, but the printer will not work properly. *Connecting the printer's power adapter to your computer will damage the adapter.* Use each power adapter only with the equipment for which it was intended. (You may want to label the adapters.) ▲

Connecting a mouse or other ADB device

Your computer has one Apple Desktop Bus (ADB) port, to which you can connect optional low-power input devices (such as a mouse) provided by Apple and other vendors. The ADB port has this icon: .

Make sure that any such devices you connect are designed for portable computers. Standard ADB devices designed for desktop Macintosh computers may drain your battery very quickly, in some cases even if the power adapter is plugged in. Low-power devices are marked with this icon: .

By connecting devices in a chain, you can attach up to three devices to the ADB port. See the instructions that came with your ADB device(s) for information about their power consumption, and make sure that the total power drawn by all devices you're connecting does not exceed 200 mA.

Using sound input and output devices

Connecting a microphone

Your PowerBook has a sound input port to which you can connect an external microphone. (Sound recording is described in the chapter *Adapting Your Computer to Your Own Use*.)

1. **Open the door covering the back panel of your computer.**
2. **Plug the microphone into the sound input port on the back panel. The sound input port has the icon .**

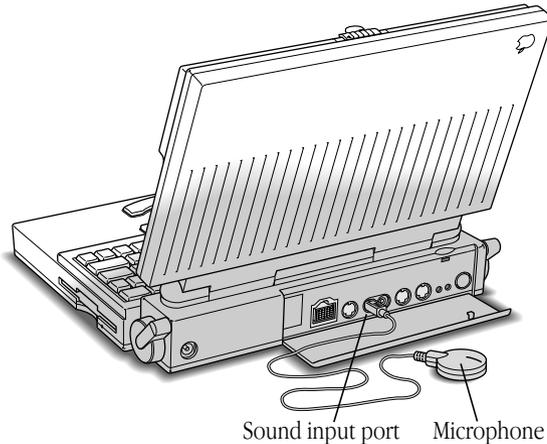

3. **Decide where you want to place the microphone.**

▲ **Warning:** Do not plug a sound output device (such as a pair of headphones) into the sound input port. Doing so may damage your audio equipment. ▲

Sound output devices

The PowerBook also has a sound output port (marked with the icon ) to which you can connect speakers, an amplifier, headphones, or other audio output devices. The sound output port accepts a standard stereo miniplug, like that used to attach headphones to a portable tape player.

Adding memory to your computer

Your PowerBook computer comes with at least 4 MB of RAM. By adding memory upgrade cards you can increase your computer's memory. You can find out how much memory your computer has by choosing About This Macintosh from the Finder's Apple menu.

Apple provides memory upgrades through its authorized dealers. Memory upgrades are also available from other vendors; ask your dealer for more information.

Apple recommends that memory upgrades be installed by an authorized Apple dealer.

Your PowerBook computer also supports virtual memory, a feature that makes use of hard disk space to provide additional RAM.

Travel, Storage, and Service

In this chapter

- Traveling with the computer
- Storing the computer
- Getting service and support
- Getting more information about Macintosh computers

Traveling with the PowerBook

The safety instructions in the first part of this book also apply when you are traveling. In addition, note these precautions:

- Do not transport your PowerBook while it is turned on. Choose Sleep or Shut Down from the Special menu, and wait until the hard disk stops spinning, before you move the computer.
- Transport batteries either inside the computer or in the protective case provided with each battery. Do not transport unprotected batteries.
- Bring backup copies of your system software and other important files on floppy disks, in case you need to reinstall them.
- Do not check your computer as baggage. Carry it with you.
- Do not allow your computer or any hard disks or floppy disks to pass through X-ray machines. Have security officials manually inspect your computer and disks.
- Be prepared to show security officials that your computer is working. Have a charged battery or a power adapter ready to use.

- Some airlines may restrict or prohibit the use of computers in flight. Check ahead to find out what restrictions, if any, apply.
- Take the necessary plug adapters if you're traveling overseas. (You may need to use them with the power adapter.) You do not need a voltage transformer. The power adapter can handle 90 volts to 260 volts AC (48 to 62 Hz).

Check the diagrams below to determine which plug adapters you'll need, or ask your travel agent.

Outlet Type	Locations
	United States, Canada, parts of Latin America, Japan, Korea, the Philippines, Taiwan
	Former Soviet Union, most of Europe, parts of Latin America, the Middle East, parts of Africa, Hong Kong, India, most of South Asia
	Mexico, United Kingdom, Ireland, Malaysia, Singapore, parts of Africa
	China, Australia, New Zealand

Storing the PowerBook

Short-term storage (up to 2 weeks)

1. **Save your work on a hard disk or floppy disks.**
2. **Choose Battery from the Apple (🍏) menu and note the charge level of the battery.**
3. **Choose Shut Down from the Special menu.**
4. **Close the display.**
5. **If the battery is not fully charged, or if you plan to leave the computer in storage for more than a week, plug in the power adapter.**

If the battery is fully charged, you can store the computer *without* its power adapter plugged in for up to a week.

6. **Store the computer in a cool, dry place.**

Storage temperatures should remain between 50°F/10°C and 104°F/40°C. Avoid leaving the computer where temperatures may be extreme or unpredictable—in the trunk of a car, for example.

Long-term storage (more than 2 weeks)

1. **Save your work on a hard disk or floppy disks.**
2. **Choose Shut Down from the Special menu.**
3. **Close the display.**
4. **Recharge the battery.**

Plug in the power adapter or use the recharger.

5. **If you recharged the battery in a recharger, put the battery back into the computer.**
6. **Store the computer in a cool, dry place.**

Storage temperatures should remain between 50°F/10°C and 104°F/40°C. Avoid leaving the computer where temperatures may be extreme or unpredictable—in the trunk of a car, for example.

If you leave the battery in storage for more than 6 months, you may not be able to recharge it.

Service and support

If the PowerBook malfunctions or is damaged

If your computer is malfunctioning but does not appear to be physically damaged, shut it down (and leave the power adapter plugged in, if possible) until you can get help.

If you know or suspect that your computer is physically damaged, disconnect the power adapter, remove the battery, and do not use the computer until it can be repaired.

How to get help

To obtain service in the United States, you can contact either your nearest authorized Apple dealer or Apple Computer directly. If you are in North America, call 800-538-9696 to request the name of an authorized dealer near you. If you are anywhere else, check the local telephone directory.

To contact Apple directly, call 800-SOS-APPL (800-767-2775), Monday through Friday, 8 A.M. to 5 P.M. (Pacific time) to speak to a Technical Support Engineer. If your PowerBook requires service, the Technical Support Engineer will arrange for your computer to be picked up at your location, sent to Apple's centralized repair facility for repair, and returned to you at any location you specify in the United States. Apple has established a centralized repair facility to help you get the best performance from your system.

If you need answers to product questions or information about product updates, your authorized Apple dealer can help you. Apple's technical support organization backs each dealer and international technical support group with an AppleLink network, a state-of-the-art on-line information service, to ensure prompt and reliable assistance. Apple guarantees parts and warranty labor. (Regulations in each country determine the length of warranty. Some restrictions may apply, depending on the country of original purchase.)

If you cannot return to the authorized Apple dealer from whom you purchased your system, go to the nearest service location. For the location nearest you, write or call one of the following:

Apple Computer, Inc.
Customer Relations
20525 Mariani Avenue
Cupertino, CA 95014-6299
USA
(800) 538-9696

Apple Canada, Inc.
7495 Birchmount Road
Markham, Ontario, L3R 5G2
Canada
(800) 268-7796/7637

For locations in other countries, either call the Apple headquarters in your country or write to the United States address on this page.

Apple also offers service plans. One is the AppleCare Service Agreement (available in the United States, Canada, and Australia only), which extends full warranty coverage up to three years. Your AppleCare contract will be honored at any participating authorized Apple dealer within the country of purchase—an added benefit if you relocate.

You can purchase AppleCare at any time, but you may want to purchase it with your system, or at least before your warranty expires, to avoid an inspection at your own expense.

For more information about Macintosh computers

Macintosh user groups

Whatever your level of computer experience, you may be interested in joining a Macintosh user group. Group activities may include new product demonstrations, question-and-answer sessions, and classes on using programs or writing your own programs.

Ask your authorized Apple dealer for the name of the Macintosh user group nearest you, or call 800-538-9696. For names of user groups outside the United States, or if you're interested in starting your own group, contact:

Berkeley Macintosh User's Group
1442-A Walnut Street, #62
Berkeley, CA 94709
USA
510-549-BMUG (510-549-2684)

or

Boston Computer Society
One Center Plaza
Boston, MA 02108
USA
617-367-8080

Technical information

Apple makes technical information for Macintosh computers available through the Apple Technical Library and the Apple Communications Library, both published by Addison-Wesley Publishing Company and available at bookstores.

Apple Technical Library

The Apple Technical Library includes comprehensive technical documentation for all Macintosh computer models as well as the multivolume guide to the Macintosh operating system, *Inside Macintosh*.

Apple Communications Library

The Apple Communications Library offers complete technical information about Macintosh communications products and the Macintosh in a network environment.

APDA

APDA® is Apple's worldwide source for over 300 development tools, technical resources, training products, and information for anyone interested in developing applications on Apple platforms. Customers receive the quarterly APDA Tools Catalog featuring all current versions of Apple and the most popular third-party development tools. Ordering is easy; there are no membership fees, and application forms are not required for most of our products. APDA offers convenient payment and shipping options including site licensing.

To order product or to request a complimentary copy of the APDA Tools Catalog:

APDA

Apple Computer, Inc.

P.O. Box 319

Buffalo, NY 14207-0319

1-800-282-2732 (U.S.)

1-800-637-0029 (Canada)

(716) 871-6555 (International)

(716) 871-6555 (Fax)

AppleLink: APDA

America Online: APDA

CompuServe: 76666,2405

Internet: APDA@applelink.apple.com

Assistance for hardware and software developers

If you plan to develop hardware or software products for sale through retail channels, you can get valuable support from Apple Developer Programs. Write to:

Apple Developer Programs

Apple Computer, Inc.

20525 Mariani Avenue, M/S 51-W

Cupertino, CA 95014-6299

Summary and Shortcuts

Double-click

- **Double-click an object on screen by pointing to the object and clicking twice in rapid succession, without moving the trackball or mouse.**

Double-clicking is a common shortcut for opening an icon or the selected item in a directory dialog box.

Shift-click

- **Hold down the Shift key while clicking.**

Shift-clicking is a way to select more than one icon or item in a list.

Working with icons

Selecting icons

To do this	Take these steps
Select an icon	Click the icon.
Deselect an icon	Click anywhere except the selected icon.
Select multiple icons	While holding down the Shift key, click each icon.
Deselect an icon in a group of selected icons	While holding down the Shift key, click the icon.
Select multiple icons that are near each other	<ol style="list-style-type: none">1. Place the pointer at one corner of the group of icons.2. Drag diagonally to select the icons, then release the trackball or mouse button.
Select contiguous icons in a list	<ol style="list-style-type: none">1. Place the pointer to the left of the top icon or the bottom icon.2. Drag up or down the list, releasing the trackball or mouse button when the pointer is left of the last icon.
Select text in an icon's name	Click the icon's name (not the icon itself).

Opening an icon

You open an icon by selecting it and choosing Open from the File menu or using the keyboard shortcut **⌘-O** or **⌘-Down Arrow**. Or you can double-click the icon.

Moving, copying, and renaming an icon

To do this	Take these steps
Move an icon	Drag the icon to where you want it.
Copy an icon onto another disk	Drag the icon to the icon of the other disk (or to an icon or window that belongs to that disk).
Copy an icon on the same disk	<ol style="list-style-type: none">1. Click the icon to select it.2. Choose Duplicate from the File menu, or press ⌘-D.3. If you wish, rename the icon and drag it to a new location. You can also make a copy by holding down the Option key while you drag the icon to another folder or window.
Rename an icon	<ol style="list-style-type: none">1. Select the icon's name by clicking the name (not the icon).2. Type a new name and press the Return key.

Working with windows

Making a window the active window

You make a window active by clicking inside it. You can also make a window active by clicking its icon (even though it's dimmed) and choosing Open from the File menu, or by double-clicking the dimmed icon.

Moving a window and changing its size

To do this	Take these steps
Move a window	 Drag the window's title bar (at the top of the window) to the new location.
Resize a window	 Drag the size box (in the lower-right corner).  Or click the zoom box (in the upper-right corner).
Close a window	 Click the close box (in the upper-left corner). Or choose Close from the File menu. Or press ⌘-W .

Scrolling through the contents of a window

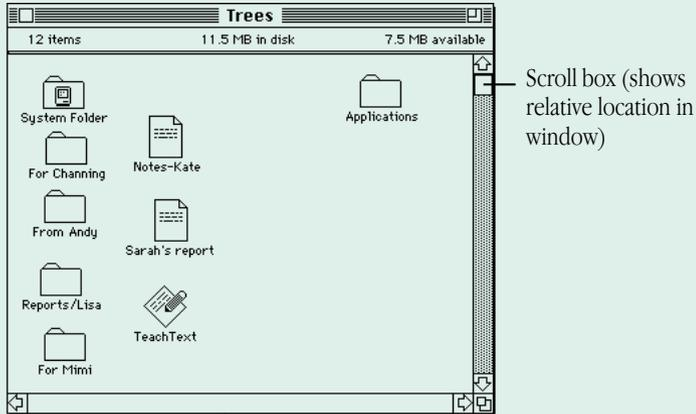

Scroll arrow (used to view the content beyond the window's borders)

Every window has two scroll bars, one for vertical scrolling and one for horizontal scrolling. (A gray scroll bar indicates more content beyond window's borders; a clear bar indicates all content is visible.)

- **Click the up, down, left, or right scroll arrow.**
- **Click the vertical or horizontal scroll bar (when it's gray).**
- **Drag the vertical or horizontal scroll box along its scroll bar.**

Opening higher-level folder windows

You can open a higher-level folder window (whose contents include the active window) from a pop-up menu in the active window's title.

- 1. Hold down the ⌘ key as you press the active window's title.**

A pop-up menu of the higher-level folders (and the disk) appears.

- 2. Drag to choose a higher-level folder (or the disk), and then release the trackball or mouse button.**

The folder (or disk) window you chose appears as the active window.

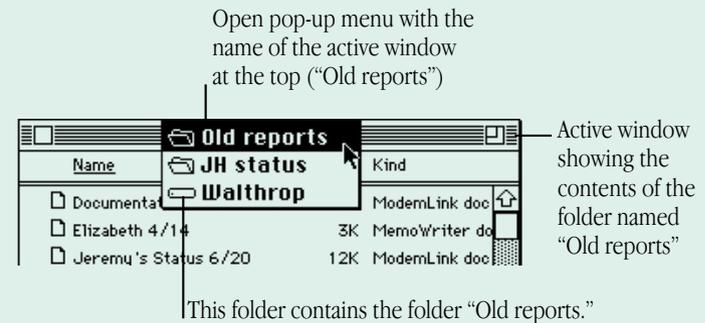

If you hold down the Option key as well as the ⌘ key, the old window closes when the new window appears.

Using the outline form in list views

Any list view you choose from the View menu (that is, any view except the icon and small icon views) shows the contents of the active window in outline form. You can see the contents of a folder without opening the folder in its own window.

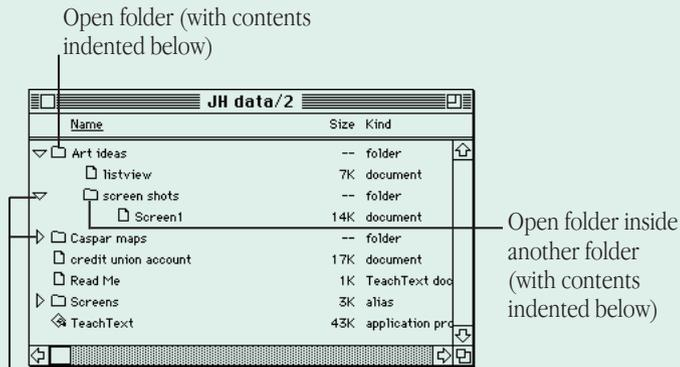

A downward-pointing triangle indicates that the folder's contents are displayed; a right-pointing triangle indicates that the folder's contents are hidden.

Click the triangle next to a folder name to display or hide the folder's contents in the active window. If you double-click a folder, it opens in its own window, and its outline view closes.

- ❖ *Shortcuts:* When a folder is selected in an outline view, pressing \mathbb{A} -Right Arrow displays its contents and \mathbb{A} -Left Arrow hides its contents. ❖

Working with menus

Macintosh menus come in two types: pull-down menus and pop-up menus. The menus in the menu bar are pull-down menus.

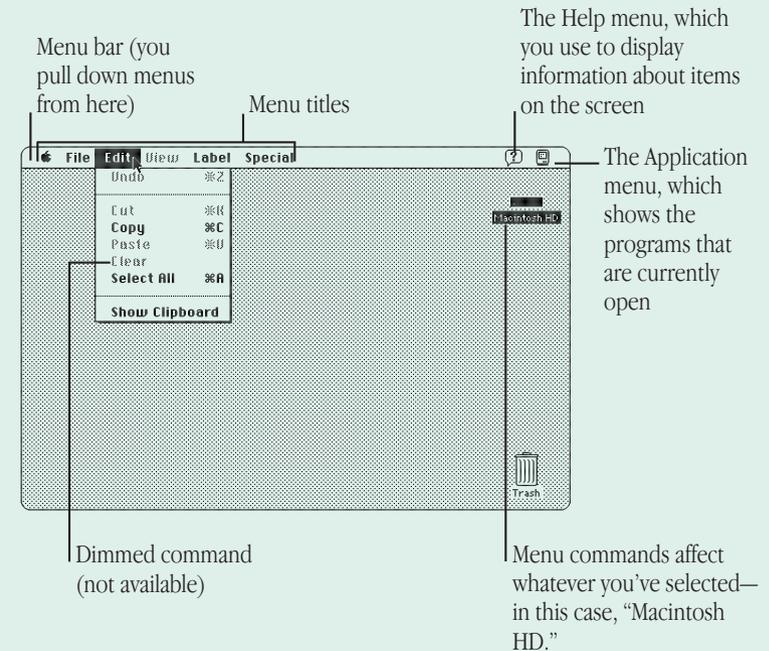

Pop-up menus often appear in dialog boxes that you use to set options or preferences. You can recognize a pop-up menu by a small solid triangle, pointing down, next to its name. The name shows the current option or preference.

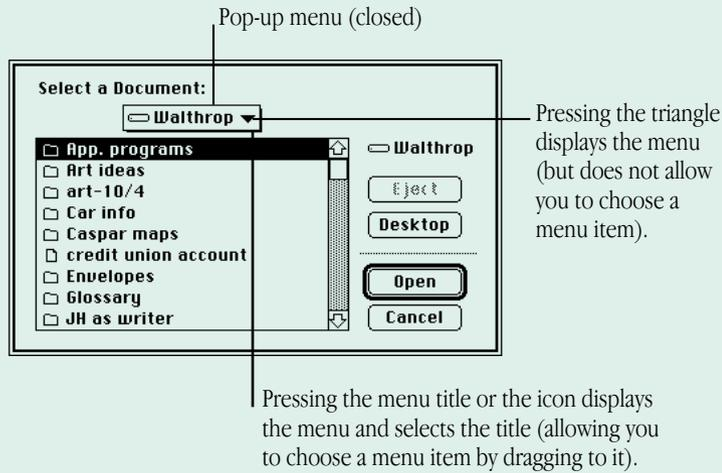

Choosing an item from a menu

To choose a command from a menu, point to the menu name, press to “pull down” or “pop up” the menu, drag to the item you want to choose so that it’s highlighted, and then release the mouse or trackball button.

Choosing an item from a submenu

Some menu items are submenus. A submenu name has a small solid triangle next to it, pointing to the right. The submenu opens when the submenu name is highlighted.

To choose an item in a submenu:

1. **Point to the menu name and press to open the menu.**

continues ►

2. Drag to the menu item so that the submenu appears.



3. Drag sideways to the submenu, drag to the submenu item you want to choose so that it's highlighted, and then release the trackball or mouse button.

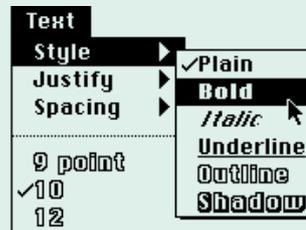

Keyboard shortcuts in the Finder and in directory dialog boxes

Key	Action
Up, Down, Left, or Right Arrow key	Selects the next item in the direction of the arrow
Tab key	Selects the next item alphabetically (except in a directory dialog box and the Chooser)
Character key (a, b, c . . .)	Selects the first item whose name begins with that character (or the character following closest to it in the alphabet)
⌘–Down Arrow	Opens the selected icon
⌘–Option–Down Arrow	Opens the selected icon and closes the current folder
⌘–Up Arrow	Opens the folder that contains the current folder
⌘–Option–Up Arrow	Opens the folder that contains the current folder and closes the current folder
Return or Enter	In the Finder: Selects the selected icon's name for editing or saves the edited name In a dialog box: the same as clicking the button with the bold outline around it

Troubleshooting

This section describes possible causes and solutions for some common problems you may have with your Macintosh PowerBook or associated equipment provided by Apple.

This section is not comprehensive. Check the appropriate reference section for additional help on specific topics.

Also check the documentation that came with your other equipment and with your programs for more information.

▲ **Warning:** If you have a problem with your Apple computer equipment and nothing presented in the manuals that came with the equipment solves the problem, call Apple Computer directly at 800-SOS-APPL (800-767-2775), or take the computer or accessory to your authorized Apple dealer or service provider. Attempting to repair the equipment yourself may void the Limited Warranty. Contact your authorized Apple dealer or service provider for additional information about this or any other warranty question. ▲

The PowerBook

The computer won't start.

- The computer may be on, but the screen brightness or contrast may be turned down. Adjust the brightness and contrast controls to see whether an image appears on the screen.
- The battery may be drained. Plug in the power adapter, wait 15 minutes, and then try to turn on the computer.
- There may be a temporary problem with the computer's power system. Use a paper clip or similar object to press the reset button on the computer's back panel, and then try to turn the computer on again.

The computer just stopped.

- The computer may have gone to sleep. Press any key on the keyboard (except Caps Lock) to wake it again.
- The battery may have drained so far that the computer has put itself to sleep to protect the contents of RAM. Plug in the power adapter, wait 15 minutes, and then turn the computer on again.
- The computer may have “crashed” due to temporary software problems. Click the Restart button on the screen (if you see one), or use a paper clip or similar object to press the reset button on the computer’s back panel. If you use these methods, you will lose any work you have not saved.

The computer is very hot.

- It is normal for the computer to be warm to the touch while you are using it, especially on the side beneath the keyboard. If the computer seems unusually hot, try the following:
 - plug in the power adapter
 - turn down the screen brightness
 - use the Maximum Conservation setting in the PowerBook control panel
 - make sure processor cycling is on in the PowerBook control panel
 - put the computer to sleep or shut it down

See Chapter 7 for more information on reducing your computer’s power consumption.

The computer exhibits odd behavior, such as many unexplained system failures.

- A common cause of unexplained problems is multiple System Folders on your computer's startup disk. The System Folder that the PowerBook is using to operate is marked with an icon. Use the Find command in the Finder's File menu to locate any other System Folders, and throw them in the Trash.
- You may have a virus on your hard disk. Obtain a virus-detection program, use it to check all your disks, and eliminate any viruses the program finds.
- You may be using a program that's not compatible with your computer's system software. Check the information that came with the program or contact the manufacturer.
- You may have added a control panel or system extension that is incompatible with other programs you use. Restart the computer with the Shift key held down until you see the message "Extensions off." If the problem does not recur, remove any such items you recently installed.

Power

The battery is draining too fast.

- Turn down the screen brightness, turn off virtual memory, move the Battery Conservation slider in the PowerBook control panel to Maximum Conservation, or work with the power adapter plugged in.
- You may be using an input device (such as the mouse intended for desktop Macintosh systems) not designed for PowerBook computers. Make sure to use only low-power input devices.
- Your computer supplies power to the modem whenever a communications program is open. Quit your communications program if you aren't using it.
- If you aren't using network services, you can also save power by turning off AppleTalk in the Chooser.
- Your battery may need to be discharged and recharged completely. See Chapter 7.
- Older PowerBook batteries do not hold a charge as well as new ones. You may need to replace the battery.

The battery can't be recharged.

- There may be a loose connection. Make sure all plugs are securely attached.
- The battery may be damaged or dead. Obtain a replacement battery from your authorized Apple dealer.
- The outlet may have no power.
- If the adapter or recharger is plugged into a power strip, the strip may not be turned on.
- The recharger may be damaged. Try recharging the battery in the PowerBook.

The computer goes to sleep too often.

- Open the PowerBook control panel and move the Battery Conservation slider toward Maximum Performance.

The computer doesn't go to sleep automatically.

- You may have selected “Don't sleep when plugged in” in the Options section of the PowerBook control panel. Click the box to remove the X.
- You may be connected to a shared disk on the network. If you are not using the information on the shared disk, disconnect from it.
- The printer or modem port may be in use. Quit your telecommunications program or turn off background printing in the Chooser (if the documents you're printing can wait until later).
- One or more applications may be doing work in the background. You can choose Sleep from the Special menu to override them.

See Chapter 7 for more information about batteries and power consumption.

The screen

The screen looks blurred or out of focus.

- The viewing angle may not be optimal. Tilt the display on its hinge until the screen looks better.

The screen is too dark.

- When you first turn on your computer, it may take several minutes for the screen brightness to “warm up,” especially if you’ve chosen a high setting.
- The screen brightness or contrast may not be optimal for the surrounding lighting. Adjust the brightness or contrast setting.
- The screen dims automatically when the battery starts to run low. You may need to recharge or replace the battery before you can turn up the brightness.

There are ghost images or black dots on the screen.

- When the computer is left on for many hours, temporary defects may appear on the screen. Put the computer to sleep. The longer the computer was left on, the longer it will take for the images to fade, but they will eventually disappear.

The pointer moves too fast/too slowly.

- You need to adjust the pointer’s tracking speed. Open the Mouse control panel and choose a more comfortable setting.

The pointer won’t move at all.

- A software problem may have caused the computer to “freeze.” Restart the computer by using a paper clip or similar object to press the reset button on the computer’s back panel. You will lose any work you have not saved.

The pointer has disappeared.

- Processor cycling may cause the pointer (especially the I-beam) to disappear temporarily. Roll the trackball or mouse slowly until you locate the pointer.

A window has disappeared.

- Another open window on the desktop may have covered the window you're looking for. Move, resize, close, or hide windows you aren't using until you see the one you want.
- Windows belonging to open but inactive programs may be hidden. Choose Show All from the Application menu to show hidden windows.

An icon is blinking in the menu bar.

- One of your programs needs your attention. For example, you may have set the Alarm Clock to go off at a particular time, or PrintMonitor may be alerting you to a printing problem. Make the program active and take the necessary action.

Memory

A “not enough memory” message appears when you try to open a program.

- Quit any programs you aren't using, then try again to open the program you want. If that doesn't work, restart the computer. Sometimes restarting makes additional memory available.
- If you are using a RAM disk or a disk cache, reduce its size and then restart the computer.
- Use extra space on your hard disk as virtual memory to increase the amount of memory available for opening programs. (Use virtual memory only when the power adapter is plugged in.)
- If you consistently want to open more programs than memory allows, you can purchase a memory expansion card from your authorized Apple dealer.

SCSI devices

You can't turn on the computer after connecting a SCSI device.

- SCSI devices connected to your computer must be turned on before the computer itself. Turn on the SCSI device(s) first, and then turn on the computer.

The computer doesn't recognize your SCSI devices.

- The devices may be off. Check to make sure that they are plugged in and turned on.
- If the device is a disk drive, it may need to be initialized before you can use it. See the instructions that came with the device.
- The software (driver) needed to communicate with the device may not be installed in your System Folder. See the instructions that came with the device.
- Two or more devices in the SCSI chain may have the same ID number. Check the ID number of each device to make sure each one has its own number between 1 and 6, and change any numbers that are not unique.
- When connecting SCSI equipment, it is important to use the right cables and the correct number and placement of cable terminators. Check the cables and terminators in the SCSI chain and make sure that all cables are firmly attached.

See Chapter 13 for more information about working with SCSI devices.

Disk drives and disks

The computer won't start up from its hard disk, or the hard disk icon doesn't appear on the desktop.

- There may have been a temporary software problem. Shut down the computer, wait at least 10 seconds, and then turn it on again.
- There may be a problem with the system software on the hard disk. Start up the computer with the *Disk Tools* disk. If the hard disk's icon appears, reinstall system software as described in Chapters 6 and 8. Disk repair programs can sometimes fix problems of this kind.
- The information on the disk drive may be damaged. Try using a disk repair program to repair or recover the information. If this doesn't work, you'll need to reinitialize the hard disk. See Chapter 8.
- There may be a mechanical problem with the disk drive. If none of the above suggestions works, take the computer to an authorized Apple service provider.

The hard disk keeps stopping and starting again.

- The hard disk may be going to sleep to conserve power. Open the PowerBook control panel and move the Battery Conservation slider toward Maximum Performance.

The hard disk is full.

- You can reclaim space on your hard disk by removing unneeded files; turning off virtual memory; or purchasing a disk optimization program to reorganize the information on the hard disk.

The icon of a floppy disk doesn't appear on the screen.

- There may be a problem with the disk or disk drive. Try inserting a different disk. If its icon does appear, the original disk is probably damaged. You may be able to repair the disk or recover some of the information on it. See Chapter 8. If the icon of the second disk does not appear either, take the computer or disk drive to an authorized Apple service provider for repair.

A disk you use with your PowerBook computer is not recognized by another Macintosh.

- Some disk drives cannot recognize high-density disks. If the disk is high-density (marked with the icon ) , try inserting an 800K or 400K disk in the disk drive of the other Macintosh. If that works, copy your files to an 800K disk or a 400K disk. If you regularly plan to use floppy disk drives of different types, use the lower-capacity disks in all drives.
- The disk may be damaged. Try using Disk First Aid or another disk repair program to fix it. If this problem occurs frequently, one of the disk drives may need repair.

You can't eject a disk from a floppy disk drive.

- There may be a temporary mechanical problem with the disk drive. Restart the computer and hold down one of the trackball buttons while the computer starts up. If that doesn't work, carefully insert the end of a straightened paper clip into the small hole near the disk drive's opening, and push gently until the disk is ejected.

A message says that a disk is not initialized—but you know that it is.

- The disk may not be seated properly in the disk drive. Eject it and try inserting it again.
- The disk may be damaged. If you insert another disk in the drive and the message does not appear, you can assume that the original disk needs repair. See Chapter 8 for information about recovering information from a damaged disk. If the second disk is also not recognized, take the computer or disk drive to an authorized Apple service provider.

You can't delete a file on a floppy disk.

- The disk may be locked. Unlock it by sliding the tab so that it covers the hole at the corner of the disk.
- The file may be locked. You can unlock it in its Info window (choose Get Info from the File menu). Or you can hold down the Option key while you choose Empty Trash from the Special menu.
- An application program may be using the file. You'll need to quit the program.

You can't save or copy files onto a floppy disk.

- The disk may be locked. Unlock it by sliding the tab so that it covers the hole at the corner of the disk.
- The disk may be full. Delete files you no longer need or use a different disk.

See Chapter 8 for more information about working with disk drives and disks.

Modems

The external modem doesn't work.

- The modem may be turned off or improperly connected. Make sure that it is turned on and that all connections are correct.
- The modem port may not be activated. Open the PowerBook control panel and make sure that External Modem is selected.

The internal modem doesn't work.

- The modem port may not be activated. Open the PowerBook control panel and make sure that Internal Modem is selected.

See the modem manual for more information about using and solving problems with your modem.

Printers

Your computer can't find the printer.

- The printer may be turned off. Turn it on.
- If it's a network printer, there may be a problem with the network. Check with your network administrator.
- The printer may not be selected in the Chooser. Open the Chooser and select the printer you want to use.

Your printer does not appear in the Chooser window.

- The printer may not be connected properly. Check the connections between your computer and the printer, including relevant sections of the network if appropriate.
- The printer software may not be in your System Folder. Close the Chooser and install the software you need.
- AppleTalk must be active before you can use a network printer. Make sure that AppleTalk is active in the Chooser.
- If your network has zones, the printer you want may not be in the currently selected zone. Make sure the correct zone is selected.
- There may be a problem with the network. Check with your network administrator.

The network printer keeps restarting.

- Someone on the network may be using a different version of the printer software. Everyone connected to a network should use the same printer software version. Consult the network administrator for more information.

Nothing happens, or you see an error message, when you try to print.

- The printer may not be turned on. Make sure it is turned on and warmed up.
- The printer may be out of paper or have some other problem. Check the printer status lights and any messages on your screen.
- If an error message states that the printer could not print your document, turn the printer off for at least 10 seconds. Then turn it on again, wait for it to warm up, and try to print again.

Your documents are printed with the wrong fonts.

- The printer may not have your fonts in its memory and is substituting other fonts. You may be able to add the necessary fonts to your printer (see Chapter 11), or print on a different printer that has the fonts you want. If you have a LaserWriter, you can turn off Font Substitution in the Page Setup dialog box.

See Chapter 11 for general information about printing documents. See the printer manual for more information about your printer's features or problems with the printed output.

Networks

You can't find or can't open icons needed to set up file sharing.

- One or more icons may be in the wrong place. Make sure that the Sharing Setup icon is in the Control Panels folder, and that the File Sharing Extension file, the Network Extension file, and the AppleShare file are in the Extensions folder. (Both folders are inside the System Folder.)
- Some network software may not be installed correctly. Reinstall system software from a backup copy or check with your network administrator.

The shared disk you want to connect to does not appear in the Chooser window.

- AppleTalk must be active before you can use a shared disk. Make sure that AppleTalk is active in the Chooser.
- If your network has zones, the shared disk you want may not be in the currently selected zone. Make sure the correct zone is selected.
- The computer that the disk is on must be turned on before the disk can be shared. Make sure that computer is on.
- The shared disk may be temporarily unavailable. Wait a few moments to see if its name appears in the Chooser.
- There may be a problem with the network. Check with your network administrator.

You can't open a shared disk or folder.

- You may not have the access privileges needed to use the disk or folder. Ask the network administrator or the owner of the shared item to grant you access.
- You may have entered your name or password incorrectly when you tried to open the shared disk or folder. Check with the owner of the item to make sure you are entering your name and password correctly, and try again.

You can't connect to your own computer from another Macintosh.

- Make sure that your computer is turned on and connected to the network. Make sure that file sharing is turned on, you have the correct access privileges, and you entered your name and password correctly.

See Chapter 12 for more information about using your computer on a network.

Application programs

A program won't open.

- Some programs can't be opened from a locked floppy disk. Make sure the disk is unlocked.
- The program may be damaged. Recopy it from a known good source (such as the original program disk).
- There may not be enough memory available to open the program. Quit other programs or change the program's memory size in its Info window.

A program runs very slowly.

- Some programs are slowed by processor cycling. You can turn processor cycling off; see Chapter 7. Turning processor cycling off will drain your battery faster and cause the computer to become hotter.

A program doesn't work, or malfunctions consistently.

- You may have more than one copy of the program on your hard disk. Remove extra copies by dragging them to the Trash.
- The program may be damaged. Recopy it from a known good source (such as the original program disk).
- Your version of the program may be incompatible with your system software. Consult the software manufacturer to find out which version of the program you should be using.
- The program may be using less memory than it needs to work with your documents. Choose Get Info from the File menu and increase the memory size.

A message says that a program could not be found.

- You may be trying to open a document created with a program you don't have on your computer, or created with a different version of the program. Obtain the correct program and version. Or open the document with another program that can read its format. (If another program can open a document, the program icon becomes highlighted when you drag the document icon to it.)

You just did something you didn't mean to do.

- If you have not yet taken any other action, you can usually undo your most recent action (even if you aren't sure what it was). Most programs have an Undo command in the Edit menu (⌘-Z). Choose Undo to go back one step in your work. You cannot undo more than one action.

See the documentation that came with your programs for more information about their operation and features.

Appendix A

Keyboard and Character Sets

Tab key: Moves the insertion point to the next stopping place (such as a tab stop or data field).

Delete key: Deletes selected material, or the character to the left of the insertion point.

Return key: Moves the insertion point to the beginning of the next line. In a dialog box, pressing Return is the same as clicking the outlined button.

Caps Lock key: A Shift key for letters only (numbers and symbols aren't affected).

Shift key: Produces capital letters (or the upper character on the key).

Control key: In combination with other keys, provides shortcuts or modifies actions.

Option key: In combination with other keys, produces special characters or modifies actions.

⌘ (Command) key: Works in combination with other keys as an alternative to choosing a menu command.

Arrow keys: Move the insertion point, as an alternative to using the trackball. In some programs, the arrow keys have other functions.

Using Caps Lock

The Caps Lock key on PowerBook computers does not stay depressed even when it's locked. You can tell whether Caps Lock is on or off by looking at the menu bar. An arrow appears to the left of the Help menu icon when Caps Lock is on.



To turn Caps Lock on or off, press the Caps Lock key.

Typing special characters and symbols

You can type a variety of special characters (with diacritical marks) and symbols by pressing modifier keys in combination with certain letter and number keys.

The Key Caps program, which is installed with the system software, shows you the characters produced when you type certain keys and key combinations in the fonts available on your computer. Choose Key Caps from the Apple (🍏) menu, then choose the font from the Key Caps menu.

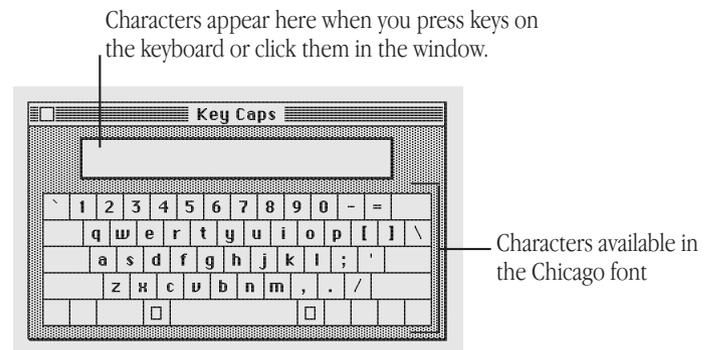

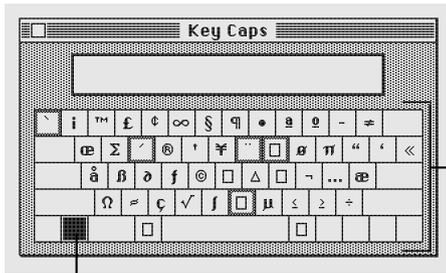

Characters available in the Chicago font when the Option key is pressed

The highlighted key represents the key held down on the keyboard—in this case, the Option key.

To type a character with a diacritical mark (such as an acute accent or an umlaut), you press the Option key along with a specific letter key, and then type the character.

Diacritical mark	Key combination
Grave accent (`)	Option-` , then type the character
Acute accent (´)	Option-e, then type the character
Circumflex (^)	Option-i, then type the character
Tilde (~)	Option-n, then type the character
Umlaut (¨)	Option-u, then type the character
The letter “c” with a cedilla (ç)	Option-c

If the character appears *after* the diacritical mark (rather than with it), then the marked character is not available in the font you’re using.

Appendix B

Exchanging Disks and Files With MS-DOS Computers

Apple File Exchange is a file format conversion program supplied on your hard disk. The program and *translator* files are stored in the Apple File Exchange Folder.

You can use the program to initialize a disk in MS-DOS (or Apple II ProDOS) format and convert files to and from MS-DOS (or ProDOS). Apple File Exchange cannot open converted files; you need to open them with an application program that recognizes the converted files.



Apple File Exchange

Initializing a disk in MS-DOS format

(You can also follow these instructions to initialize a disk in ProDOS format.)

1. Locate the Apple File Exchange icon on your hard disk and open it.

When you open the program, the contents of the active window are listed on the left side and an empty box appears on the right side.

2. Insert a blank disk into your floppy disk drive.

A message reports that the program can't read the disk and asks if you want to initialize it. The message lists the formats available in Apple File Exchange, including Macintosh, MS-DOS, and ProDOS.

(You can initialize a disk that is not blank by inserting it, clicking the Drive button until the disk's name appears, and then choosing Erase Disk from the File menu.)

3. Click MS-DOS.

4. If necessary, click the capacity (in K) of the disk you inserted.

If you want to initialize a high-density (⌘) disk in MS-DOS format, 1440K is the only option and it is already selected. If you inserted a double-sided disk, click 720K.

Apple File Exchange cannot initialize a high-density disk in 720K format, nor can it read a double-sided disk that has been initialized in the high-density (1.4 MB) format.

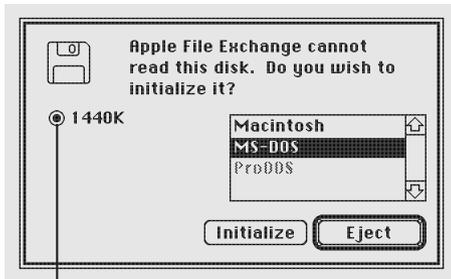

Disk capacity is the same for Macintosh and MS-DOS high-density disks.

5. Click Initialize.

When initialization is finished, a message asks you to name the disk.

6. Type a name for the disk, and then click OK.

MS-DOS filenames can have up to eight characters, followed by an optional period and up to three characters.

The name of the disk you initialized appears above an empty window. The disk's icon doesn't appear on your Macintosh screen because the Macintosh can't recognize a disk in MS-DOS format.

7. Choose Quit from the File menu.

Converting files to and from MS-DOS format

Apple File Exchange provides two methods of file conversion—text and binary. Text translation is for text files, and binary translation is for other file types.

Apple File Exchange can also use translator files designed to convert files into formats that specific programs can use. One such translator file is provided with Apple File Exchange: DCA-RFT/MacWrite, which converts documents between MacWrite format (for the Macintosh) and Document Content Architecture/Revisable Form Text format (used by many MS-DOS word-processing programs).

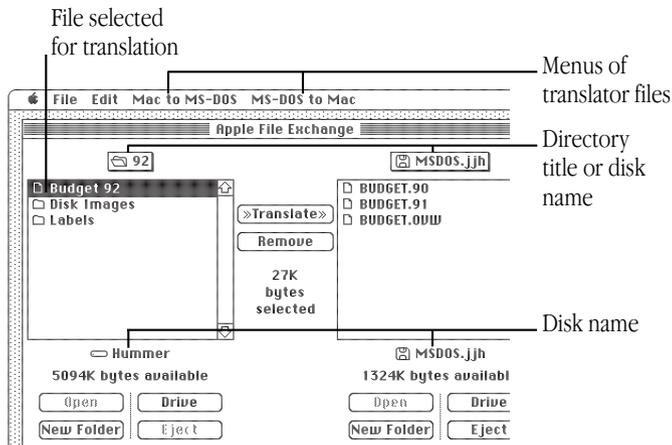

Follow these steps to translate an MS-DOS (or ProDOS) file:

1. Locate the Apple File Exchange program and open it.

Apple File Exchange is supplied on one of your system software disks.

When you open the program, the contents of the active window are listed on the left side and an empty box appears on the right side.

2. Insert the floppy disk containing the files you want to translate.

3. Use the Open, Drive, and Eject buttons to display the files you want to translate and the disk or folder where you want to store the translated files.

4. Click the names of the files or folders you want to translate.

The appropriate translation menus (for translating from or to Macintosh format) appear in the menu bar when you select MS-DOS files.

continues ►

5. Pull down the translation menu you want.

6. Make sure that the translators for the types of files you selected have checkmarks; if not, choose them so checkmarks appear next to them.

An active translator has a checkmark. The default translator has a diamond (indicating that it's always active). Choosing an active translator makes it inactive.

7. Compare the size of the files or folders selected for translation with the space available on the destination disk.

Total space required appears between the lists; the space available on the destination disk appears below its name.

If the size of the selected items is greater than the space available on the destination disk, deselect some of the items, remove some files on the destination disk (click Remove), or use another destination disk (click Eject).

8. Click Translate.

If two or more active translators (other than Text or Default) are capable of translating a selected file, a message asks you to select the translator you want.

If the names of files or folders on the destination disk are the same as those of files or folders being translated, a message asks you to rename the file being translated.

If you need to select options before a file is translated, a dialog box appears in which you can select the options.

9. Respond to any messages by selecting a translator, renaming a file, or selecting options.

When Macintosh files are translated into MS-DOS files, filenames may be shortened to conform to MS-DOS naming conventions.

10. Choose Quit from the File menu.

- ❖ *Converting MS-DOS files on a file server:* Some file servers can store information created by both Macintosh and MS-DOS computers. For example, the AppleShare PC program allows MS-DOS computers to store and translate files on an AppleShare file server. Consult your authorized Apple dealer or representative for more information about using a file server and MS-DOS files. ❖

Other file-conversion options

Apple File Exchange's File menu provides several other options to assist you with file conversions.

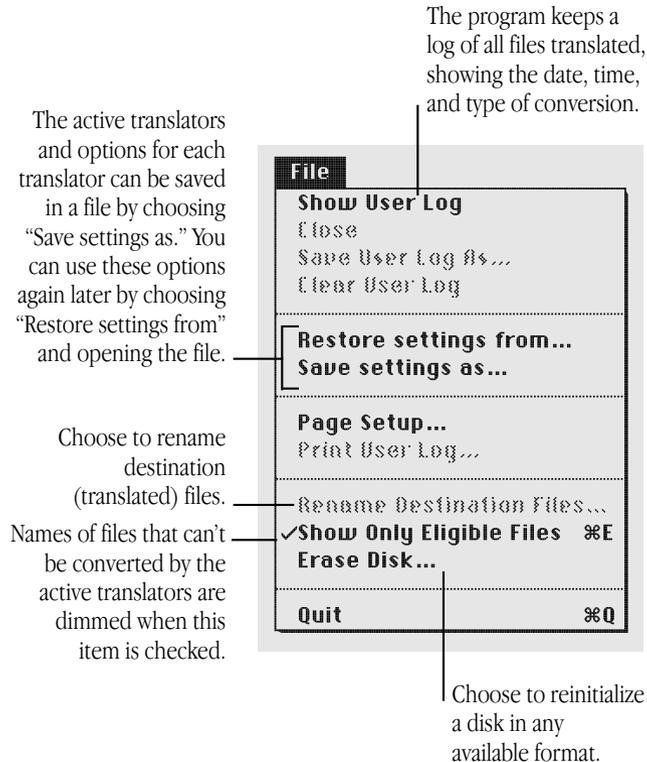

To see explanations of the translators Apple File Exchange uses, choose About Apple File Exchange from the Apple menu. Select a translator from the list, and then click the About button for more information. (Click Done to return to the program's window.)

Appendix C

Map

The Map control panel lets you set your computer's location and find out the distance and the time difference between your location and cities around the world. If you travel with your computer and use Map to reset your location accordingly, the time (in the Date & Time control panel) is automatically reset to the local time.



Certain programs (in networking and telecommunications, for example) can use your computer's location to account for time zones and distances when making calculations.

Setting your location

1. Choose Control Panels from the Apple (🍏) menu and open the Map control panel.

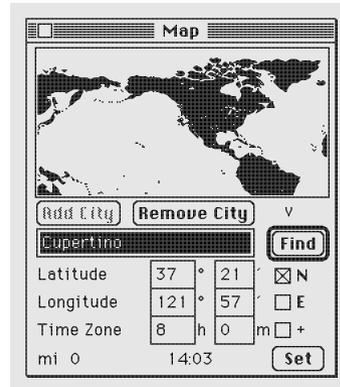

To magnify the map in the control panel (showing less of the world at a larger scale), hold down the Option key while you open Map.

continues ►

2. Type the city nearest your current location and then click the Find button (or press the Return key).

If you aren't sure how the city is spelled, type the first few letters and press the Return key. If the city isn't found, you can add it to the list of cities stored in Map (instructions are given elsewhere in this appendix).

3. Click the Set button.

Your current location is indicated by a blinking cross.

Comparing locations

After you set your computer's location, you can use Map to find out:

- the distance from your location to another location
- the time at another location
- the time difference between your location and another location

Open the Map control panel and find or add the other location (instructions are given elsewhere in this appendix). You can also choose a location by clicking anywhere on the map (the unnamed location's coordinates appear in the boxes for latitude and longitude).

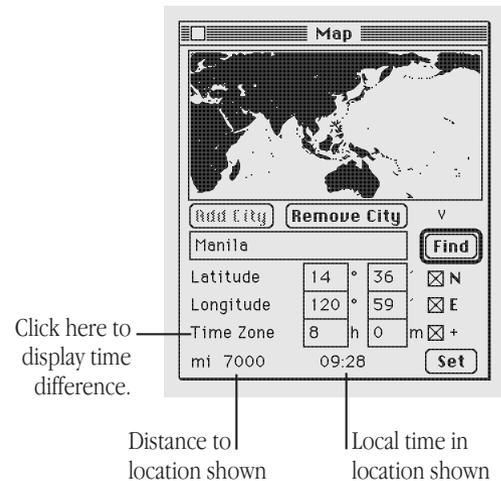

The distance to and the time at the other location are shown at the bottom of the window. The distance is based on the shortest possible route (called the great circle).

To find out the time difference between your location and the other location, click the words “Time Zone.” Click again to see the other location’s time zone.

Finding a location

The Map has a list of locations, with information on the latitude, longitude, and time zone of each location.

- 1. Choose Control Panels from the Apple (🍏) menu.**
- 2. Open the Map control panel.**

To magnify the map in the control panel (showing less of the world at a larger scale), hold down the Option key while you open the Map control panel.

- 3. Type the city you are looking for and then click the Find button (or press the Return key).**

If you aren’t sure how the city is spelled, type the first few letters and press the Return key.

If you don’t know the name of a city but know where it is, you can find it by clicking its location on the map. Each blinking point is a location in the list. If you click in the map and then drag to a blinking point, that location’s name, latitude, longitude, and time zone appear.

(If you hold down the Option key while clicking the Find button, Map displays, one at a time, all the locations in its list.)

Adding or removing a location

Adding a location

- 1. If the map does not show the location you want to add, scroll by dragging beyond the map in the direction of the location.**
 - 2. Click the location.**
- A blinking star appears at the location, and its coordinates and approximate time zone are displayed.
- 3. Type the name of the new location.**
 - 4. If you know the coordinates, type them in the latitude and longitude boxes.**

When the N and E boxes are checked, the boxes next to them display North latitude and East longitude, respectively. Otherwise, they display South latitude and West longitude.

- 5. If the time zone is not correct, click the Time Zone boxes and type in the correct number.**

When the box at the end of the Time Zone line is checked, the boxes show how much time the location is ahead (east) of Greenwich Mean Time. Otherwise, they display how much time the location is behind (west of) Greenwich Mean Time.

The map estimates the time difference based solely on longitude. Since the boundaries and time of time zones are determined politically, you may need to consult a time zone chart, map, atlas, or globe for the correct time.

- 6. Click the Add City button.**

The new location is added to the list. If your computer beeps, the location is already part of the list.

To change details about a location, you need to remove it and then add it again.

Changing or removing a location

- 1. Find a location.**
- 2. Click the Remove City button.**

If you want to keep the location but change the coordinates or time zone, type the new coordinates or time zone, then click the Add City button.

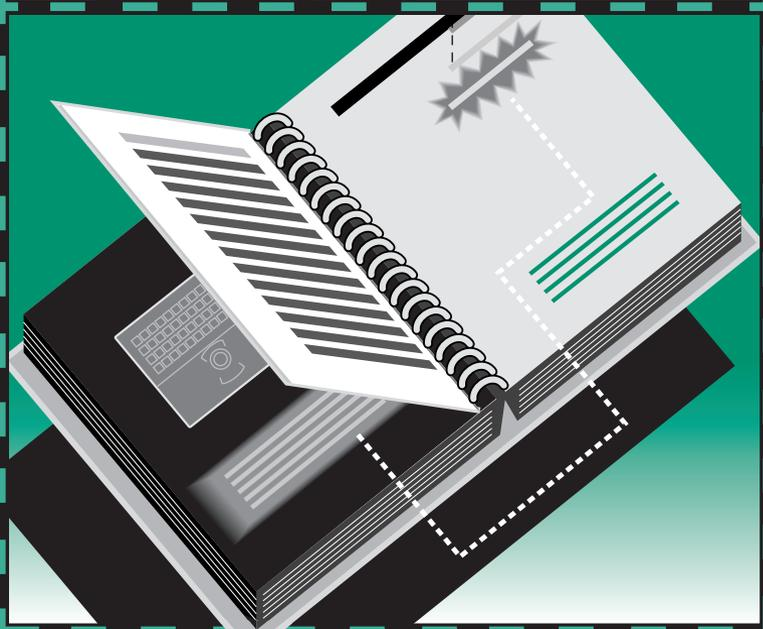
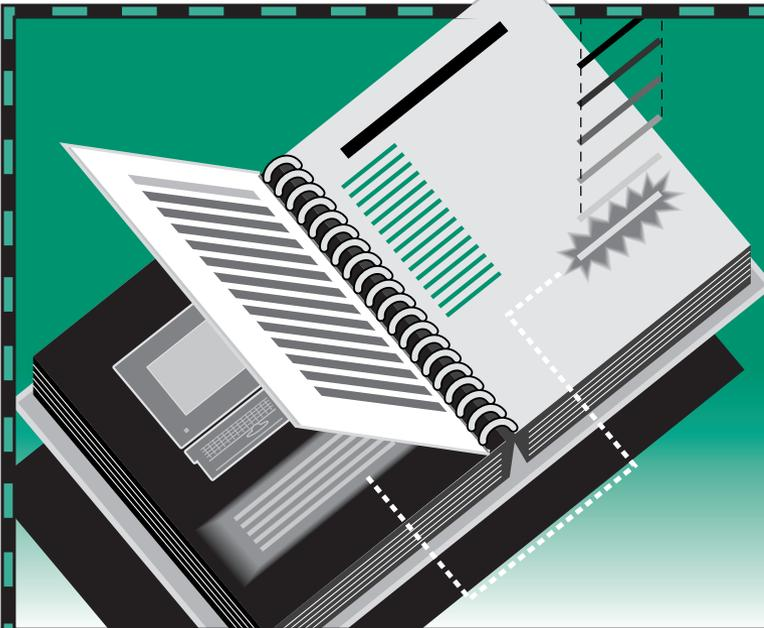

Index

A

About This Macintosh command 161, 164, 231
accent marks, typing 260–261
access privileges. *See also* file sharing; guests; network; passwords
 checking 217
 icons and 217
 restricting 201, 207–208
 set by others 217
 setting 214–215
 strategies for using 215–216
 turning off 209–210
 types of 213–214
active programs 58–62
 identifying 95
active window 42–46
 printing contents of 179
ADB. *See* Apple Desktop Bus (ADB)
air travel tips 233–234
Alarm Clock 149–150
 setting date and time with 149

aliases
 connecting to shared disks with 196
 creating 134
 locating original of 135
 locking 118
 searching for 139
 troubleshooting 134–135
 uses for 134
amplifiers 230
APDA (Apple Programmers and Developers Association) 238
AppleCare Service Agreement 236
Apple Communications Library 237
Apple Desktop Bus (ADB) 7, 229
Apple Developer Programs 238
Apple File Exchange
 converting files with 265–267
 initializing disks with 263–264
Apple HDI-30 SCSI System Cable 224, 227, 266
Apple HD SC Setup program 113–114, 127, 130

Apple menu. *See also* control panels; desk accessories (DAs)
 adding items to 92, 135, 146
 aliases and 134
 pulling down 38
 removing items from 135, 146
 troubleshooting 135
Apple Menu Items folder 146
AppleShare extension 161
AppleShare icon 193–194
AppleShare PC program 266
AppleTalk
 choosing printers and 174, 175
 installing 192
 memory management and 161
 sleep and 192
 turning on/off 191–192
AppleTalk Remote Access 161
AppleTalk zones 175
Apple Technical Library 236
Apple II ProDOS file format 263, 265

- Application menu
 - hiding and showing windows 96
 - making open program active 59–60
 - programs listed in 96
 - switching programs 96
- application programs. *See also* programs
 - installing 92
 - locating 139
 - making active 59–60
 - overview 61
 - PowerBook 145B Backup program 6, 8, 10–12, 119–122
 - PowerBook 145B Restore program 8, 119, 123–125
 - switching 96
 - troubleshooting 92, 257–258
- arrow keys 53, 244, 259
- arrow pointer 36, 249. *See also* arrow keys; I-beam pointer

B

- background pattern, changing 168–170
- background printing 175, 180, 181, 248
- backing up
 - floppy disks 119
 - hard disk 6, 8–12, 119–122
 - individual files 119
 - travel and 233
 - updating a backup copy 121–122
- backup programs 6, 8, 10–12, 119–122
- Balloon Help 87–88, 176
- battery. *See also* power management
 - disposing of 107
 - low power messages 102–103, 108
 - maximizing life of 108
 - maximizing work time with 109
 - monitoring charge level of 86, 101–103
 - power adapter and 2
 - power conservation 87, 109–112, 248, 254
 - processor cycling and 112
 - processor speed and 111
 - recharging 102–106, 108, 235, 248
 - removing or replacing 106–107
 - safety tips for 26, 28, 107
 - sleep and 14, 110, 111
 - storing 234, 235
 - transporting 26, 233
 - troubleshooting 247–248
 - using computer without 106

- Battery Conservation settings 87, 109–112, 248, 252
- Battery desk accessory 86, 101–103
- battery recharger 105–106
- beep sound
 - choosing 165
 - installing 166
 - recording 167–168
 - removing 147, 166
- Berkeley Macintosh User's Group (BMUG) 237
- binary translation 265
- bitmap fonts 182–183
- blinking icons 91, 117, 181, 250
- blinking line (insertion point) 57, 62, 157
- blinking rate 157
- Boston Computer Society 237
- brightness control 5, 7, 32, 109, 245, 249
- bulletin boards 94, 216
- By Label option 142

C

- cables
 - network 191
 - safety instructions 26
 - for SCSI connections 224, 226–227
- cache, disk 162, 250
- capitalization. *See* case sensitivity
- Caps Lock key 259, 260
 - passwords and 195
 - waking computer and 13, 14, 19, 110
- care instructions
 - computer 26–28
 - floppy disks 79
 - hard disks 127
- carpal tunnel syndrome 30
- carriage returns 57
- case, computer 27
- case sensitivity
 - passwords and 204
 - registered user names and 194, 203
- CD-ROM disc
 - access privileges for 215
 - ejecting 126
 - selecting for sharing 201–202
- character repeat rate, adjusting 155
- character sets 259–261
- Chooser 173–175, 191–192
- cities. *See* Map control panel
- cleaning the computer 28, 32
- Clean Up command 40, 131
- Clear command 98
- clicking 37, 39. *See also* double-clicking;
shift-clicking
- Clipboard 64
- clock, setting 148
- close box 48, 49
- CloseView control panel 170–172
 - control panels 170–172
- Close Window command 50, 79
- cold, computer use and 28
- colon (:), in icon names 70
- color documents, printing 179
- comfort tips 31–33
- Command key 53, 67, 244, 259
 - ejecting disks with 126
 - startup scan and 117
 - undoing last action with 258
- commands
 - choosing 40
 - keyboard shortcuts for 66, 244
- computer viruses 94–95, 247
- connectors, safety tips for 27
- contrast control 5, 7, 32, 245, 249
- Control key 53, 259
- control panels
 - appearance of Finder windows 158
 - background pattern 168–170
 - battery conservation 86–87, 109–112, 248, 252
 - beep sound 165
 - blinking rate 157
 - CloseView control panel 170–172
 - currency formats 153
 - Date & Time control panel 148–149, 151–152, 269
 - disk cache 162
 - Easy Access control panel 156
 - file sharing 200–201, 203–205, 207, 208, 211–212
 - guest access 200–201
 - Keyboard control panel 155
 - Labels control panel 148
 - magnifying screen images 170–172
 - Map control panel 269–272
 - Memory control panel 99–100, 109, 162–164
 - modem selection 228
 - monitoring file sharing 210–211
 - Mouse control panel 154
 - network identity 192, 200, 209–210, 212–213
 - Numbers control panel 153
 - passwords 192, 204, 212–213
 - processor cycling 112
 - program linking 220, 221–222
 - Sharing Setup control panel 192, 200, 209–210, 212–213, 220
 - sleep 110–111
 - Sound control panel 165–167
 - Startup Disk control panel 116

- 32-bit addressing 164
- time 148–149, 269
- trackball speed 154
- troubleshooting and 247
- Users & Groups control panel 200–201, 203–205, 207–208, 211–212, 221
- Views control panel 142, 158
- virtual memory 163–164
- Copy command 98
- copying. *See also* backing up
 - disks 78–79, 82–83, 119, 125
 - documents 69–70, 253
 - files without a floppy disk drive 92
 - icons 240
 - items to and from Scrapbook 98
- copyright law, file sharing and 202
- crashes 17–18, 246
- creating
 - aliases 134
 - documents 57
 - folders 132
 - folders on shared disks 197
 - RAM disk 99–100
 - stationery 140–141
 - virtual memory 163–164, 231
- currency formats, changing 153
- cursor. *See* arrow pointer; insertion point
- Cut command 64, 166

D

- damage to computer 235, 247
- DAs. *See* desk accessories (DAs)
- Date & Time control panel
 - changing date format 151
 - changing time format 152
 - Map control panel and 269
 - setting date and time 148–149
- DCA-RFT/MacWrite translator file 265
- dealer support 235–236
- Delete key 57, 259
- deleting
 - files 71–72, 253
 - Scrapbook items 98
 - text 63–64
 - typing errors 57
- deselecting an item 39
- desk accessories (DAs)
 - Battery 86, 101–103
 - Chooser 173–175, 191–192
 - Key Caps 186, 260–261
 - switching between 96
- desktop
 - changing background pattern 168–170
 - Clean Up Desktop command 40
 - contents of 16, 50–52
 - dragging an object on 39
 - hiding and showing windows on 96
 - moving an item to 135
 - pointing to an object on 36
 - printing contents of 179
 - selecting an object on 37
 - startup and 5, 16
 - straightening up 131
 - VM Storage file 164
- development tools 238
- device drivers 224, 249
- diacritical marks, typing 260–261
- dimmed icons 96
- directory dialog box 133, 244
- disk cache 162, 250
- diskettes. *See* floppy disks
- Disk First Aid 18, 127, 128–129
- disk repair programs 18, 125, 129
- disks. *See* CD-ROM disc; floppy disks; hard disk; RAM disk; shared disks; startup disk
- Disk Tools* disk
 - Apple HD SC Setup program 113–114, 127, 130
 - Disk First Aid 127, 128–130
 - initializing hard disk with 113
 - PowerBook 145B Restore program 123
 - restarting with 18
- display. *See* screen
- Document Content Architecture (DCA)
 - format 265

documents. *See also* files
aliases for 134–135
automatic updating of 190
changing name of 70–71
changing text in 62–65, 66–68
closing 60, 69
converting to and from MS-DOS
format 265–267
converting to and from stationery
140–141
copying 69–70, 253
creating 57
deleting 71–72, 253
labels for 142
making document window active 59, 69
naming 57–58, 133
opening 61–62, 69
opening automatically 146
organizing 131
overview 52
printing 178–179, 181
saving 57, 133, 253
saving as templates 140–141
saving changes in 65
transferring 143
“Don’t sleep when plugged in”
option 111, 248
DOS, exchanging files with 263–267

double-clicking 239. *See also* clicking;
shift-clicking
adjusting speed of 154
icons 62, 96
selecting text by 68
double-sided floppy disks 74, 75.
See also floppy disks
downloading printer fonts 184–185
Download PostScript File command 188
dragging
objects 39
size box 44–45, 47
title bar 49
drivers 224, 251
drop boxes 216
Duplicate command 70
duplicating. *See* copying

E

Easy Access control panel 156
Easy Install dialog box 93
editing documents 62–65
Edit menu
Clear command 98
Copy command 98
Cut command 64
Paste command 64, 98
Quit command 68
Undo command 258

ejecting a floppy disk 80, 126
electrical safety tips 26
electronic bulletin boards 94, 216
elevation feet 7, 32
Empty Trash command 72, 100
turning off warning 160
Enter key. *See* Return key
Erase Disk command 100, 116
erasing
floppy disks 116
RAM disk 100
typing errors 57
ergonomics. *See* comfort tips
error messages
printing 180
“system error” 17
Ethernet cables 191
Extensions folder
AppleShare file 194
File Sharing icon 192
Network icon 192
troubleshooting and 247
external battery recharger 105–106
external hard disk 117
external microphone 7, 167, 230
external modems 228, 254
external monitors 104
Extras folder 182

F

fax/data modem 228

file exchange 263–267

File menu

Close Window command 50, 79

Download Fonts command 185

Download PostScript File command 188

Duplicate command 70

Find Again command 136

Find command 136–139

Get Info command 97, 118, 141

Initialize Printer's Disk command 186

Make Alias command 134, 196

New Folder command 132

New Group command 204

New User command 203

Open command 41

Page Setup command 176–178

Preferences command 181

Print command 178–179

Print Desktop command 179

Print Window command 179

Put Away command 80, 126, 195

Save command 57–58, 65–66

Sharing command 199, 201–202, 206, 209, 214–215

files. *See also* documents; file sharing; System Folder; system software

adding to System Folder 146–147

aliases for 134–135

backing up 8–12, 119–122

closing 60, 69

converting to and from MS-DOS
format 265–267

copying 69–70, 253

deleting 71–72, 253

getting information about 141

labels for 142

locating 134–135, 136–139

locking and unlocking 118, 253

naming 133

opening 61–62, 69

opening automatically 146

organizing 131

overview 51–52

program versus document 51–52

RAM disk and 99

removing from System Folder 147

restoring from backup copies 123–125

saving 57, 133, 253

straightening up 131

transferring 143

file servers 193, 194, 266

file sharing 190, 199–212. *See also* access
privileges; guests; network

access privileges for 201, 213–215

ceasing to share a folder 202

changing ownership of a folder 197, 199,
209, 213

changing your password 197–198,
212–213

checking access privileges 217

copyright laws and 202

creating a shared folder 197

disconnecting someone from your
computer 211

giving away ownership of folders or
disks 209

memory management and 161

monitoring 210

naming users and groups for 203–205

passwords for registered users 204

preventing access to your disk 207–208

reconnecting to shared disks 209

removing users or groups 208

selecting folders or disks to
share 201–202

selecting users or groups for
sharing 206–208

sharing your own files 199–202

taking back shared folders or disks 202

turning off 207–208, 209–210

turning on 200

turning on guest access 200–201

viewing names of group members 205

File Sharing icon 192

File Sharing Monitor 210–211

file translators 263, 265

Find Again command 136

Find command 136–139

Find dialog box 136–139

Finder

- changing appearance of windows in 158
 - checking memory use in 161, 231
 - keyboard shortcuts in 244
 - making active 58–60
 - overview 61
 - printing and 178
- fixed-size (bitmap) fonts 183
- floppy disk drive
- illustration 7
 - inserting disks into 24, 74
 - removing disk from 80, 126
 - restarting with 18
 - starting up with 117
 - troubleshooting 125, 126, 252, 253
- floppy disks
- backing up contents of 119
 - for backing up the hard disk 9, 10, 113, 119–122
 - capacities of 74, 75
 - caring for 79
 - copying contents of 78–79, 82–83, 119
 - double-sided 74, 75
 - ejecting 80, 126, 252
 - erasing 116
 - file sharing on 201
 - high-density 9, 74, 75, 81, 252
 - initializing 76–77, 115, 253
 - initializing in MS-DOS format 263–264
 - inserting 11, 24, 74

- installing system software from 93–94
- labeling 12
- locking and unlocking 81, 117, 122
- obtaining 73
- repairing 18, 119
- restarting from 18
- for restoring the hard disk 123–125
- starting *Macintosh Basics* tour
 - from 20, 24
- transferring files with 143
- troubleshooting 125, 126, 128–129, 252–253
- types of 74, 75
- viruses and 94–95

folders. *See also* file sharing; System Folder

- access privileges to 214–215
 - aliases for 134–135
 - Apple Menu Items folder 146
 - ceasing to share 202
 - changing ownership of 197, 199, 209, 213
 - creating and naming 132
 - locking 118
 - opening 79
 - opening higher-level folder windows 241
 - organizing files in 51, 132
 - sharing 201–202, 257
 - Startup Items folder 92, 146
 - viewing contents of 242
- Font menu 186

fonts

- bitmap (fixed-size) 182–183
 - displaying available fonts 186
 - downloading to a printer 180, 184–185
 - font families in suitcases 183, 184
 - installing 183
 - Key Caps program and 186, 260–261
 - LaserWriter Font Utility program 184, 186–188
 - outline (scalable or variable-size) 182
 - PostScript 184–185
 - removing 147, 184, 187
 - troubleshooting 180, 255
 - TrueType 182
 - types of 182–183
 - in views 158
- Fonts folder 182, 186
- formats
- date 151
 - file exchange 263–265
 - number and currency 153
 - time 152
- formatting. *See* initializing
- fragmented memory 161

G

- General Controls control panel 157, 168–170
- General Controls panel
 - adjusting blinking rate 157
 - changing background pattern 168–170
 - setting time and date 149
- Get Info command 97, 118, 141
- graphics tablets 154
- gray-scale documents, printing 179
- groups, network. *See* registered group
- guests. *See also* file sharing; network; passwords
 - access privileges of 193, 194, 200–201, 215
 - connecting to a shared disk as 194, 196
 - denying access to 207–209
 - folder ownership of 197
 - program linking and 219, 220, 221
 - registered groups and 205
 - removing from a group 208
 - turning on 200–201, 202

H

- hard disk. *See also* shared disks
 - access privileges for 214–215
 - backing up 6, 8–12, 119–122
 - battery consumption and 101, 104
 - capacity of 75
 - caring for 127

- connecting to a printer 186
 - damage symptoms 113
 - deleting items from 71–72
 - designating as startup disk 116
 - external 117
 - finding items on 136–139
 - hard disk sleep 111
 - initializing (formatting) 76, 113–114
 - initializing printer 186
 - installing programs on 78–79, 82–83, 92, 94
 - overview 51, 75
 - reinstalling system software on 91, 93–94
 - restoring from a backup copy 8, 12, 123–125
 - safety tips for 27, 127
 - scanning order at startup 117
 - starting *Macintosh Basics* tour from 20–23
 - as startup disk 16, 116–117
 - testing and repairing 127–130
 - transferring files from 143
 - troubleshooting 18, 114, 127–130, 251–252
 - virtual memory and 163–164
- hard disk icon 41, 51, 75
 - failure to appear 127–128
 - opening 41
 - removing from desktop 126
 - hardware development support 238

- HDI-30 SCSI System Cable 224, 226–227
- headphones, connecting 230
- health concerns 29–33
- heat
 - batteries and 28, 103
 - troubleshooting 246
- Help 87–88, 176
- Help menu
 - Hide Balloons command 88
 - Page Setup options and 176
 - Show Balloons command 87, 176
- hidden windows, viewing 96
- Hide Balloons command 88
- Hide Others command 96
- high-density floppy disks 9, 74, 75, 81, 252.
See also floppy disks
- highlighting text 63–64
 - by double-clicking 68
 - with Shift key 67
- horizontal scroll bar 47–48

I

- I-beam pointer 62–63, 249. *See also* arrow pointer
- icons
 - access privileges and 217
 - alias 134
 - arrangement of 131, 158
 - blinking 91, 117, 181, 250
 - changing appearance of 159–160
 - changing names of 70–71

- copying 240
- of currently active program 60
- dimmed 96
- double-clicking 62
- dragging 39
- ejecting disks with 126
- highlighting 37
- labels for 142
- moving 135, 240
- opening 41, 63, 240
- organizing 131, 132
- overview 50–52
- pointing to 36
- pressing 38
- question mark 91, 117
- Quick Reference 239–240
- renaming 240
- selecting 37, 239
- of shared folders you own 197
- size of in views 158
- types of 50–52, 75

ID numbers. *See* SCSI ID numbers

ImageWriter

- Page Setup options for 176
- troubleshooting 180

Info window

- adjusting program memory 97
- changing an icon 159–160
- creating stationery 140–141

- getting information about a file 141
- locating original of an alias 135
- locking a file 118

Initialize Printer's Disk command 186

initializing

- disk repair and 129
- floppy disks 76–77, 115, 253
- floppy disks in MS-DOS file format 263–264
- hard disk 76, 113–114

injuries 30

inserting text 57, 62–63

insertion point 57, 62

- adjusting blinking of 157
- positioning 63

Inside Macintosh 237

Install disk 93

Installer program, printer software update with 177–178

installing

- Apple menu items 135, 146
- AppleTalk software 192
- application programs 92
- CloseView control panel 170–172
- device drivers 224
- fonts 183
- printer software 174, 175
- programs 78–79, 82–83, 92
- sounds 166

- System Folder items 146–147
- system software 91, 93–94
- without a floppy disk drive 92

internal modems 228–254

interrupt button 7, 17

J,K

keyboard. *See also* mouse; trackball

- adjusting response of 155
- arrow keys 53, 244
- comfort tips 31–32
- layout and key functions 259–261
- modifier keys 53, 66, 156
- Slow Keys feature 156

Keyboard control panel 155

keyboard files 147

keyboard shortcuts

- CloseView 171
- ejecting disks 126
- outline view 242
- overview 66
- Quick Reference 244
- Quit command 68
- Save command 66
- selecting text 67
- Sticky Keys feature 156
- turning on and off 172

Key Caps desk accessory 186, 260–261

kilobyte (K) 75

L

- labeling floppy disks 12
- Label menu 139, 142, 148
- labels, file 142
- Labels control panel 148
- LaserWriter. *See also* fonts; printers
 - background printing with 181
 - choosing 174
 - connecting 229
 - downloading fonts to 184–185
 - fonts available for 186
 - Page Setup options for 176
 - printing on 178–179
 - restarting 187
 - selecting in Chooser 174
 - transferring PostScript file to 188
 - turning start page on or off 187
- LaserWriter Font Utility program 184, 186–188
- licensing agreements
 - file sharing and 202
 - software installation and 92
- lightning bolt icon 104
- linking programs 218–222
- list views 142, 158, 242
- LocalTalk cables 191
- locked files, searching for 139
- locking
 - aliases 118
 - files 118, 253
 - floppy disks 81, 117, 253
 - folders 118

- log files, printer 188
- long-term storage 103, 235
- low-power input devices 229, 247
- low-power messages 102–103

M

- Macintosh Basics* tour
 - finding 20
 - starting from floppy disk 20, 24–25
 - starting from hard disk 20–23
 - versus book's tutorial 19
- Macintosh desktop computer, connecting to 199
- Macintosh HD icon, opening 41, 78
- Macintosh user groups 237
- MacWrite format, converting to and from 265
- magnifying screen image 170–172
- maintenance instructions 26–28
- Make Alias command 134, 196
- malfunctions, computer 235
- Map control panel 269–272
- megabyte (MB) 75
- member of a group. *See* registered group
- memory. *See also* RAM disk; random-access memory (RAM); virtual memory
 - adding 231
 - AppleTalk and 161
 - checking use of 97, 161, 231

- disk cache and 162, 250
- fragmentation of 161
- management tips 161–162
- programs' use of 97, 161–162
- system sleep and 111
- 32-bit addressing 164
- troubleshooting 245–258, 250
- using hard disk space as
 - memory 163–164
- Memory control panel
 - disk cache size 162
 - RAM disk 99–100
 - 32-bit addressing 164
 - virtual memory 109, 163–164
- menu bar 16
- menus
 - adjusting blinking of items in 157
 - choosing items from 243
 - commands in 40
 - keyboard shortcuts 66
 - overview 52
 - pop-up 243
 - pull-down 38, 242
 - Quick Reference 242–244
 - submenus 243–244
 - titles (names) of 16
 - viewing 38
- microphone 7, 167, 230
- modem port 7, 174, 228, 248

modems

- connecting internal and external 228
- power consumption of 109, 247
- selecting internal/external 228
- transferring files with 143
- troubleshooting 254
- viruses and 95

modifier keys

- overview 53, 66. *See also* keyboard shortcuts
- Sticky Keys feature for 156
- typing special characters with 260–261

monitors, external 104

mouse. *See also* trackball

- adjusting response of 154
- comfort tips for 32
- connecting 229

Mouse control panel 154

moving

- icons 135, 240
- text 64
- windows 49–50, 240

MS-DOS file format

- converting to and from 265–267
- initializing disks in 263–264

multiple programs 95–96

N

naming

- documents 57–58, 70–71, 133
- folders 132
- icons 70–71, 240
- registered groups 204–205
- registered users 194, 203
- your Macintosh 192

network. *See also* access privileges; file

- sharing; guests; passwords;
- shared disks

accessing your own computer

- on 211–212, 257

advantages of 189–190

AppleTalk and 191–192, 194

assigning access privileges 213–215

assigning passwords to users/groups 204

ceasing to share a folder or disk 202

changing your own password 197–198, 212–213

checking your access privileges 217

connecting to 191

connecting to a shared disk 193–197

converting MS-DOS files on 266

creating bulletin boards on 216

disconnecting from a shared disk 126, 195

disconnecting users from your computer 211

installing programs from 92

linking programs 218–222

monitoring file-sharing activity 210

naming registered groups 204–205

naming registered users 203–204

naming your computer and its owner 192

ownership of folders/disks 197, 199, 209, 213

preventing access to your computer 207–208

removing items from System Folder on 147

removing users/groups from list of registered users 208

selecting a folder or disk to share 201–202

selecting a user/group for sharing 206

setting up your computer 190–192

shared disk icons 51

sharing your own files 199–202

sleep and 110, 192, 248

technical information on 237

transferring files over 143

troubleshooting 212, 254, 255, 256–257

turning file sharing off 207–208, 209–210

turning file sharing on 200

updating printer software on 177–178

viewing group members 205

viruses and 95

working with files and folders 197–199

network administrator 190, 193, 197, 198
Network icon 192
network printers. *See also* printers
 choosing 174–175
 troubleshooting 254, 255
 updating software for 177–178
network software, removing from System
 Folder 147
network zones 175, 193, 194, 254, 256
new folder, creating 132, 197
New Group command 204
New User command 203
nickel-cadmium (NiCad) batteries. *See* battery
number formats 153
Numbers control panel 153

O

Open command 41
opening
 the computer display screen 3
 documents 61–62, 69, 146
 folders 79, 241
 icons 41, 63, 78, 240
 programs 56, 69, 146
operating system. *See* system software
Option key 53, 259
 Clean Up command and 131
 Empty Trash warning override 160
 typing accent marks with 261

organizing files 131–135
outline form in list views 242
outline (scalable or variable-size) fonts 182
out-of-paper signal 181
owner icon 197, 205
owner password 192

P

Page Setup options 176–178, 180
passwords
 assigning to others 204
 case sensitivity of 204
 changing your own 197–198, 212–213
 troubleshooting 195
 typing 192
Paste command 64, 98, 166
pattern, background 168–170
peripheral devices. *See also* printers
 Apple Desktop Bus (ADB) devices 229
 external hard disks 117
 external monitors 104
 headphones 230
 microphone 7, 167, 230
 modems 95, 109, 143, 228, 254
 mouse 32, 154, 229
 SCSI devices 223–227
 speakers 230
Personal LaserWriter SC. *See* LaserWriter
plug adapters 234

pointer. *See* arrow pointer; I-beam pointer
pointing to an object 36
ports, safety tips for 27. *See also* modem
 port; printer port
PostScript files, transferring to
 LaserWriter 188
PostScript fonts, downloading 184–185
PostScript log, creating 188
power adapter
 conserving power with 109
 “Don't sleep when plugged in” option
 111, 248
 for external recharger 105
 long-term storage and 235
 plugging in 2
 preventing automatic sleep while
 using 110, 248
 recharging battery with 102, 103–104
 safety tips 2, 27–28, 229
 short-term storage and 234
 for StyleWriter printer 229
 travel tips 234
power adapter port 2, 7
PowerBook 145B Backup program 6, 8,
 10–12, 113, 119–122
PowerBook 145B Restore program 8, 119,
 123–125
PowerBook control panel
 battery conservation 86–87, 110–112,
 248, 252
 “Don't sleep when plugged in” option
 111, 248

- hard disk sleep adjustment 110, 111, 248, 252
- modem options 228
- processor cycling 112
- processor speed 111
- system sleep adjustment 110, 111, 248, 252
- power button 7, 15
 - RAM disk and 18
 - restarting computer with 18
 - “Shut Down” warning 13
 - turning computer on with 4, 15, 19
- power management. *See also* battery
 - Apple Desktop Bus devices and 229
 - battery conservation settings 86–87, 109–112, 247, 248, 252
 - low-power messages 102–103, 108
 - maximizing battery life 108
 - monitoring battery charge level 86, 101–103
 - processor cycling 112
 - RAM disks and 99, 109
 - recharging the battery with power adapter 103–104
 - recharging the battery with recharger 105–106
 - removing or replacing battery 106–107
 - troubleshooting 247
- power problems
 - low battery 102–103
 - troubleshooting 5, 245, 247–248
- power states 13–15
- Preferences command 181
- pressing with the trackball 38
- Print command 178–179
- Print Desktop command 179
- printer port 7, 191, 229, 248
- printers. *See also* ImageWriter; LaserWriter; network printers; StyleWriter
 - choosing 173–175
 - connecting 173, 229
 - downloading fonts to 184–185
 - initializing hard disk connected to 186
 - LaserWriter Font Utility and 186–188
 - out-of-paper signal 181
 - Page Setup options for 176
 - PrintMonitor and 181
 - restarting 187
 - troubleshooting 174, 175, 180, 254–255
 - turning start page on or off 187
 - updating printer software on networks 177–178
- printer software
 - installing 174, 175
 - removing from System Folder 147
 - updating on networks 177–178
- Printer Update document 177
- printing. *See also* fonts
 - background 175, 180, 181
 - choosing printer 173–175
 - color documents 179
 - desktop contents 179
 - documents 178–179, 181
 - error messages 180
 - gray-scale documents 179
 - LaserWriter start page 187
 - on networks 174–175, 177–178
 - Page Setup options 176–178
 - troubleshooting 180, 254–255
 - window contents 179
- PrintMonitor program 181
- Print Window command 179
- problems. *See* troubleshooting
- processor cycling 109, 112, 246, 249, 257
- processor speed 111
- ProDOS file format 263, 265
- program linking
 - allowing guests to link to your programs 221
 - allowing users to link to your programs 219
 - disconnecting 219
 - linking to a program on another computer 218–219
 - registered users and groups and 221–222
 - selecting a program for 220
 - turning on 220

programs. *See also* application programs;
system software

- adding to Apple menu 135, 146
- aliases for 134
- application versus system 61
- for backing up hard disks 8, 12, 119
- copying from floppy disk 78–79, 82–83
- copyright laws and 202
- disk repair 18, 125, 128–129
- Info window and 97
- installing 78–79, 82–83
- installing without a floppy disk drive 92
- linking 218–222
- making active 58–60, 96
- memory use of 97, 161–162
- multiple 95–96
- opening 56, 69
- opening automatically at startup 146
- performance of 92, 112
- quitting 60, 68, 69
- RAM disks and 99, 100
- switching active 58–60, 96
- troubleshooting 92, 257–258
- types of 51, 61

protecting disk contents 81, 117–118

publish-and-subscribe feature 190

Put Away command 80, 126, 195

Q

question mark on Help menu 87–88

question mark startup icon 91, 117

Quick Reference

- icons 239–240
- keyboard shortcuts 244
- menus 242–244
- windows 240–242

Quit command 68

R

RAM. *See* random-access memory (RAM)

RAM disk

- creating 99–100
- erasing 100
- insufficient memory and 250
- low-power messages and 103
- memory recommendations for 99
- power button and 18
- power conservation and 109
- reset button and 17
- resizing or removing 100
- Restart command and 17
- Shut Down and 99

random-access memory (RAM).

See also memory

- adding 231
- checking use of 97, 161, 231
- disk cache and 162, 250
- low-power conditions and 103
- management tips 161–162
- programs' use of 97, 161–162
- RAM disk requirements for 99
- sleep and 110
- 32-bit addressing and 164
- virtual memory and 163–164, 250

recharger, external 105–106

recharging the battery 26, 28, 234–235, 248

recharging times 106

recording sound 167–168

registered group

- access privileges of 213–215, 216
- denying access 207–208
- giving folder or disk ownership to 209
- naming 204–205
- program linking and 221–222
- removing 208
- removing a user from 208
- sharing folders and disks with 206
- viewing members of 205

- registered user
 - access privileges of 213–215, 216
 - changing password of 197–198
 - connecting to a shared disk as 197
 - creating a folder as 197
 - denying access to 207–208
 - disconnecting 211
 - folder ownership and 197, 209
 - naming 203–204
 - passwords for 204
 - program linking and 221–222
 - removing 208
 - sharing your files with 206
 - typing name and password 193, 194, 213
- reinstalling system software
 - from a shared disk 92
 - from floppy disks 91, 93–94
- removing
 - battery 106–107
 - extra System Folders 83
 - floppy disk 80, 126
 - fonts 147, 184
 - guests 208
 - RAM disk 100
 - registered users or groups 208
 - sounds 147, 166
 - System Folder items 147

- repairing computer 27, 245
- repetitive stress injuries (RSIs) 30
- reset button 7, 17, 245
- Restart command 17
- restarting the computer 17–18
 - RAM disk and 100
- Restart Printer command 187
- restoring
 - hard disk 8, 12, 123–124
 - System Folder 125
- Return key 57, 71, 244, 259
- Revisable Form Text (RFT) format 265

S

- safety instructions
 - battery 26, 28, 107
 - floppy disk 79
 - hard disk 27, 127
 - malfunction or damage 235
 - power adapter 2, 27, 28, 104, 229
 - RAM disk 99
 - SCSI devices 227
 - traveling 233–234
 - viruses 12, 94–95
- Save As command 133, 140

- Save command 57–58, 66, 140
- saving
 - in a directory 133
 - changes 65
 - documents 57–58, 133, 253
 - documents as templates 140–141
 - and quitting 68
- scalable fonts 182
- scanning order for startup disks 117
- Scrapbook 98
- screen
 - background pattern, changing 168–170
 - battery and 101, 104, 109, 249
 - brightness control 5, 7, 32, 109, 245, 249
 - cleaning 28, 32
 - comfort tips 32
 - contrast control 5, 7, 32, 245, 249
 - external monitors 104
 - magnifying image on 170–172
 - opening 3
 - position of 3, 249
 - power consumption of 109
 - safety tips for 28
 - troubleshooting 5, 19, 245, 249
 - waking from sleep 13, 14, 19, 110
- scroll bars 47–48

- SCSI cables 224, 226, 227
- SCSI chains 128, 226–227
- SCSI devices
 - connecting 227, 229
 - ID numbers for 114, 128, 224–225
 - installing software for 224
 - overview 223–224
 - terminators for 128, 226, 227
 - troubleshooting 250–251
- SCSI icon 223, 227
- SCSI ID numbers 114, 128, 224–225
- SCSI port 7, 223, 227
- SCSI terminators 128, 226, 227
- searches 136–139
- selecting an icon 37, 40–41
- selecting text 63–64, 67–68
- service locations 235–236, 245
- setting up computer 1–6. *See also* peripheral devices
 - on a network 190–192
- shared disk icons 51, 196
- shared disks. *See also* access privileges; file sharing; network
 - accessing files on 197–202
 - access privileges for 213–215
 - aliases for 134, 196
 - belonging to you 199–202
 - ceasing to share 202
 - changing ownership of 209
 - changing your password 197–198, 212–213
 - connecting to 193–197
 - creating new folders on 197
 - disconnecting from 126, 195
 - folder ownership on 197, 199, 209, 213
 - preventing access to your computer 207–208
 - reconnecting to 209
 - selecting a disk to share 201–202
 - sleep and 110, 248
 - troubleshooting 194, 256–257
- shared files. *See* file sharing
- Sharing command 199, 201–202, 206, 209, 214–215
- Sharing Setup control panel
 - changing your password 212–213
 - identifying your computer on a network 192
 - turning file sharing off 209–210
 - turning file sharing on 200
 - turning program linking on 220
- shift-clicking 67, 239. *See also* clicking; double-clicking
- Shift key, system extensions and 247
- short-circuiting battery 26
- shortcuts. *See* keyboard shortcuts
- short-term storage 234
- Show All command 96
- Show Balloons command 87
- Shut Down command 13
 - RAM disk and 99, 100
- size box 44–45, 46–47
- size of window, changing 44–45, 58, 240
- sleep
 - AppleTalk and 192
 - automatic 14, 103, 110, 111
 - battery conservation settings and 110–111, 252
 - hard disk sleep 111
 - low-power messages and 103
 - networks and 110, 192, 248
 - power states and 15
 - preventing 110, 192, 248
 - putting the PowerBook to sleep 14
 - startup process and 16
 - system sleep 111
 - travel and 233
 - troubleshooting and 246, 248
 - waking the computer from 13, 14, 15, 19
 - when to use 14, 109
- Sleep button 102

- Sleep command 14, 99
- Slow Keys feature 156
- Small Computer System Interface.
 See SCSI *entries*
- software. *See* application programs;
 programs; system software
- software development support 238
- software drivers 224, 251
- software licensing agreements 92, 202
- Sound control panel 165–167
- sound input port 7, 167, 230
- sound output devices 230
- sound output port 7, 230
- sounds. *See also* microphone
 - alarm clock 149–150
 - choosing 165
 - installing 166
 - recording 167–168
 - removing 147, 166
 - setting volume of 165
- Slow Keys alert 156
- speakers 7, 230
- special characters, typing 260–261

- Special menu
 - Clean Up command 40, 131
 - Eject Disk command 126
 - Empty Trash command 72, 100
 - Erase Disk command 100, 116
 - Restart command 17
 - Shut Down command 13
 - Sleep command 14
- start page, LaserWriter 187
- startup
 - from floppy disks 18
 - opening items automatically at 146
 - scanning order for 117
 - troubleshooting 5, 17–18, 245
- startup disk
 - conserving power with 164
 - designating 116
 - installing system software on 91
 - overview 16, 75
 - scanning order for 117
 - System Folder on 83, 91, 164
 - troubleshooting 91, 127–128, 245, 247
 - virtual memory and 164
- Startup Disk control panel 116
- startup disk icon 16

- Startup Items folder 92, 146
- stationery, creating 140–141
- Sticky Keys feature 156
- storing items in Scrapbook 98
- storing the computer 103, 234–235
- StyleWriter
 - background printing with 181
 - power adapter caution 229
- submenus 243–244
- suitcases, font 183, 184
- support services 235–236
- symbols, typing 260–261
- System 7 software, networks and 199
- system crashes 17, 246
- system error, restarting after 17–18
- system extensions 161, 247

- system failures 247
- System Folder. *See also*
 - folders
 - backing up 8, 10–12, 120–122
 - Extensions folder 192, 194, 247
 - Find command and 136
 - Fonts folder 182, 186
 - installing files in 146–147
 - installing fonts in 182, 183
 - installing sounds in 166
 - listing fonts in 186
 - on program disks 83
 - on startup disk 83, 91, 164
 - removing extra System Folders 83, 92, 247
 - removing files from 147, 166
 - removing fonts from 184
 - removing sounds from 166
 - restoring 8, 125
 - viruses and 12, 95
 - VM Storage file in 164
- system sleep 111
- system software
 - installing from floppy disks 93–94
 - overview 8, 61
 - publish-and-subscribe feature 190
 - reinstalling 91, 93–94
 - technical guide to 237
 - troubleshooting 247
 - viruses and 12, 95

T

- Tab key 244, 259
- TeachText program 56
- technical information 237
- technical support 235–236
- telephone lines, transferring files over 143
- telephone numbers, service 236, 245
- temperature
 - batteries and 28, 103, 108
 - computer use and 28
 - storing computer and 103, 234, 235
- templates, creating 140–141
- terminators, checking SCSI 128, 226, 227
- text
 - changing 62–68
 - deleting 63–64
 - inserting 57, 62–63
 - moving 64
 - replacing 67–68
 - selecting 63–64, 67–68
 - typing 57
- text translation 265
- 32-bit addressing 164
- 3.5-inch disks. *See* floppy disks

- time
 - automatic reset during travel 269
 - changing format of 152
 - setting Alarm Clock 149–150
 - setting system clock 148–149
 - tracking time zones 269–271
- title bar 44, 49
- TokenRing cables 191
- trackball. *See also* mouse
 - adjusting 154
 - buttons 36
 - choosing a command with 40
 - clicking with 37, 39
 - comfort tips 31
 - double-clicking with 62, 68
 - dragging with 39
 - pointing with 36
 - pressing with 38
 - using 36–40
- tracking speed 154
- transferring. *See also* copying
 - files 143
 - PostScript files 188
- translator files 263, 265

Trash

- deleting files with 71–72
 - ejecting a disk with 126
 - emptying 72, 100
 - location of 16
 - purpose of 52
 - retrieving items from 72
 - turning off warning for 160
- travel tips 233–234. *See also* Map control panel
- troubleshooting
- aliases 134–135
 - Apple menu 135
 - application programs 92, 257–258
 - battery 247–248
 - blinking icons 91, 250
 - Chooser 174, 175
 - computer is hot 246
 - computer stops working 246
 - damage to computer 235, 247
 - ejection problems 126
 - floppy disk drive 125, 126, 252, 253
 - floppy disks 125, 126, 128–129, 252–253
 - fonts 180, 255
 - hard disks 18, 114, 127–130, 251–252

- malfunctioning computer 247
 - memory 250
 - modems 254
 - networks 212, 254, 255, 256–257
 - passwords 195
 - power problems 5, 245, 247–248
 - printers 174, 175, 254–255
 - printing 180, 254–255
 - restart problems 17–18
 - screen 5, 19, 245, 249
 - SCSI devices 250–251
 - shared disks 194, 256–257
 - sleep 248
 - startup 17–18, 245
 - startup disk 91, 127–128, 245, 247
 - system crash 17, 246
 - system failures 247
 - system software 247
 - 32-bit addressing 164
 - viruses 12, 94–95, 247
 - windows 250
- TrueType fonts 182
- turning computer off 13, 15, 18
- turning computer on 4, 15, 19, 227, 250
- and automatically connecting to a shared disk 196–197
 - and automatically opening a program 146

U

- Undo command 258
- unlocking
- files 118
 - floppy disks 81, 117, 122
- untitled window 56, 57
- upgrades, memory 231
- user, network. *See* registered user
- user groups, Macintosh 237
- Users & Groups control panel
- accessing your own computer over a network 211–212
 - assigning a password 204
 - denying file sharing access 207–208
 - naming a registered group 204–205
 - naming a registered user 203
 - naming users for program linking 221–222
 - removing a registered group 208
 - removing a registered user from a group 208
 - turning on guest access 200–201
- Utilities menu
- Restart Printer command 187
 - Start Page Options 187

V

- variable-size fonts 182
- vertical scroll bar 47–48
- viewing
 - contents of folders 242
 - contents of windows 42–44
 - hidden contents of windows 46–48
 - hidden windows 96
 - list views 142, 158, 242
 - members of registered group 205
 - menus 38
- View menu 142, 242
- Views control panel 142, 158
- virtual memory. *See also* memory
 - creating 163–164, 231
 - insufficient memory and 250
 - power conservation and 109
- viruses 12, 94–95, 247
- VM Storage file 164

W

- waking the computer 13, 14, 19, 110
- warranty service 27, 236, 245
- windows. *See also* Info window
 - active 42–44, 56–58, 69, 240
 - changing display of Finder 158
 - closing 48, 49–50
 - finding lost 250
 - hiding and showing program 96
 - moving 49–50, 240
 - opening higher-level folder 241
 - opening icons into 41
 - overview 52
 - printing contents of 179
 - Quick Reference 240–242
 - resizing 44–45, 58, 240
 - scrolling through 241
 - straightening items in 131
 - title bar of 44, 49
 - troubleshooting 250
 - untitled 56–57
 - viewing contents of 42, 142, 241–242
 - viewing hidden contents of 46–48
- word wrap 57

X

- X-ray machines 233

Y, Z

- zones, network 175, 193, 194, 254, 256
- zoom box 44–45

The Apple Publishing System

This Apple manual was written and edited on a desktop publishing system using Apple Macintosh computers and QuarkXPress. Proof pages were created on Apple LaserWriter printers and on the QMS Colorscript 100 color printer. Final pages were produced in QuarkXPress and output directly to separated film on PostScript driven imagesetters. Line art and part openers were created with Adobe Illustrator. Cover art was produced with Adobe Photoshop. Screen shots were created and modified with system software, Exposure, SuperPaint, and MacPaint.

Text type is Apple's corporate font, a condensed version of Garamond. Ornaments are custom symbols designed for Apple Computer. Some elements, such as computer voice, are set in Apple Courier, a fixed-width font.

PostScript®, the LaserWriter page-description language, was developed by Adobe Systems Incorporated.