



# Apple Color OneScanner



*User's Manual for the Color OneScanner 600/27 and 1200/30*

 Apple Computer, Inc.

©1996 Apple Computer, Inc. All rights reserved.

Under the copyright laws, this manual may not be copied, in whole or in part, without the written consent of Apple. Your rights to the software are governed by the accompanying software license agreement.

The Apple logo is a trademark of Apple Computer, Inc., registered in the U.S. and other countries. Use of the “keyboard” Apple logo (Option-Shift-K) for commercial purposes without the prior written consent of Apple may constitute trademark infringement and unfair competition in violation of federal and state laws.

Every effort has been made to ensure that the information in this manual is accurate. Apple is not responsible for printing or clerical errors.

Apple Computer, Inc.  
1 Infinite Loop  
Cupertino, CA 95014-2084  
408-996-1010  
<http://www.apple.com>

Apple, the Apple logo, AppleScript, ColorSync, LaserWriter, Macintosh, and PowerBook are trademarks of Apple Computer, Inc., registered in the U.S. and other countries.

Apple Desktop Bus, AudioVision, and Finder are trademarks of Apple Computer, Inc.

Adobe, Adobe Photoshop, and PostScript are trademarks of Adobe Systems Incorporated or its subsidiaries and may be registered in certain jurisdictions.

Helvetica and Times are registered trademarks of Linotype-Hell AG and/or its subsidiaries.

MacDraw is a registered trademark of Claris Corporation.

Convolver is a trademark of MetaTools, Inc.

Kai's Power Tools is a trademark of MetaTools, Inc.

TextBridge is a trademark of Xerox Imaging Systems, Inc.

Simultaneously published in the United States and Canada.

Mention of third-party products is for informational purposes only and constitutes neither an endorsement nor a recommendation. Apple assumes no responsibility with regard to the performance or use of these products.



# Contents



Communications Regulation Information   vii

## **1 Welcome   1**

- System requirements   2
- What you need to know   2
- In this manual   3
- In the appendixes   4

## **2 Setting Up the Scanner   5**

- Unpacking the scanner and accessory kit   6
- Choosing a SCSI cable   6
- Choosing the right location   8
- Carrying the scanner   9
- Apple Color OneScanner at a glance   10
- Locking and unlocking the scanner   11
- Setting the SCSI ID number and termination   12
- Connecting the scanner to your Macintosh   13
- Switching the power on   16
- Important safety information   17
- Where to go from here   17

<b>3</b>	<b>Installing the Scanner Software</b>	<b>19</b>
	About the disks	19
	Installing the scanner software	20
	Installing the plug-in module for use by other applications	22
	Assigning the Xerox TextBridge 30H application to the Dispatcher	23
	Setting up ColorSync	25
	Installing Kai's Power Tools and Convolver	26
	Where to go from here	26
<b>4</b>	<b>Scanning Images</b>	<b>27</b>
	What you can scan	28
	Preparing originals	28
	Removing and replacing the scanner cover	31
	Opening the OneScanner Dispatcher application	32
	How the OneScanner Dispatcher application is organized	33
	Scanning with automatic settings	35
	Saving a scanned image	40
	Assigning a fax application to the Dispatcher	42
	Faxing or printing directly from the scanner	42
	Opening a saved image from an archive	43
	Renaming a saved image in an archive	45
	Printing or faxing a saved image from an archive	45
	Adding your own drag-and-drop applications	47
	Scanning directly into a graphics application	49
	Scanning with custom settings	51
	Changing image size and ruler units	57
	Copyright regulations (USA)	59

<b>5</b>	<b>Editing Scanned Images</b>	<b>61</b>
	Opening a saved image	62
	Image-editing overview	64
	Showing and hiding the palettes	65
	Selecting images	66
	Using the tools to edit an image	68
	Copying, cutting, or deleting a selection	75
	Undoing an action	76
	Zooming in and out	76
	Inverting an image from positive to negative	77
	Adjusting the brightness and contrast	78
	Changing the color balance	79
	Sharpening an image	80
	Resizing an image	82
	Cropping an image	83
	Flipping an image	84
	Rotating an image	85
	Setting the image depth	86
	Setting ColorSync preferences	87
	Changing the way you view an archive	88
<b>6</b>	<b>Scanning Text</b>	<b>89</b>
	Scanning a text document into the TextBridge application	90
	Moving a text image to the TextBridge application	92
	Converting a text image into an HTML document	94
<b>7</b>	<b>Dispatcher Commands</b>	<b>95</b>
	File menu	96
	Edit menu	102
	Image menu	103
	Window menu	107
	Image-editing tools	108

<b>8</b>	<b>Scanner Maintenance</b>	<b>111</b>
	Cleaning the scanner	111
<b>9</b>	<b>Using the Automatic Document Feeder</b>	<b>113</b>
	Setting up the Automatic Document Feeder	113
	Automatic Document Feeder at a glance	116
	Choosing originals to scan	117
	Scanning with the document feeder	118
	Bypassing the document feeder	121
	Clearing paper jams	122
	Maintenance	129
<b>10</b>	<b>Using the Transparent Media Adapter</b>	<b>137</b>
	Setting up the Transparent Media Adapter	137
	Handling film	141
	Inserting film into a film guide for scanning	142
	Scanning with the Transparent Media Adapter	145
	Bypassing the adapter	148
	Maintenance	149
	Troubleshooting	150
	<b>Appendix A Technical Specifications</b>	<b>153</b>
	<b>Appendix B Troubleshooting</b>	<b>155</b>
	<b>Appendix C Assembling a SCSI Chain</b>	<b>159</b>
	<b>Index</b>	<b>167</b>

## Communications regulation information

### FCC statement

This equipment has been tested and found to comply with the limits for a Class B digital device in accordance with the specifications in Part 15 of FCC rules. See instructions if interference to radio or television reception is suspected.

### Radio and television interference

The equipment described in this manual generates, uses, and can radiate radio-frequency energy. If it is not installed and used properly—that is, in strict accordance with Apple’s instructions—it may cause interference with radio and television reception.

This equipment has been tested and found to comply with the limits for a Class B digital device in accordance with the specifications in Part 15 of FCC rules. These specifications are designed to provide reasonable protection against such interference in a residential installation. However, there is no guarantee that interference will not occur in a particular installation.

You can determine whether your computer system is causing interference by turning it off. If the interference stops, it was probably caused by the computer or one of the peripheral devices.

If your computer system does cause interference to radio or television reception, try to correct the interference by using one or more of the following measures:

- Turn the television or radio antenna until the interference stops.
- Move the computer to one side or the other of the television or radio.
- Move the computer farther away from the television or radio.
- Plug the computer into an outlet that is on a different circuit from the television or radio. (That is, make certain the computer and the television or radio are on circuits controlled by different circuit breakers or fuses.)

If necessary, consult an Apple-authorized service provider or Apple. See the service and support information that came with your Apple product. Or, consult an experienced radio/television technician for additional suggestions.

**IMPORTANT** Changes or modifications to this product not authorized by Apple Computer, Inc., could void the FCC Certification and negate your authority to operate the product.

This product was tested for FCC compliance under conditions that included the use of Apple peripheral devices and Apple shielded cables and connectors between system components. It is important that you use Apple peripheral devices and shielded cables and connectors between system components to reduce the possibility of causing interference to radios, television sets, and other electronic devices. You can obtain Apple peripheral devices and the proper shielded cables and connectors through an Apple-authorized dealer. For non-Apple peripheral devices, contact the manufacturer or dealer for assistance.

### **DOC statement**

*DOC Class B Compliance* This digital apparatus does not exceed the Class B limits for radio noise emissions from digital apparatus as set out in the interference-causing equipment standard entitled “Digital Apparatus,” ICES-003 of the Department of Communications.

*Observation des normes—Classe B* Cet appareil numérique respecte les limites de bruits radioélectriques applicables aux appareils numériques de Classe B prescrites dans la norme sur le matériel brouilleur : “Appareils Numériques”, NMB-003 édictée par le ministre des Communications.

### **VCCI statement**

#### 情報処理装置等電波障害自主規制について

この装置は、第二種情報装置（住宅地域又はその隣接した地域において使用されるべき情報装置）で住宅地域での電波障害防止を目的とした情報処理装置等電波障害自主規制協議会（VCCI）基準に適合しております。

しかし、本装置をラジオ、テレビジョン受信機に近接してご使用になると、受信障害の原因となることがあります。

取扱説明書に従って正しい取り扱いをしてください。





# 1

## Welcome



Welcome to the Apple Color OneScanner. With the Color OneScanner and the Apple OneScanner Dispatcher application program, you can

- scan an image or document and save it in a format you can use with compatible graphics and page-layout applications
- print or fax saved images using convenient drag-and-drop icons
- retrieve saved images using thumbnail-view archives
- use the Apple Color OneScanner plug-in module to scan directly into applications compatible with Adobe™ Photoshop plug-ins

## System requirements

The Apple Color OneScanner works with Macintosh computers with the following configurations:

- System software version 7.5 or later
- 68030 or later processor

Scanning and scanned images require significant space on your computer and significant free space on a hard disk.

- You need at least 12 megabytes (MB) of random-access memory (RAM). The OneScanner Dispatcher software requires at least 3 MB of free RAM. The TextBridge OCR software requires at least 4 MB of RAM. If you use the two applications at the same time, these RAM requirements are additive (you need at least 7 MB of available RAM, plus the RAM required by your system). Scanning operations improve with more RAM.
- Your hard disk needs to have at least 20 MB of disk space available.

## What you need to know

If you're new to the Macintosh—or to computing in general—you need to

- read the information that came with your computer
- explore the interactive learning products you received

These materials will explain the basic Macintosh skills you need to have before you set up and use your scanner.

## In this manual

This manual provides step-by-step instructions and reference information for the Apple Color OneScanner and the OneScanner Dispatcher application.

Chapter	Title	Provides information about. . .
1	<b>Welcome</b>	This manual and system requirements
2	<b>Setting Up the Scanner</b>	Assembling and connecting the scanner to your Macintosh computer
3	<b>Installing the Scanner Software</b>	Installing the OneScanner Dispatcher application and related software
4	<b>Scanning Images</b>	Using the scanner and the OneScanner Dispatcher application to scan, save, print, and fax; using drag-and-drop icons
5	<b>Editing Scanned Images</b>	Using the OneScanner Dispatcher application to change your scanned images
6	<b>Scanning Text</b>	Using the OneScanner Dispatcher application to scan text
7	<b>Dispatcher Commands</b>	The software, organized by menus and tools
8	<b>Scanner Maintenance</b>	Basic maintenance procedures
9	<b>Using the Automatic Document Feeder</b>	Installation and use
10	<b>Using the Transparent Media Adapter</b>	Installation and use, including a section on troubleshooting

## In the appendixes

The appendixes provide supplementary information about the Apple Color OneScanner.

Appendix	Title	Provides information about . .
A	<b>Technical Specifications</b>	Technical features of the Apple Color OneScanner
B	<b>Troubleshooting</b>	Diagnosing and correcting problems
C	<b>Assembling a SCSI Chain</b>	Connecting the scanner and other SCSI devices

# 2

## Setting Up the Scanner



This chapter shows you how to set up the Apple Color OneScanner. You'll find instructions for

- unpacking, carrying, and placing the scanner
- connecting the scanner to a Macintosh computer
- plugging in the scanner and switching it on
- safely using your scanner

## Unpacking the scanner and accessory kit

Make sure you have the items shown here.

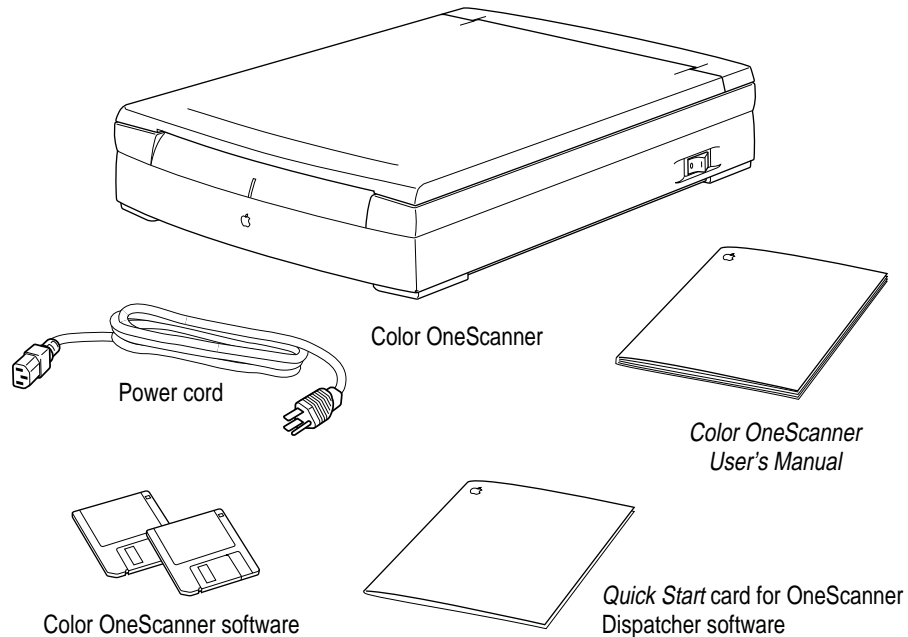

You may have received additional third-party software with your scanner.

## Choosing a SCSI cable

The Apple Color OneScanner connects to your Macintosh through a Small Computer System Interface (SCSI) cable (pronounced “SKUH-zee”). This cable provides for high-speed communication between the computer and a SCSI device, or devices, connected to the computer.

You will need to purchase a SCSI cable to connect your Apple Color OneScanner to the Macintosh. If you have a Macintosh IIx, you also need a special terminator. For more information about connecting the scanner to a Macintosh IIx or PowerBook computer, see Appendix C.

Apple recommends that you purchase only Apple-brand SCSI cables, which are properly shielded for trouble-free operation. You can purchase SCSI terminators and cables from your authorized Apple reseller.

### To connect the scanner directly to the Macintosh

To connect the scanner directly to your Macintosh computer, you need a SCSI system cable.

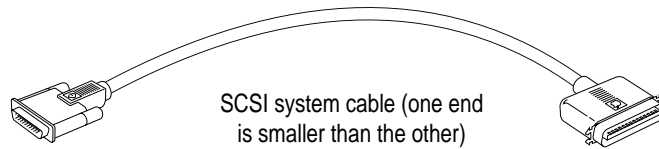

### To connect the scanner at the end of a SCSI chain

If you already have an external SCSI device (such as a SCSI hard disk drive) attached to your Macintosh computer, Apple recommends that you connect the scanner at the end of the SCSI chain.

To make this connection, you need a SCSI peripheral cable.

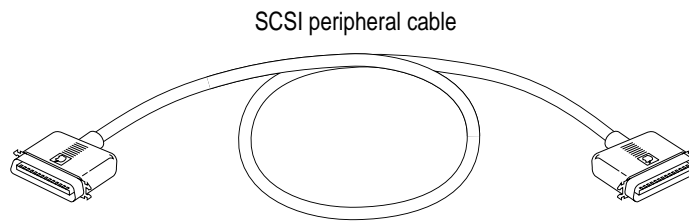

### To use a different arrangement (configuration)

For information about connecting the scanner in the middle of a SCSI chain, see Appendix C, "Assembling a SCSI Chain."

## Choosing the right location

Before you set up the scanner, choose a work area that's convenient for you and that meets the physical requirements of the scanner:

- a level, stable surface, such as a desk or table
- a grounded three-pin power outlet
- space around the scanner for easy access to the on/off switch

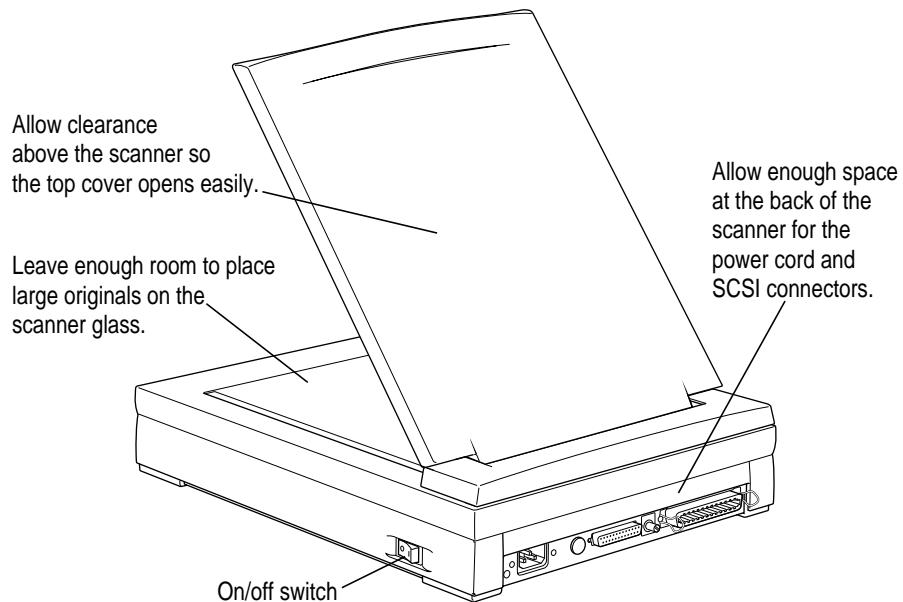

## Environmental considerations

- Make sure you allow space for adequate ventilation so the scanner does not overheat.
- If relative humidity is low, use a humidifier or an antistatic mat to avoid electrostatic buildup. Avoid dusty areas, places where the scanner will be exposed to salty air or corrosive gases, and locations where temperature and humidity levels vary significantly.
- Avoid placing the scanner in direct sunlight or exposing it to open flames.
- Place the scanner on a surface that is free from vibrations.



## Safety precautions

- Don't place the scanner where anyone can walk on the power cord, and do not allow anything to rest on the cord. If you must use an extension cord, be sure the total length of the power cord plus the extension cord is not greater than 16.5 feet (5 meters).
- Keep the scanner away from equipment that might cause electromagnetic or radio frequency interference, such as radio transmitters, cordless telephone base units, television sets, copy machines, and heating and air-conditioning equipment.

## Carrying the scanner

The Apple Color OneScanner is a complex electronic device. Handle the scanner carefully as you set it up.

To carry the scanner:

- 1 Make sure the scanner carriage is locked.**

For information, refer to “Locking and Unlocking the Scanner,” later in this chapter.

- 2 Grasp the scanner by its side edges, toward the back:**

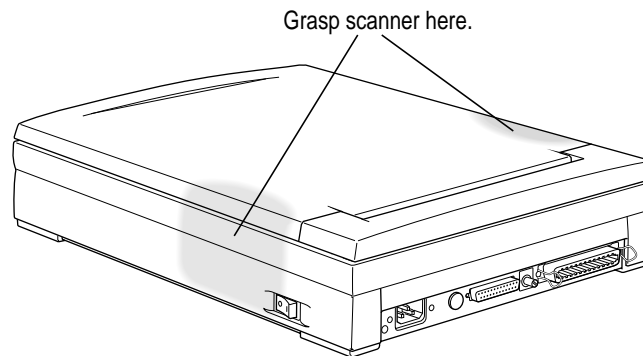

- 3 Carry the scanner flat, without tipping it on its ends or sides, and keep it stable.**

## Apple Color OneScanner at a glance

Now that you've unpacked the scanner and accessory kit and found a good location, take a moment to identify the most important parts of your new Apple Color OneScanner.

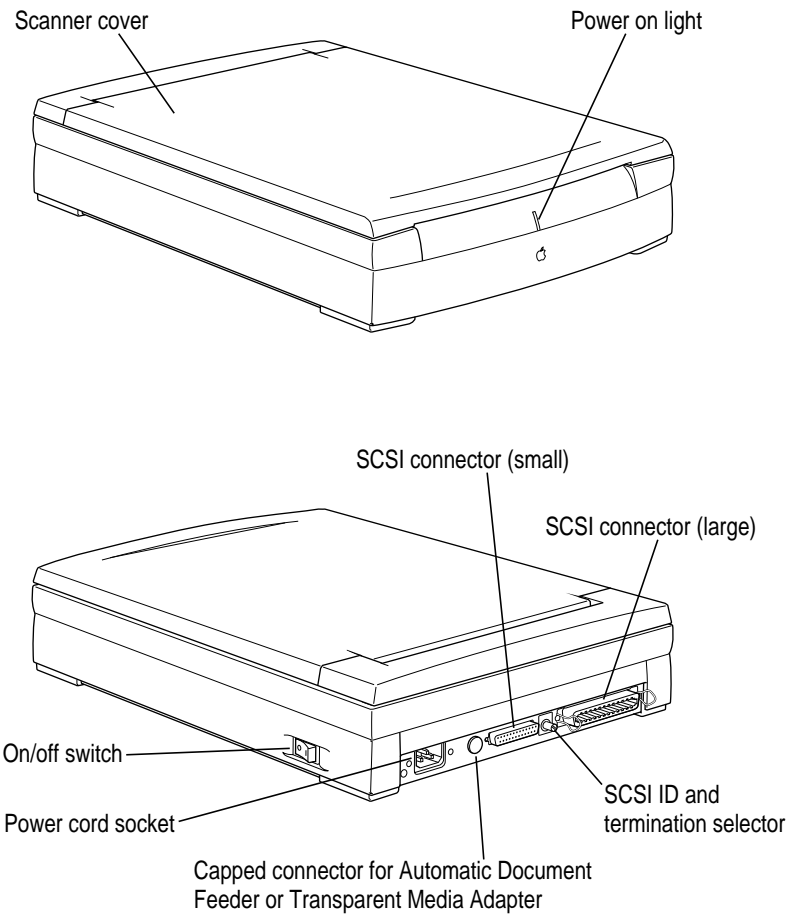

## Locking and unlocking the scanner

The Apple Color OneScanner carriage is locked during shipment. Make sure the carriage is unlocked. The scanner will not work if the carriage is locked.

If in the future you need to ship the scanner for service or move it to a different place, be sure to relock the scanning unit.

To lock or unlock the scanning unit:

- 1** Grip the scanner top cover on both sides and lift it off.

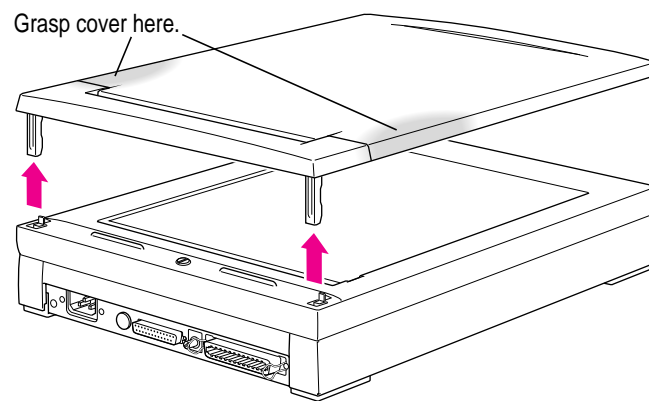

- 2** Use a coin to turn the lock to the locked or unlocked position.

Take care not to scratch the scanner glass.

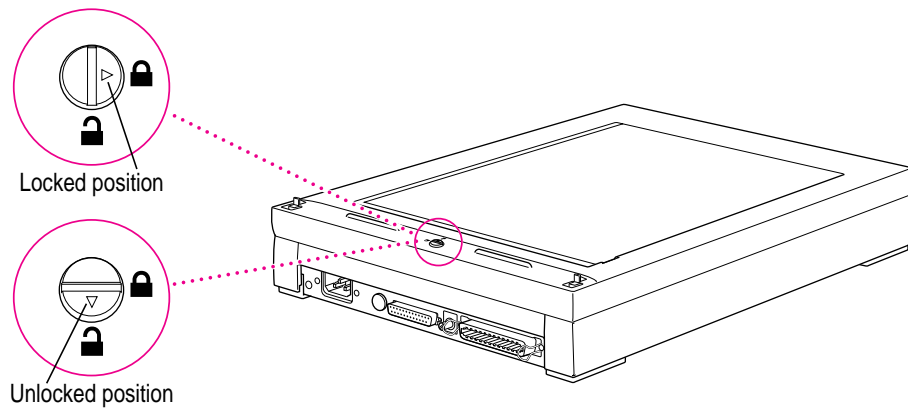

## Setting the SCSI ID number and termination

*You may not need this step. You can skip this topic if*

- the scanner is the only external SCSI device to be connected to your Macintosh
- or*
- you're setting the scanner up as the last device in a SCSI chain

If you need to change the SCSI ID number or termination setting, *do so after you review this topic and before you connect any cables.*

### About the SCSI ID number

A SCSI ID selector on the back of the scanner identifies the Macintosh port through which scanner information travels. The SCSI ID number is preset to 2. This factory setting is valid if you have no other SCSI device occupying SCSI ID number 2.

To choose a SCSI ID with termination **on**, use the "I" side of the dial. To choose a SCSI ID with termination **off**, use the "O" side. The ID numbers are the same on both sides.

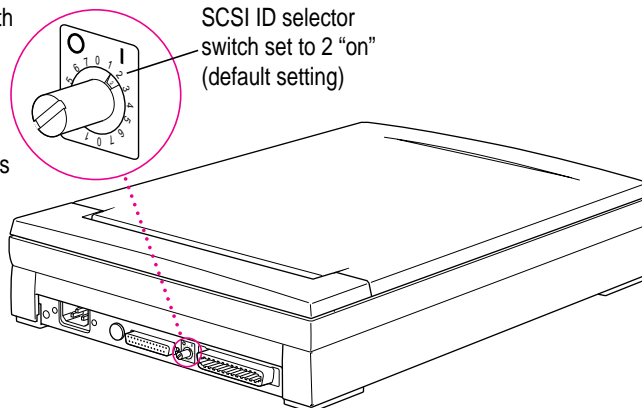

You can change the SCSI ID number if your configuration requires a different number.

*Numbers to avoid:* Don't assign numbers 0, 3, or 7 to the scanner. The default setting for the Macintosh computer is 7. The default setting for an internal CD-ROM player is 3. The default setting for the internal hard disk drive inside your Macintosh is 0. Make sure you use a number that is not assigned to any other SCSI device. Each ID number must be unique.

## About SCSI termination

The SCSI selector on the Apple Color OneScanner also works as a selector for internal SCSI termination. Termination is set to “on” at the factory.

If the scanner is the only SCSI device connected to your Macintosh or if you place the scanner as the last device in a SCSI chain, the “on” setting is correct and doesn’t need to be changed.

If the scanner is one device in a SCSI chain, but not the last device, you must turn off termination. See Appendix C for details.

## Connecting the scanner to your Macintosh

You’re now ready to connect the scanner to your Macintosh computer.

If you’re connecting the scanner to a Macintosh PowerBook, see the manual that came with your computer for instructions on connecting SCSI devices.

**WARNING** Before you begin, make sure that the power to the scanner, your computer, and any connected devices is switched off. If the power is on while you connect or disconnect SCSI cables, you can damage the system.

If you need to connect more than one SCSI device to your computer, follow the instructions above or those in Appendix C, “Assembling a SCSI Chain.” Correct placement of the devices and the cable terminator (if one is required) is important. You can damage your equipment if you connect the devices the wrong way.

## Connecting the SCSI cable

Follow these steps to connect the scanner directly to your computer.

- 1 **Plug the large end of the SCSI cable into the back of the scanner, and push the retaining clips into the tabs.**

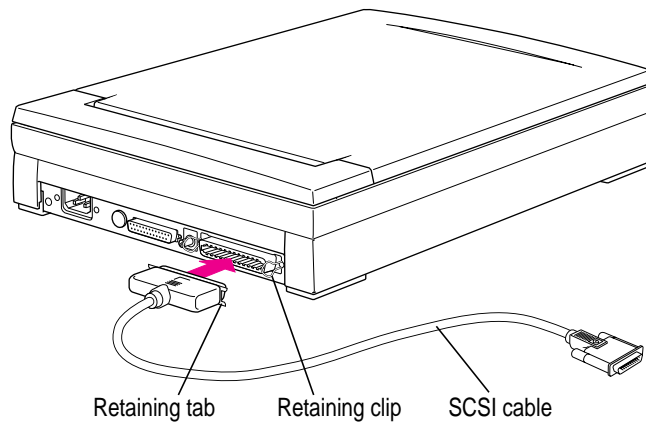

- 2 **Plug the small end of the SCSI connector into the back of the Macintosh, as shown.**

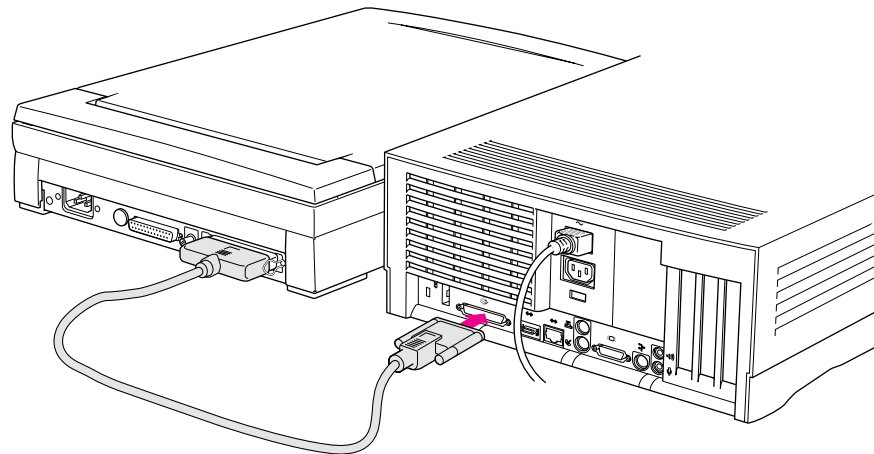

- 3 **Gently tighten the thumbscrews on the cable.**

You're now ready to attach the power cord.

## Connecting the power cord

Follow these steps to connect the power cord to the scanner:

- 1 **Align the holes in the socket end of the power cord with the pins of the power cord socket on the back of the scanner.**
- 2 **Plug the socket end of the power cord into the pins on the scanner.**
- 3 **Plug the other end of the power cord into a standard electrical outlet that accepts a three-pronged plug.**

**WARNING** This equipment is intended to be electrically grounded. Your Apple Color OneScanner is equipped with a three-wire grounding plug—a plug that has a third (grounding) pin. This plug will fit only a grounded AC outlet. This is a safety feature. If you are unable to insert the plug into the outlet, contact a licensed electrician to replace the outlet with a properly grounded outlet. Do not defeat the purpose of the grounding plug!

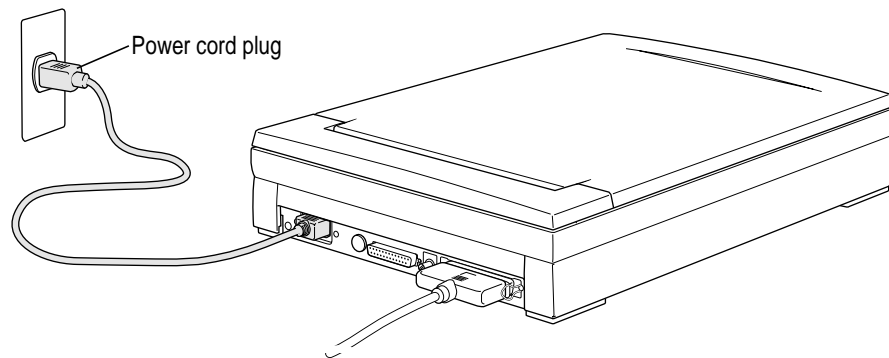

You're now ready to switch the scanner on and install the scanner software.

## Switching the power on

The scanner and other SCSI devices require that you switch the power on in a certain sequence.

To switch the scanner on:

- Press the on/off switch.

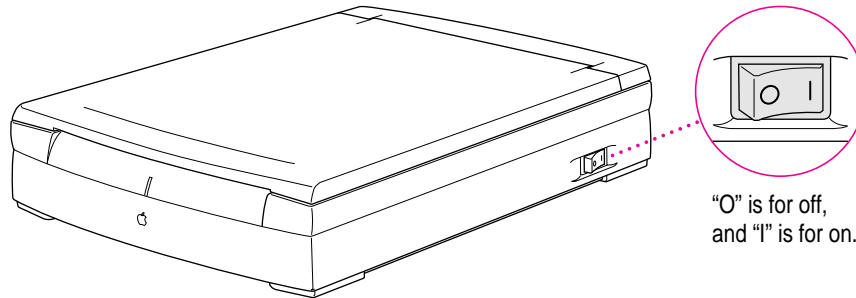

## Switching the power on

Equipment attached to computer	Switch on in this order
Scanner only	Scanner > computer
Scanner plus other devices	Scanner > other devices > computer

If you start the computer before you turn on the scanner, the computer won't be able to find the scanner.



## Important safety information

Any electrical device, when operated improperly, can be hazardous. Before you use your scanner, become familiar with these important safety precautions:

- Don't use the scanner near water.
- Use the power cord that is appropriate for use in the country in which you use the scanner.
- Never drop or insert objects of any kind into the scanner.
- Never spill liquid of any kind on or into the scanner. Should an object or liquid come into contact with high-voltage points inside the scanner, a fire could occur, or you could be exposed to electrical shock.
- If liquid of any kind is accidentally spilled on or into the scanner, immediately switch the power off and disconnect the power cord.
- Don't allow young children to handle power cords or cables.
- Be careful not to drop the scanner or allow it to collide with other objects.

## Where to go from here

You've now completed the hardware part of scanner setup. The next step is to install the scanner software. See Chapter 3, "Installing the Scanner Software," for instructions.



# 3

## Installing the Scanner Software



This chapter tells you how to install the software you need to use the Apple Color OneScanner. You'll find instructions for

- installing the Apple OneScanner Dispatcher application and related software
- installing the Apple Color OneScanner plug-in module for use with a compatible graphics application
- assigning the Xerox TextBridge application for use with the scanner software
- installing Kai's Power Tools and Convolver plug-ins from MetaTools (plug-in filters which come with the Color OneScanner 1200/30)

### About the disks

To install the scanner software, you need the disks that came with your scanner (in the accessory kit). You should have two disks: *OneScanner Dispatcher Disk 1* and *Disk 2*. These disks contain

- the Installer, a system program you use to install everything you need to use the scanner
- the scanner driver
- a Read Me file, which provides information available too late to be included in this manual, and the SimpleText application program for viewing the Read Me file

- ColorSync, a system program that records color information about scanned images so the colors stay consistent in different applications and on different devices, such as printers and monitors

Most of the files on these disks are compressed. To install them, you must use the Installer.

Your scanner package may include additional software. If you want to install and use the software, see the on-disk documentation that comes with the software for installation and user instructions.

**IMPORTANT** Apple recommends that you make backup copies of the disks and store the originals in a safe place. If you need instructions for copying disks, see your Macintosh user's manual.

## Installing the scanner software

To install the scanner software and start scanning, remember that you need at least 20 MB of space available on your hard disk. You must have system software version 7.5 or a later version to use the scanner with your Macintosh computer.

*Note:* If you're using a system with 8 MB of RAM, Apple recommends that you turn on Virtual Memory.

To install the software:

- 1 Turn off any automatic virus-detection programs and restart your Macintosh computer.

If you leave these programs on, problems may occur. You can turn the virus-detection programs back on after installation is complete.

- 2 Insert *OneScanner Dispatcher Disk 1* into a floppy disk drive.

If necessary, open the icon for *OneScanner Dispatcher Disk 1*. A window appears, showing the contents of the disk.

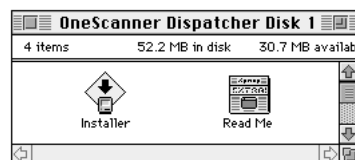

**3 Double-click the Installer icon.**

After a welcome screen appears (click Continue), an installation dialog box opens.

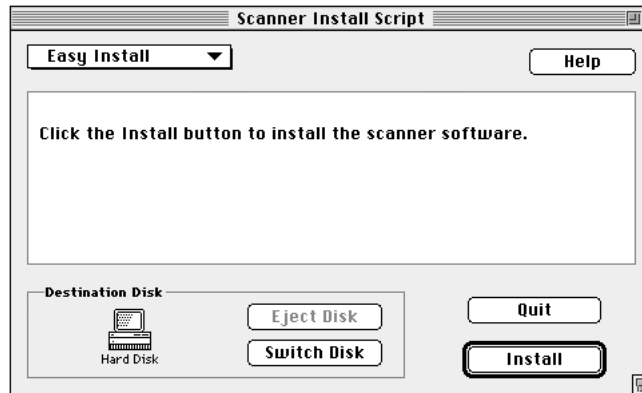

*Easy Install:* Apple recommends that you use the Easy Install process for your scanner software. Easy Install places all necessary files on your hard disk and updates any existing files as needed.

*Custom installations:* The Installer has a custom feature that allows you to choose specific items from a list and have them installed. To use this feature, click Easy Install in the Install dialog box to open a pop-up menu, and choose Custom Install. Then follow the instructions on the screen.

**4 Click Install and follow the instructions on the screen.**

A status box keeps you informed of progress during installation.

**5 When the process is complete, a message tells you that installation was successful.**

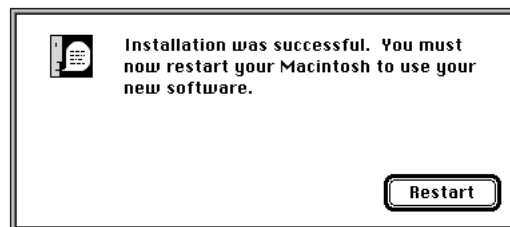

- 6 If the scanner is not on, switch it on.
- 7 Click Restart.

## Installing the plug-in module for use by other applications

The Apple Color OneScanner plug-in module allows you to scan images directly into applications compatible with Adobe Photoshop plug-ins. The user's manual for your application will tell you where the application requires you to place the plug-in module.

Before you install the plug-in modules, you must install the Apple Color OneScanner software, as described earlier in this chapter.

To install the plug-in module for use by another application:

- 1 Open the Apple Color OneScanner folder (the one you just installed on your hard disk).

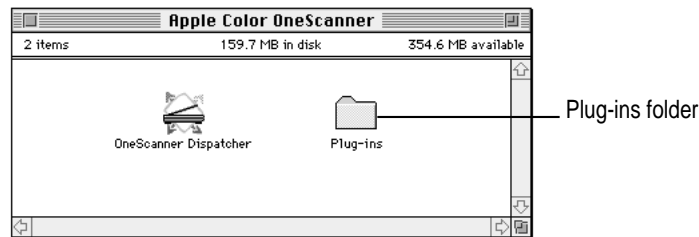

- 2 Open the Plug-ins folder, select the plug-in icon, and choose Duplicate or Make Alias from the File menu (Finder).

A copy or an alias of the plug-in module is created. (An alias takes up no space on your disk, a big advantage. For information about using aliases, see your Macintosh user's manual or Apple Guide, Apple's online help.)

- 3 Move the copy or the alias to the location you want.

The original plug-in must remain in the Plug-in folder in the Apple Color OneScanner folder or you will not be able to create new scans with the OneScanner Dispatcher application.

- 4 Drag the copy of the Apple Color OneScanner plug-in icon to the folder suggested by the user's manual for your graphics application.
- 5 When the plug-in icon is where you want it, delete the word "copy" and the space before the word.
- 6 If the user's manual for your application suggests a restart, restart your computer.

You can now scan images directly into the graphics application.

## Assigning the Xerox TextBridge 3.0H application to the Dispatcher

The TextBridge application, from Xerox Imaging Systems, Inc., analyzes an image of scanned text and converts each character into a form of text a computer can recognize. This process of text conversion is called *optical character recognition (OCR)*.

The TextBridge OCR application comes with the Apple Color OneScanner. You may have other OCR software that you prefer to use. The instructions that follow work for any compatible OCR application.

To assign the TextBridge application for use with the Apple Color OneScanner:

- 1 First, install the TextBridge application on your Macintosh computer.  
Follow the instructions in the TextBridge user's manual.
- 2 Open the Apple Color OneScanner folder and double-click the OneScanner Dispatcher icon.



OneScanner Dispatcher

The Dispatcher window opens on the Macintosh desktop.

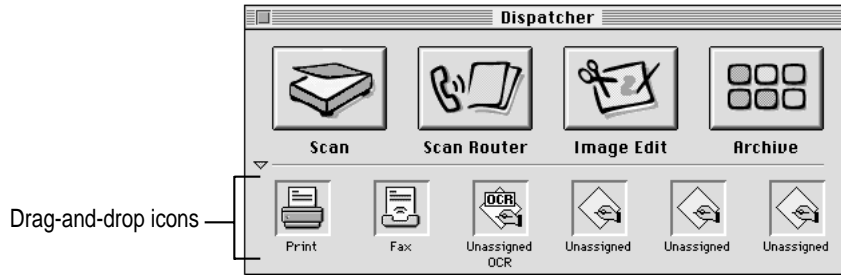

You'll find complete information about using the Dispatcher window in Chapter 4, "Scanning Images." For now, continue following these steps to assign TextBridge to the Dispatcher.

- 3** In the Dispatcher window, double-click the icon labeled Unassigned OCR.

A dialog box opens.

- 4** Move through folders (and disks, if necessary) to find the TextBridge application.

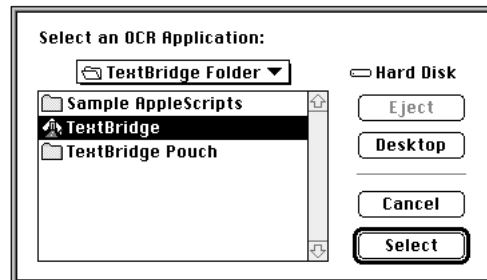



- 5 Double-click the TextBridge application name, or select the name and click Select.

The dialog box closes. TextBridge appears as the OCR icon.

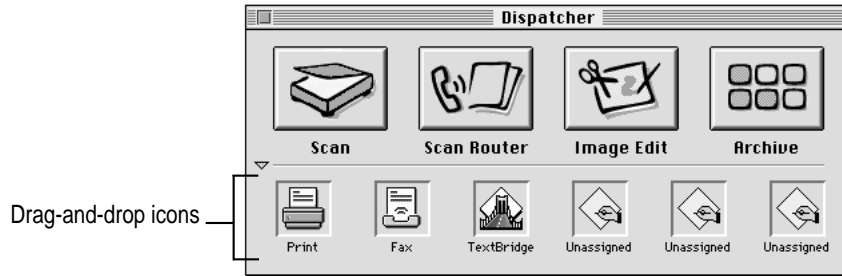

Like the other icons in this area of the Dispatcher window, the OCR icon is a drag-and-drop icon. To move text images into your OCR application, drag them to the OCR icon. For more information, see Chapter 6, “Scanning Text.”

## Setting up ColorSync

ColorSync is a system extension that helps maintain color consistency among different devices, such as scanners, monitors, and printers.

ColorSync is not turned on when you install the scanner software. If you want to use ColorSync as you work, you must turn it on and set preferences. For information, see “Setting ColorSync Preferences” in Chapter 5.

## Installing Kai's Power Tools and Convolver

Kai's Power Tools and Convolver are plug-in modules that provide filters compatible with Adobe PhotoShop and similar applications. To install these applications, follow the instructions in the user's manuals that came with them.

During installation, a dialog box appears that lets you select the Plug-Ins folder (inside the Apple Color OneScanner folder) as the correct destination for the new plug-in modules.

If you also need to place these plug-in modules in a special folder for an application you are using, make copies or aliases of the modules. Then drag the copies or aliases to the application's folder. (For details, see the user's manual for that application.) It is important to leave the original plug-in modules in the Plug-Ins folder inside the Apple Color OneScanner folder.

## Where to go from here

You've now completed the installation of the scanner hardware and software.

### **Will you be using the scanner only for images?**

- For a quick overview of the scanner software, see the *Quick Start* card for the OneScanner Dispatcher application.
- For details on scanning and customizing scanner settings, see Chapter 4, "Scanning Images."

### **Will you be using the scanner for optical character recognition (OCR) text scanning?**

- For a quick introduction to text scanning, see Chapter 6, "Scanning Text."
- For complete instructions for using the TextBridge application or another compatible OCR application, see the documentation that came with your software.

# 4

## Scanning Images



This chapter provides complete instructions for using the OneScanner Dispatcher application program with the Apple Color OneScanner. The chapter shows how to

- choose originals and align them on the scanner
- use the OneScanner Dispatcher application to scan, print, fax, save, and retrieve saved images
- use the drag-and-drop feature to print or fax saved images
- add drag-and-drop icons for compatible graphics applications
- scan an image directly into a compatible graphics application with the Apple Color OneScanner plug-in module

## What you can scan

You can scan almost anything you can put on the scanner glass:

- photographs and flat art
- drawings and calligraphy
- line art
- bound documents such as magazines and books

You should be aware of a few limitations:

- You cannot completely scan an item that is larger than 8.5 by 11.7 inches. The optional Automatic Document Feeder extends the scanning area to 8.5 by 14 inches.
- You cannot scan items that weigh more than 4.4 lb. (2 kg). Heavier items may damage the scanner glass.
- It is illegal to scan certain official and copyrighted documents. Please see “Copyright Regulations (USA)” at the end of this chapter for a summary of restrictions in the United States.

*Text and optical character recognition:* You can scan printed text and convert the image to text that can be read by a computer. To do this, you need special optical character recognition (OCR) software. Xerox TextBridge 3.0H OCR software comes with the Apple Color OneScanner. For an introduction to TextBridge, see Chapter 6, “Scanning Text,” in this manual. For information about using TextBridge, see the TextBridge user’s manual.

## Preparing originals

Follow these guidelines to prepare originals for scanning.

- Flatten out curled or wrinkled originals before you place them on the scanner glass.
- When you scan large, bound documents, you may find it helpful to remove the scanner top cover. For information, see “Removing and Replacing the Scanner Cover,” later in this chapter.

## Aligning a single original

To ensure that the alignment of the scanned image matches the alignment of the original, you can use the alignment mark.

To align an original page on the document glass:

- 1 **Lift the scanner cover, as shown.**

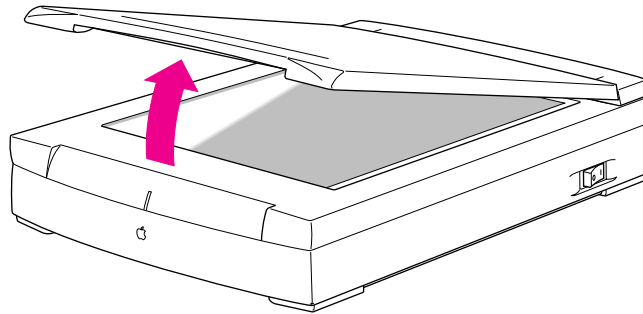

- 2 **Place the original *face down* on the document glass.**

Position the original so the top edge is toward the rear of the document glass and the top-right corner points to the alignment mark, as shown.

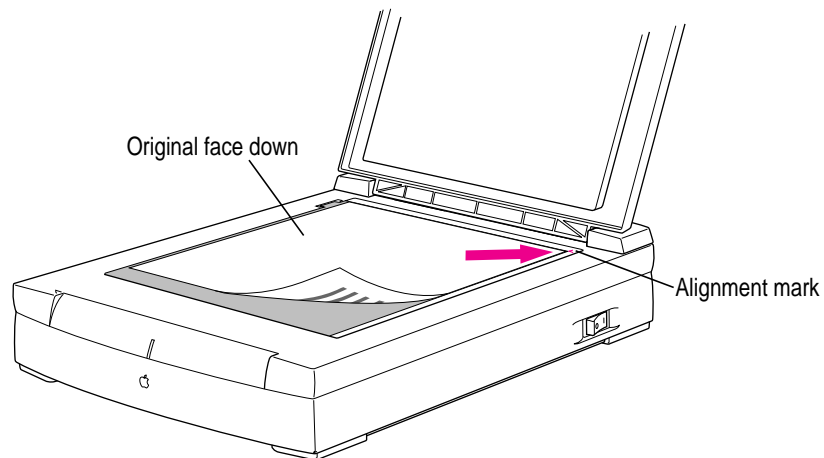

- 3 **See "Opening the OneScanner Dispatcher Application," later in this chapter, for complete scanning instructions.**

## Aligning bound originals

You can scan pictures or text in bound books with the Apple Color OneScanner. To simplify the placement of large bound originals, you may wish to remove the scanner cover. For instructions, see the next topic, “Removing and Replacing the Scanner Cover.”

To align bound originals:

- 1 **Open the bound document and place the page you want to scan face down on the document glass.**
- 2 **Position the page to cover as much of the glass as possible.**

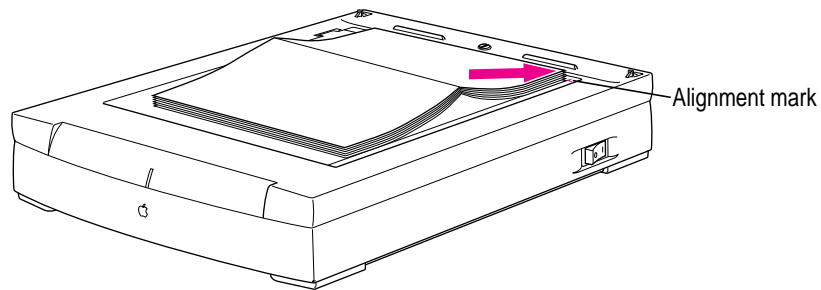

- 3 **See “Opening the OneScanner Dispatcher Application,” later in this chapter, for complete scanning instructions.**

## Removing and replacing the scanner cover

When you work with a bound document, you may wish to remove the scanner cover. Removing the cover makes it much easier to align the pages of bound items and makes the alignment more accurate.

To remove the scanner cover:

- 1** Position the scanner so the front is facing you.
- 2** Grip the cover as shown and lift it straight up off the scanner.

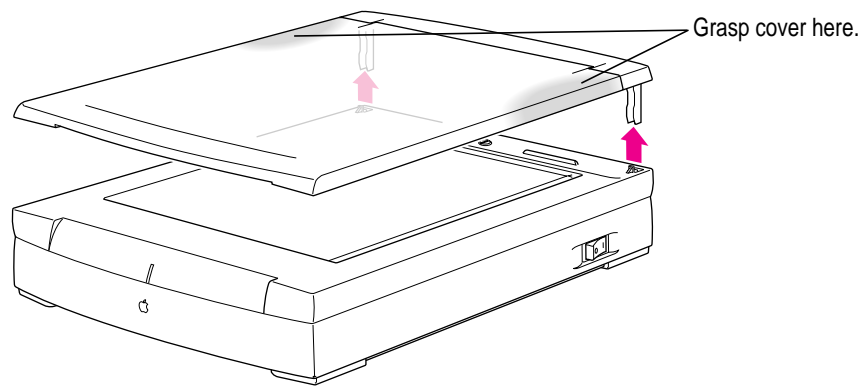

To replace the scanner cover:

- 1** Insert the metal posts into the scanner.
- 2** Gently push the cover down.

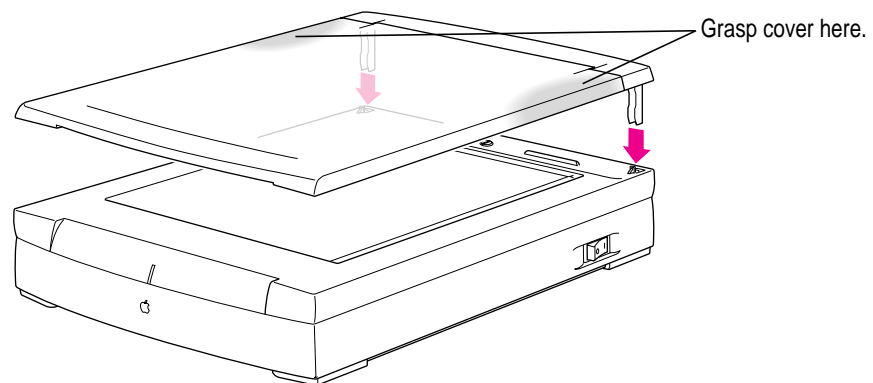

## Opening the OneScanner Dispatcher application

To start scanning, you need to open the OneScanner Dispatcher application.

- 1 Double-click the OneScanner Dispatcher icon.



The Dispatcher window opens.

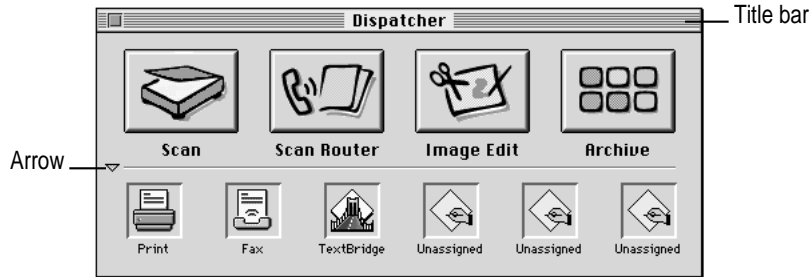

- 2 To hide (or show) the bottom half of the window, click the arrow.

You'll find information about using the Dispatcher window throughout this chapter.

- 3 To move the Dispatcher window anywhere on the desktop, drag it by its title bar.

You can leave the window in a convenient spot for handy access when you're ready to scan or edit images.



## How the OneScanner Dispatcher application is organized

The Dispatcher window is the control center for your scanning activities.

### Buttons

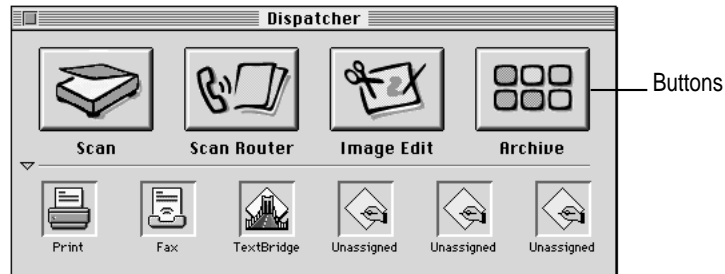

You use the buttons on the top half of the Dispatcher window to scan new images, send new images to your printer or a fax application, open and edit images you've already scanned and saved, and view images in thumbnail form.

*Example:* If you have a letter on the scanner glass and want to fax the letter, you use the Scan Router button to send the scanned image of the letter to your fax application.

## Drag-and-drop icons

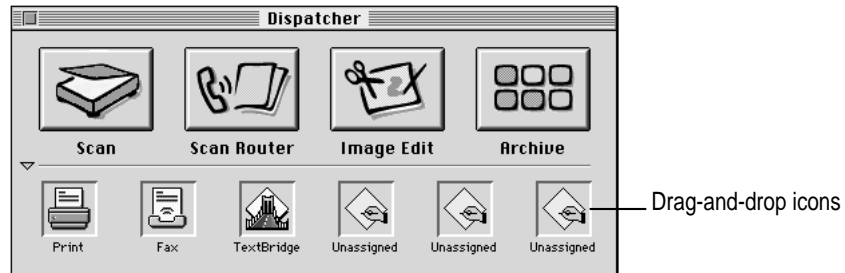

You use the icons on the bottom half of the Dispatcher window to drag and drop saved images you want to send to a printer, a fax application, an optical character recognition (OCR) application, or an application you add, such as a graphics application.

*Example:* You may have an archive full of images you've scanned. If you want to fax one of the images, you simply drag the image's thumbnail from an image archive and drop the thumbnail onto the Fax icon. Your fax application opens, allowing you to address and transmit the fax without going through a separate operation.

## Scanning with automatic settings

The OneScanner Dispatcher application comes preset to scan most color and black-and-white originals. For your first scanned images, you may wish to work with the automatic settings. Later, when you're ready for fine-tuning, you can customize the settings.

To scan a document and create a new image:

- 1 Put the original document on the scanner glass and close the scanner cover.**

For more information, see “Preparing Originals,” earlier in this chapter.

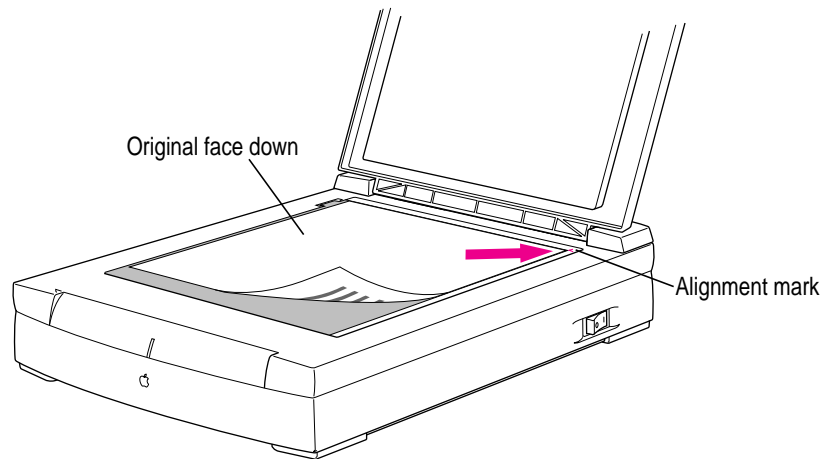

- 2 If necessary, open the OneScanner Dispatcher application by double-clicking its icon.**

The Dispatcher window opens:

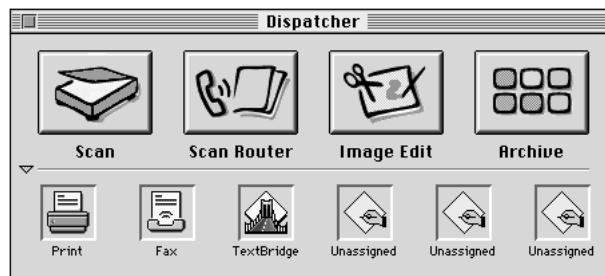

**3 Click Scan.**

The Apple Color OneScanner dialog box opens.

**IMPORTANT** If you have a PowerBook and cannot see the controls at the bottom of the dialog box, you must change the setting in your Monitors control panel. Open the control panel, click Options, and choose 640 x 400.

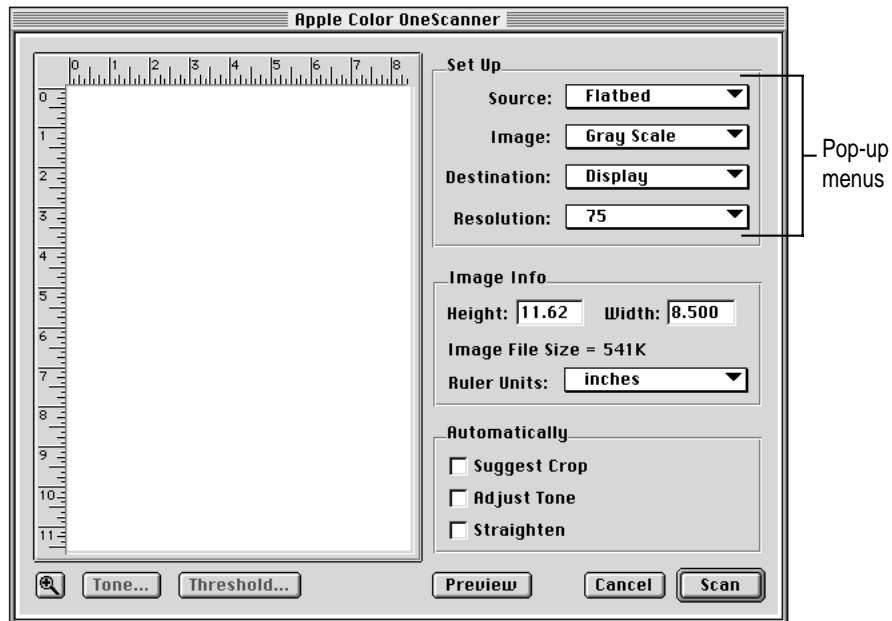

**4 To make sure the correct options are selected, check the Set Up pop-up menus.**

**Source** If you've attached an Automatic Document Feeder or Transparent Media Adapter, you need to specify it as the source of the scan. Choose Feeder or Transparency from the Source pop-up menu.

**Image** Choose the type of image you're scanning from the Image pop-up menu. The options are Color, Grayscale, Black and White, and Halftone. Choosing Halftone opens a dialog box where you can choose a pattern for the halftone screen. The patterns determine the shape and number of the dots when the screen is created. Try different patterns to find the one that looks best on your monitor or in a document you print.

**Destination** Choose a destination for the image. The destination you specify is used to determine the resolution at which the scanner will scan the image. For example, if you select **Monitor** as the destination, the **Resolution** pop-up menu automatically chooses the resolution that is correct for most monitors. You can, however, change the resolution setting if you wish. You can also specify a custom resolution.

**Resolution** Choose the resolution you want to use. The resolution is automatically set for the output device (destination) you've chosen, but you can choose a different resolution if you wish. For more information on resolution settings, see "Scanning With Custom Settings," later in this chapter.

**5 Click Preview.**

The scanner creates a preliminary image in the preview area of the dialog box.

*Tip:* When the preview shows as much of the image as you want, you can stop the scanner by pressing ⌘-. (Command-period).

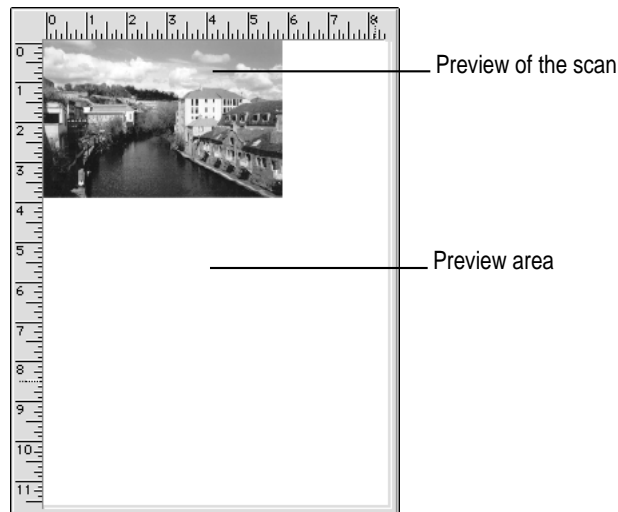

**6 Drag to select the area you want.**

A marquee (dashed line) surrounds the selected area. The Image Info area changes to reflect the size of the selection. Image height, width, and size change depending on the selection you make.

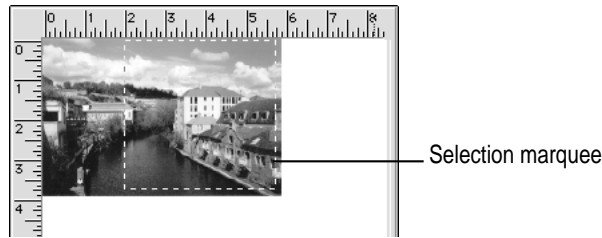

**7 If you want to zoom in, click the zoom button (optional).**

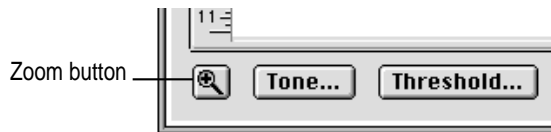

The area in the zoom view is the area that will be scanned. To return to the original view, you must click Preview and start over.

**8 Choose any automatic adjustments you may want the scanner to make.**

*Note:* These adjustments take extra time and won't work with all images.

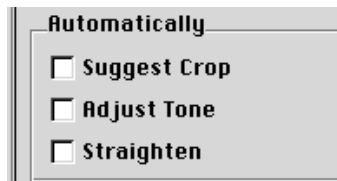

**Suggest Crop** The scanner analyzes the picture for dominant shapes and crops the image appropriately when the scan occurs.

**Adjust Tone** The scanner checks image brightness and contrast and adjusts for them.

**Straighten** The scanner looks for the top and side edges of the image and adjusts the orientation of the image when the scan occurs.

**9 Click Scan.**

The scanner scans the original.

When the scan is complete, the image appears in a new document. The document is named Image1. Subsequent scans in the same session are named Image2, Image3, and so on.

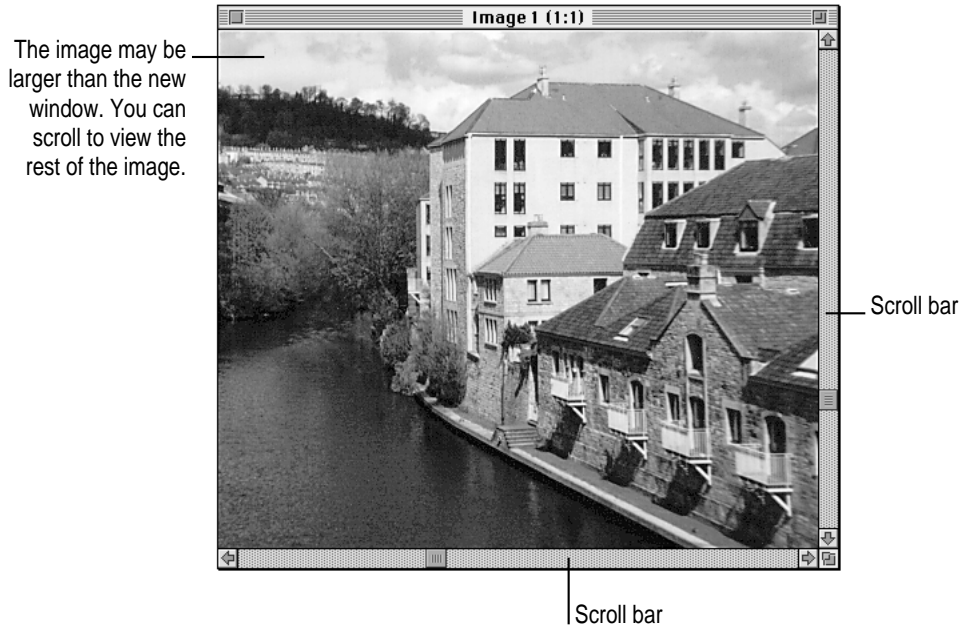

Each dot on the scanned image corresponds to a pixel on the computer screen. The higher the resolution (the greater the number of dots per inch), the larger the image appears on the screen. So an image scanned at 75 dpi appears smaller than one scanned at 300 dpi. To change the size of the image, choose *Zoom In* or *Zoom Out* from the *Image* menu.

## Saving a scanned image

As soon as the scanner has completed a scan, the new image, with the name Image1, appears in a window on the Macintosh desktop, as shown at the end of the previous topic. You can save the image with a more useful name, and in a different folder, if you wish.

To save and rename a new image:

- 1 **Make sure the image window is active.**

To activate the document, click anywhere in the image window.

- 2 **Choose Save from the File menu.**

The Save dialog box opens.

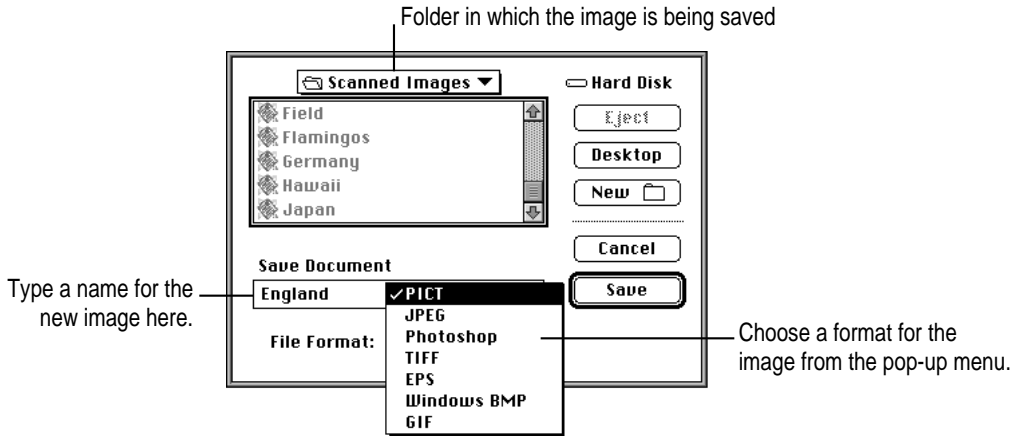

- 3 **Type a name in the Save Document box.**

- 4 **Choose a folder or disk drive for the file.**

For more information on switching folders, see your Macintosh manual.



**5 Choose an image format from the File Format pop-up menu.**

**PICT** (default setting): A widely used format that is compatible with most Macintosh applications (uses ColorSync).

**JPEG** Joint Photographic Experts Group, a format that compresses files and lets you choose compression versus quality.

**Photoshop** A format that supports all available Adobe Photoshop image modes.

**TIFF** Tagged-Image File Format, a format used to exchange documents between different computer systems (for example, between Macintosh and Windows computers). This format is recommended when you scan text.

**EPS** Encapsulated PostScript™, a format supported by most illustration and page-layout applications.

**Windows BMP** A format commonly used on MS-DOS and MS-Windows computers.

**GIF** A format used on the Internet, GIF supports only 256 colors or grays.

**6 Click Save.**

The Macintosh stores the image in the folder you chose.

When you next view the folder as an archive, this image and others in the folder will appear as thumbnails—small representations of full-size images. The thumbnails make it easy for you to identify the images you've scanned.

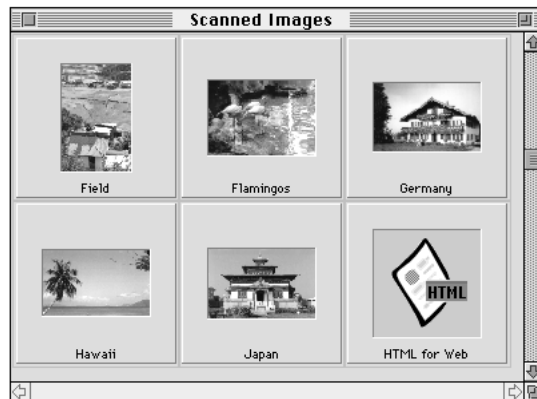

An image archive.  
Scanned images  
appear as thumbnails.

## Assigning a fax application to the Dispatcher

Before you can use the scanner for faxing, you must assign the driver for your fax application to the Dispatcher. (If you have a fax modem or fax machine connected to your computer, use the driver that came with it.)

- 1 In the Dispatcher window, click the Fax drag-and-drop icon.
- 2 In the dialog box that appears, find the driver for your fax application.

The Dispatcher takes you to the Extensions folder where your fax driver should be.

## Faxing or printing directly from the scanner

You can place a document on the scanner glass and send its image directly to your fax application where you can then address and transmit the new image. (If you have a fax modem or fax machine connected to your computer, use the application that came with it.) Or, you can send the image to your printer.

*Example:* Sign or mark up an incoming fax that you've printed, scan the marked-up original, and transmit the revised image to your fax application.

- 1 Put the original document on the scanner glass and close the scanner cover.
- 2 If necessary, start the OneScanner Dispatcher application by double-clicking its icon.

The Dispatcher window opens.

- 3 Click Scan Router.
- 4 In the Scan Router dialog box that appears, click an Image option to specify the type of image.

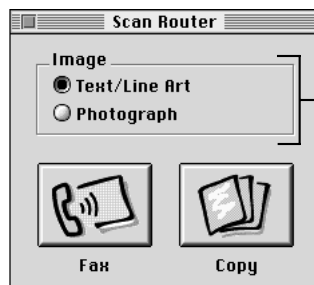

For text and simple line drawings, choose Text/Line Art.  
For photographs, full-color art, or grayscale art, choose Photograph.

**5 Click Fax or Copy.**

*Printing (Copy):* The Print dialog box opens. Specify the number of copies you want, set any other options, and click Print.

The original is scanned and sent to your fax application or currently chosen printer.

*No image document created:* When you fax or print an image using the Scan Router, an image document (file) is not created. The scanner simply sends the new image to the fax application or printer. To fax or print the image again, you must rescan it.

## Opening a saved image from an archive

Images you scan into the Macintosh using the Color OneScanner and Dispatcher are stored in folders called *archives*. Archives contain images and Hypertext Markup Language (HTML) files shown as thumbnails—little sketches that represent full-size images.

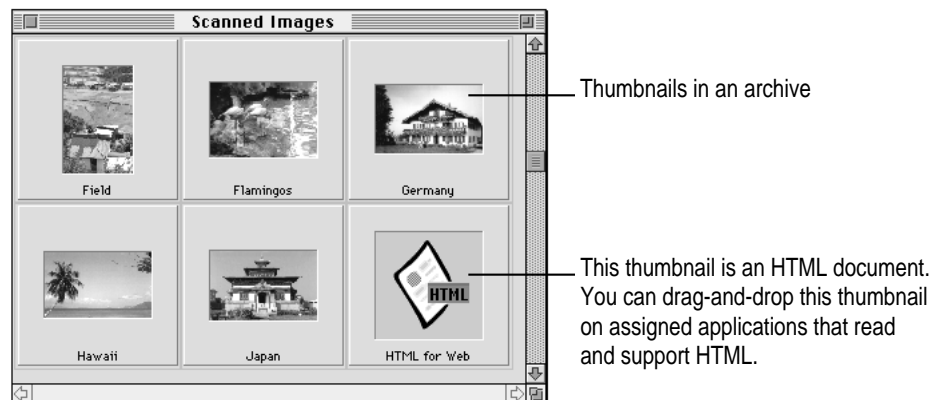

To open a saved image:

- 1 If necessary, start the OneScanner Dispatcher application to open the Dispatcher window.
  - 2 Click Archive.
- A dialog box opens.
- 3 Select the name of the folder you want.

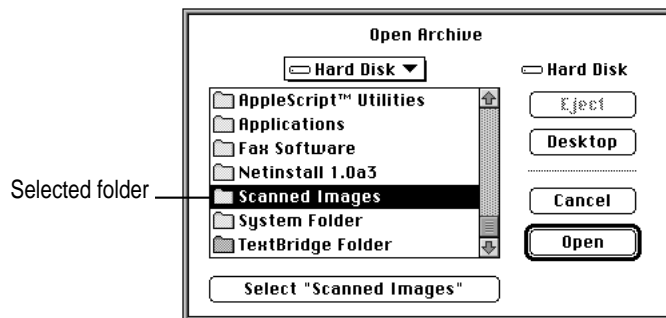

- 4 Click Select “folder name” (the large button at the bottom of the window).

An archive opens, showing thumbnail representations of your images.



- 5 To open an image, double-click it.

You can use the image-editing tools and commands to modify the image or select and copy parts of it. For information, see Chapter 5, “Editing Scanned Images.”

*Note:* To open an HTML thumbnail from the archive, you must drag the thumbnail to the drag-and-drop icon of an application that reads and supports HTML files. Double-clicking the HTML thumbnail will not open it.

## Renaming a saved image in an archive

To rename an image that is open:

- 1 **Choose Save As from the File menu.**
- 2 **In the dialog box that appears, give the image a new name.**

To rename an image in the Finder desktop

- 1 **Click the icon to select the image and its name.**
- 2 **Type a new name.**

## Printing or faxing a saved image from an archive

You can use the drag-and-drop icons to send a saved image directly to your printer or fax application.

To print or fax a stored image:

- 1 **If necessary, open the Dispatcher window.**
- 2 **Click Archive and open the archive that contains the image you want to fax.**

For instructions on opening archives, see “Opening a Saved Image From an Archive,” earlier in this chapter.

**3 Drag the thumbnail from the archive onto the Print or Fax icon.**

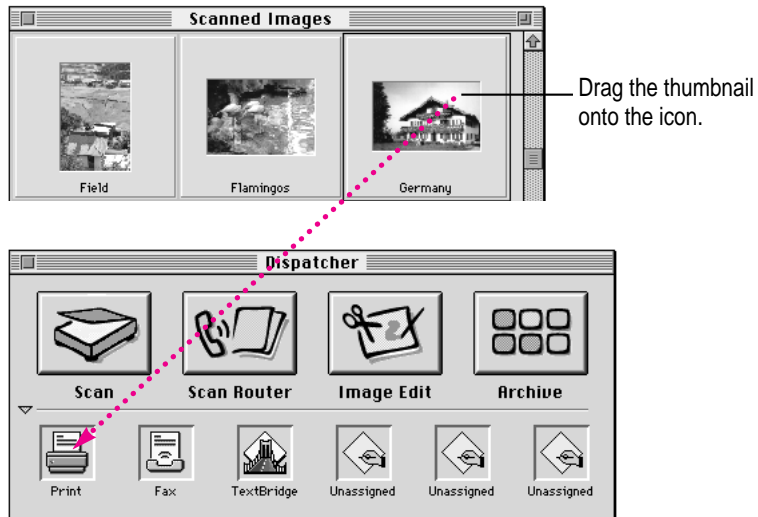

**Faxing** If this is your first fax, a dialog box asks you to find your fax driver. (For instructions, see “Assigning a Fax Application to the Dispatcher,” earlier in this chapter.) If this is not your first fax, your fax application opens, ready for you to address and transmit the scanned image.

**Printing** The Print dialog box opens. Set the options you want to use, and click Print. (Make sure you have selected a printer in the Chooser before you try to print.)

The image is sent to the printer or fax application.

## Adding your own drag-and-drop applications

To speed up your work, you can add an application you frequently use to the unassigned drag-and-drop icons. You can then send an image to the application by dragging a saved image onto the icon and dropping it there.

*Example:* You may routinely rework scanned images in the MacDraw® Pro application. Ordinarily, you must scan an image, copy it, and paste it into a MacDraw Pro document. With a MacDraw Pro drag-and-drop icon, you can simply scan and save a series of images and then drag the thumbnails, one by one, onto the icon. MacDraw Pro automatically opens the image in a new document.

To add your own drag-and-drop application:

- 1 If necessary, open the Dispatcher window.

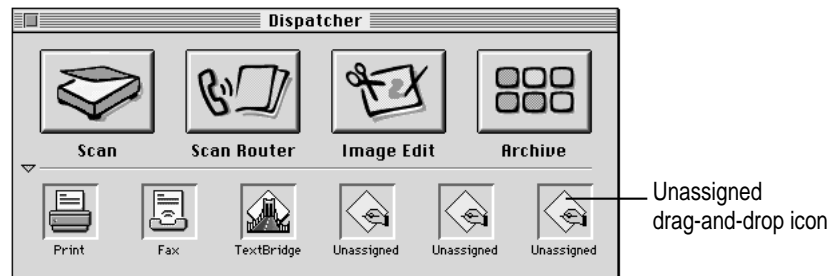

- 2 Click one of the icons labeled Unassigned.

A dialog box opens.

- 3 Move through folders (and hard disks, if necessary) to find the application you want to add.

The application you select must support drag-and-drop behavior and must be able to open documents in formats supported by the Dispatcher (such as PICT and TIFF).

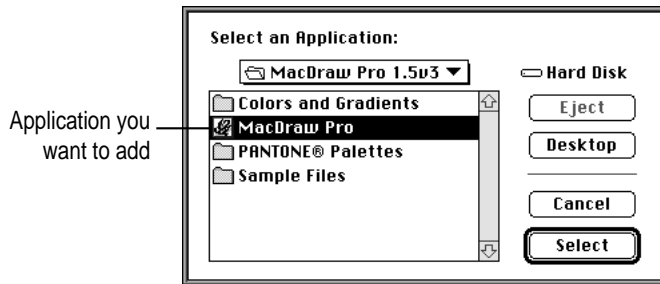

- 4 Double-click the application name, or select the name and click Select.

The dialog box closes. The application's icon appears in the previously unassigned icon.

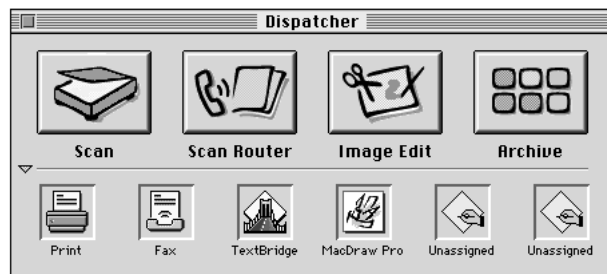

You can now use the icon to drag and drop scanned images.



## Scanning directly into a graphics application

The OneScanner Dispatcher application comes with the Apple Color OneScanner plug-in module. A *plug-in* is a software module that extends an application for a specific purpose, such as importing scanned images.

**IMPORTANT** If you haven't already installed the Apple Color OneScanner plug-in module, see "Installing the Plug-In Module for Use by Other Applications" in Chapter 3.

With the plug-in module and a compatible graphics application, you can scan directly into a document without creating and saving an image with the OneScanner Dispatcher application.

*Example:* You can use the Adobe Photoshop Acquire command to scan an image directly into an Adobe Photoshop document.

For information about installing and using the scanner plug-in module with your graphics applications, see Chapter 3, "Installing the Scanner Software," and the manual for your graphics application.

*Note:* The following steps are intended as a general example. Your application may work differently.

- 1 **Open the application you want to use.**
- 2 **Choose the application's Acquire command.**

**3 Choose Apple Color OneScanner (the plug-in module) as the source of the acquisition.**

The Apple Color OneScanner dialog box opens.

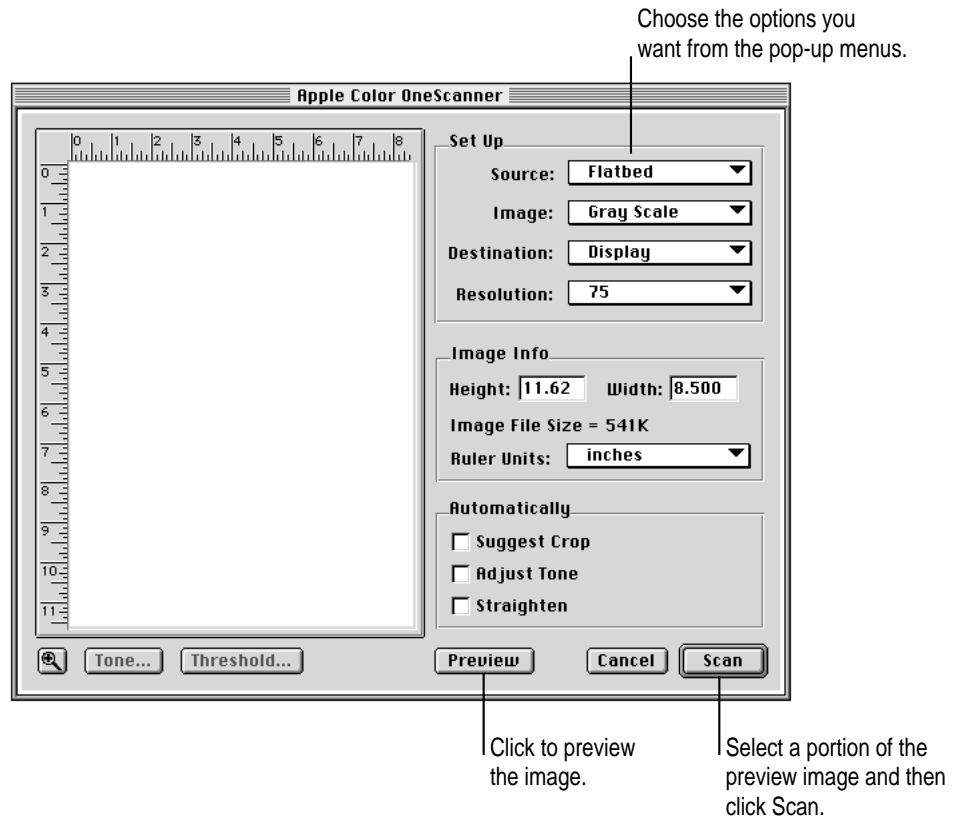

**4 Click Preview, and change scanner options if necessary.**

For information, see “Scanning with Automatic Settings,” earlier in this chapter.

**5 Click Scan.**

The image is scanned and inserted in a new document for the application.

## Scanning with custom settings

After you've scanned a number of images, you may want to customize the settings in the Apple Color OneScanner dialog box. This section provides detailed information about settings for resolution, tone, and threshold.

### Setting the resolution

The level of detail in a scanned image is determined by the number of dots per inch (dpi) the scanner uses to reproduce an image. The number of dots per inch defines the *resolution*.

Higher resolutions provide more detail. Accordingly, the quality of a scanned image increases with higher resolution—but not always.

### Things to think about when you set the resolution

Consider these factors when you choose a resolution:

- Each dot on the scanned image corresponds to a pixel on the computer screen. The higher the resolution (the greater the number of dots per inch), the larger the image appears on the screen.
- As resolution increases, you need more memory and disk space to scan and store the image on your hard disk drive. Sometimes the extra resolution may not be worth the extra memory or disk space.
- When you choose a resolution, check the Image Info area for image size before you scan.
- Scanning at a higher resolution may not necessarily produce better results because the printer or other output device (such as a monitor) may not reproduce the higher resolution. For example, a monitor may display an image at 72 dpi, even though the image is at 600 dpi. In general, choose the lowest dpi setting that will meet your needs.
- Large images take longer to print, and the quality of the printed version is still limited by the capabilities of the printer.
- Large images take longer to scan, save, view, and manipulate.

### Recommended resolutions for maximum efficiency

The chart below shows the settings that Apple recommends for the output devices listed. Keep in mind that an image scanned at a higher resolution will require more memory and take longer to scan and print.

#### Recommended scanning resolutions

For this output device	Set the scanning resolution at
Computer screen	75 dpi
Laser printer, 300 dpi	100 dpi
Color laser printer, 600 dpi	150 dpi
Laser printer, 600 dpi	150 dpi
Linotronic imagesetter	200 to 300 dpi
Fax output device	75 dpi
Inkjet printer	100 dpi



## Changing the tone (brightness and contrast)

You can improve the appearance of a scanned image by adjusting the tone before you scan the image. *Tone* is a measure of brightness and contrast—the intensity of blacks and whites, or colors, in a scanned image.

The way your monitor is set up affects the way an image appears on the screen. For information, see your monitor manual.

### Brightness

Brightness determines the overall lightness of a scanned image.

- With increased brightness, the scanned image generated by the scanner will be lighter.
- With decreased brightness, the scanned image will be darker.

### Contrast

Contrast is a measure of differences between light and dark tones.

- With increased contrast, all light tones become increasingly lighter, and all dark tones become increasingly darker at the same rate.
- With decreased contrast, all light tones become increasingly darker, and all dark tones become increasingly lighter at the same rate.

To change the tone of a scanned image:

- 1 In the Dispatcher window, click **Scan** to open the Apple Color OneScanner dialog box.
- 2 Click **Preview**.
- 3 Drag to select the portion of the image you want to scan.

**4 Click Tone.**

The Tone dialog box appears.

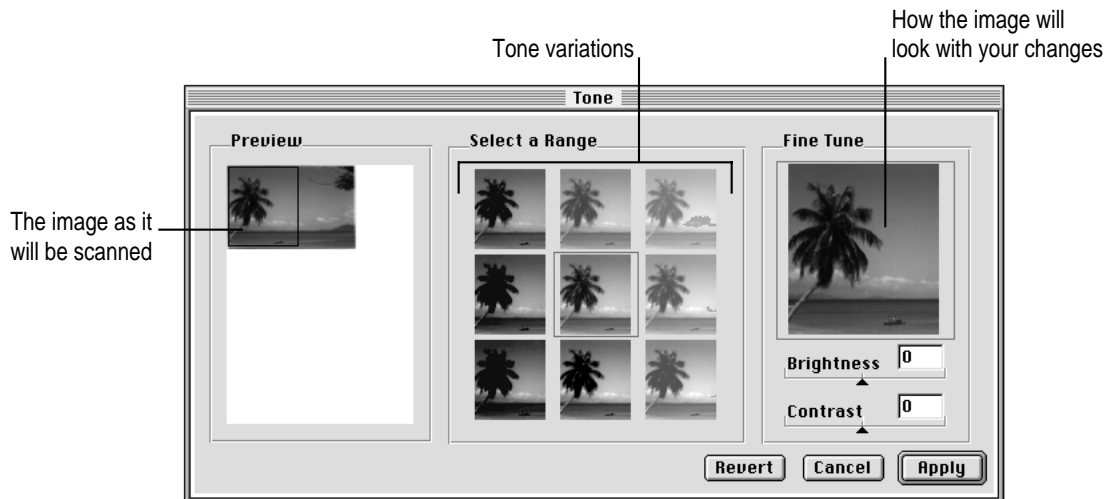

**5 Drag to select the portion of the preview you want to use as a sample for brightness and contrast.**

A solid outline appears around the selection. You can drag the outline to a different part of the preview if you want to sample different areas. When you release the mouse button, the selected area becomes the central point for tone variations.

**6 Select a sample from the Select a Range options.**

**Brightness** From left to right, the tone variations show brightness from darker to lighter.

**Contrast** From top to bottom, the variations show contrast from less to more.

When you click one of the variations, the preview changes and the variations themselves are readjusted, using your recent selection as a new starting point. The Fine Tune view changes to reflect your choice in the center panel, outlined in red.

**7 To fine-tune the tone, drag the Brightness and Contrast sliders to change the settings.**

The Fine Tune view shows the effects of any changes you make.

- 8 To return to the Apple Color OneScanner dialog box, click Apply.

If you want to return the image to its original state, click Revert.

- 9 When the settings are the way you want them, click Scan.

The image is scanned using the settings you chose.

## Changing the threshold

You can customize scanned images by resetting the threshold. *Threshold* is a measure of the darkest dark colors and the brightest light colors. In a black-and-white image, threshold is the point at which a dark color becomes black and a light color becomes white.

To change the threshold:

- 1 In the Dispatcher window, click Scan to open the Apple Color OneScanner dialog box.
- 2 Click Preview.
- 3 Drag to select the portion of the image you want to scan.
- 4 Click Threshold.

The Threshold dialog box opens.

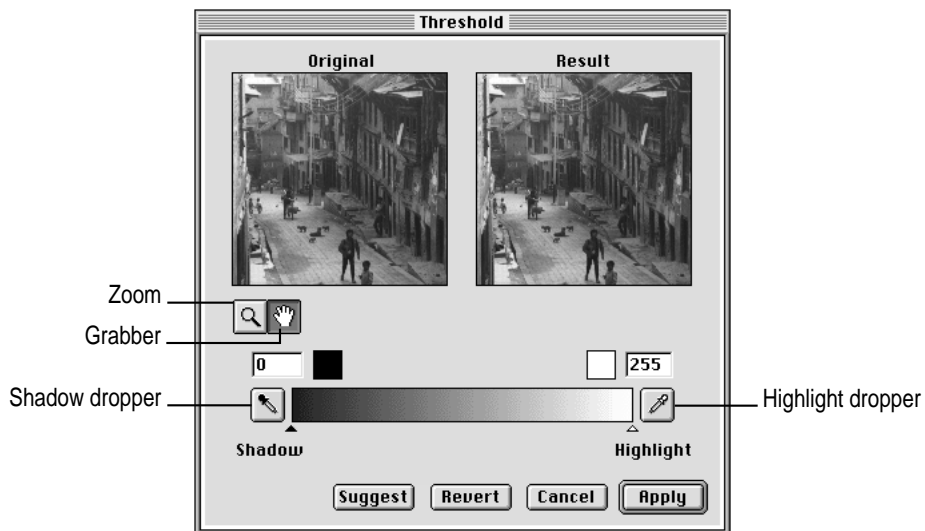

**5 In the Threshold dialog box, make the changes and selections you want.**

- If you want the Dispatcher to recommend the appropriate threshold settings, click Suggest.
- If you want to customize the threshold settings yourself, you can.

To set the lightest value, click the highlight dropper and then click the spot in the original that you want to use as highlight threshold. The slider adjusts to show the point you set, and the result adjusts to the change. The point you set becomes the lightest color in the image. Colors lighter than this point are reset to this level.

To set the darkest value, click the shadow dropper and then click the spot in the original that you want to use as shadow threshold. The slider adjusts to show the point you set, and the result adjusts to the change. The point you set becomes the darkest point in the image. Colors darker than this point are reset to this level.

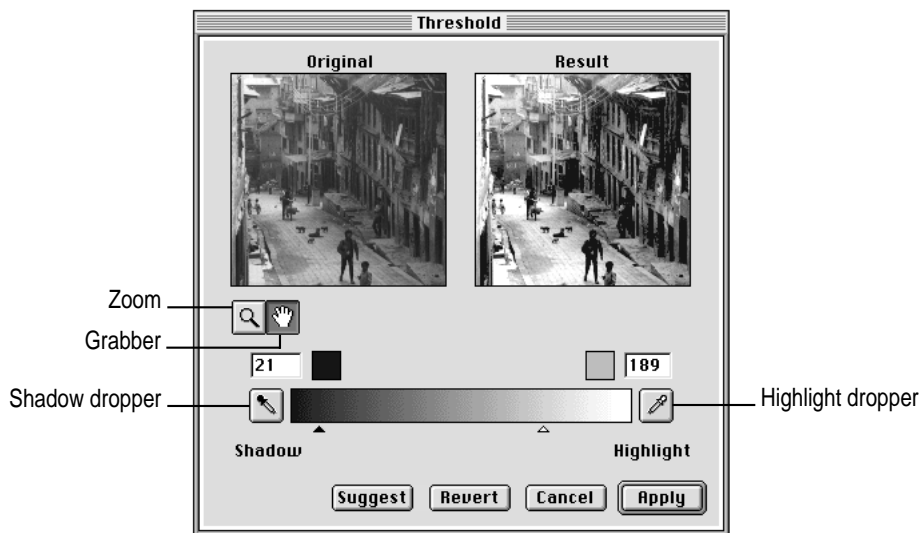

*Tip:* To work with a specific area of the image, click the zoom tool and then click the area you want. Use the grabber to move the original image around if necessary.



- 6 To return to the Apple Color OneScanner dialog box, click Apply.

To return to the original settings, click Revert.

- 7 Click Scan.

The image is scanned with the settings you chose.

## Changing image size and ruler units

The Apple Color OneScanner dialog box provides information about the size of a scanned image and the size of the document (file) the image will occupy.

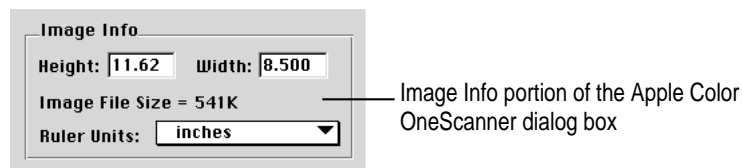

## Viewing and changing image size (dimensions)

The Height and Width boxes show the size of the preview image or of the selected area within the preview image.

Dimensions are determined by

- the size of the image area to be scanned
- the resolution setting

The minimum area you can scan is 48 by 32 pixels.

To specify the size of the scan:

- **Type a value in the Height and Width boxes.**

A marquee appears in the upper-left corner of the preview, scaled to the size you typed. To select a different part of the image, move the pointer inside the box formed by the marquee and drag the box where you want it.

## Viewing image file size

Image File Size shows how much memory, in kilobytes, the image file will occupy. File size is determined by

- the image type and resolution
- the size of the image area to be scanned

## Changing the ruler units

You can set the ruler to use a different unit of measure for the height and width of an image. You can set the ruler for inches, centimeters, pixels, points, and picas.

To change ruler units:

- **Choose the units you want from the Ruler Units pop-up menu.**

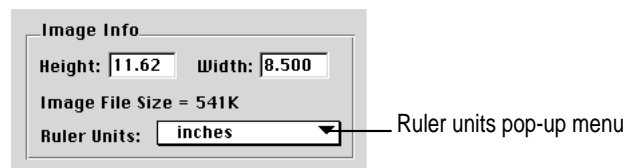

## Copyright regulations (USA)

It is illegal to reproduce certain official or copyrighted documents, and doing so may be punishable by criminal or civil law. The following documents may not be copied:

- currency
- government-issued securities and passports
- publicly or privately issued licenses or permits
- official documents
- private documents

In addition, it is unlawful to make copies of the following copyrighted works, except for personal or household use or for other uses permitted under the terms of the copyright:

- copyrighted publications
- music scores
- paintings
- prints
- maps
- drawings
- movies or photographs
- other copyrighted works



# 5

## Editing Scanned Images



You can use the OneScanner Dispatcher application to edit and improve the appearance of scanned images. You can add and adjust colors, change the size, crop an image, or copy selected areas to other documents.

This chapter tells you how to

- open a saved image and show the editing tools
- use the tools to edit your images
- change your view of a scanned image

## Opening a saved image

To open and edit a saved image, you first open the OneScanner Dispatcher window and then open the image you want to edit.

To open the Dispatcher window:

- 1 **Double-click the OneScanner Dispatcher icon.**

The Dispatcher window opens.

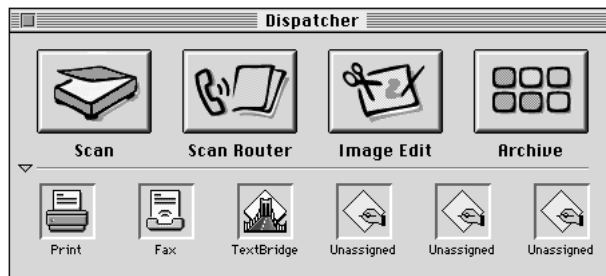

- 2 **Click Image Edit.**

A dialog box opens.

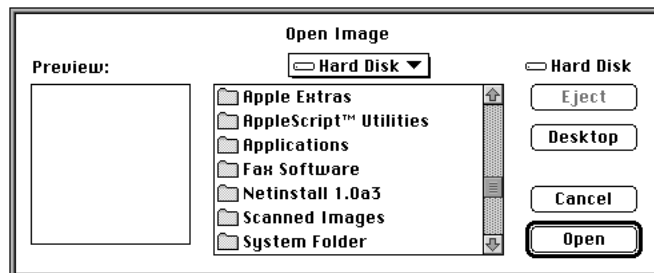

**3 Open the folder that contains your saved images.**

The first image is automatically selected. A preview appears on the left to help you identify the image. Selecting another image name changes the preview.

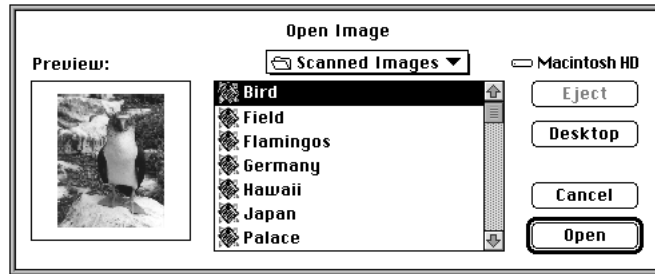

**4 To open the image document, double-click an image name.**

The document opens, and the tool, color, and brush palettes become available. If you don't see the tools, choose Show Tools, Show Brushes, or Show Colors from the Window menu.

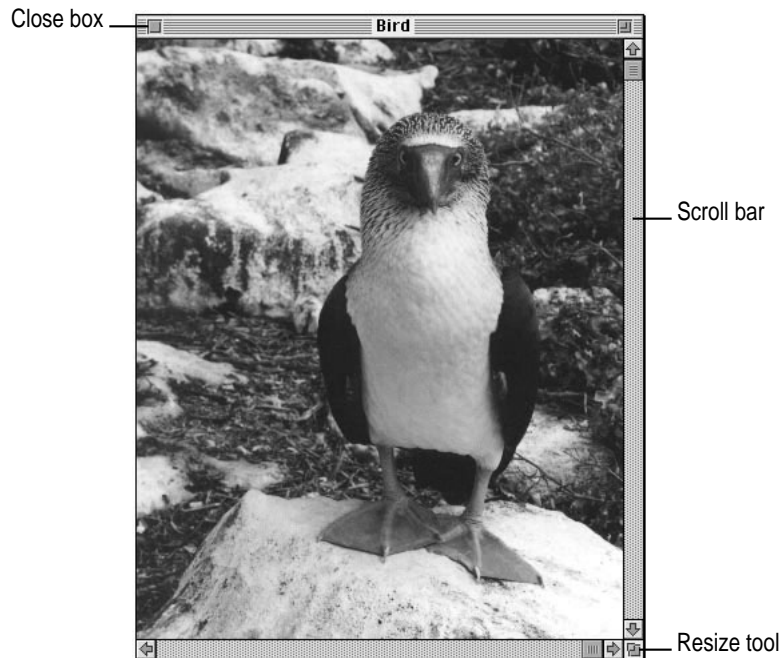

## Image-editing overview

When you save a scanned image, the application stores it as an image document. The image within the document is made up of pixels—the dots that form any image on the computer screen. When you use the tools, brushes, and color palette, you change the arrangement or appearance of the pixels.

### Tool palette

Use the tools in the tool palette to select portions of the image, add text or color, erase portions of the image, and do other tasks.

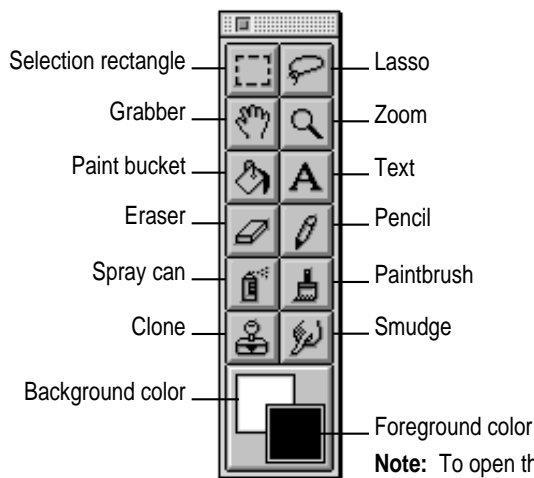

**Note:** To open the Macintosh Color Picker, click the foreground color (or Option-click the background color). You can use the Color Picker to design the colors you want.

### Brush palette

Use the brushes to set the shape for the painting tools. The brush shape you choose affects the selected tool (spray can, paintbrush, clone, and smudge).





## Color palette

Use the color palette to change the color that you apply with the pencil, brush, bucket, or spray can in the foreground, or to select the color that appears when you use the eraser in the background.

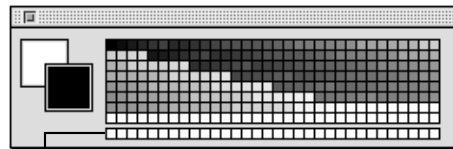

To change the color you apply in the foreground, click the color you want.

To change the color in the background when you erase, Option-click the color you want.

To create custom colors, double-click a swatch.  
In the Color Picker that appears, select the color you want.

To choose a paint color from an image:

- 1 Select the pencil, brush, bucket, or spray can, press Option, and then click in the image.**

The foreground indicator shows the color you clicked. You can drag the eyedropper anywhere in the image, changing the foreground color as you go.

- 2 When you find the color you want, release the Option key.**

You can now use the pencil, brush, bucket, or spray can to apply the newly chosen color.

## Showing and hiding the palettes

You can hide the palettes without quitting the application.

- To hide the palette, click the close box.

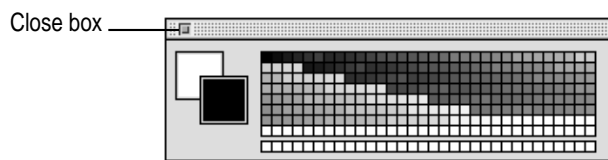

- To show a palette, choose Show Tools, Show Brushes, or Show Colors from the Window menu.

## Selecting images

When you select a portion of an image, you can move, cut, copy, or manipulate the selection.

### Regular shape

To select a rectangular part of an image:

- 1 Click the selection rectangle.
- 2 Drag the tool over an area to select that area.

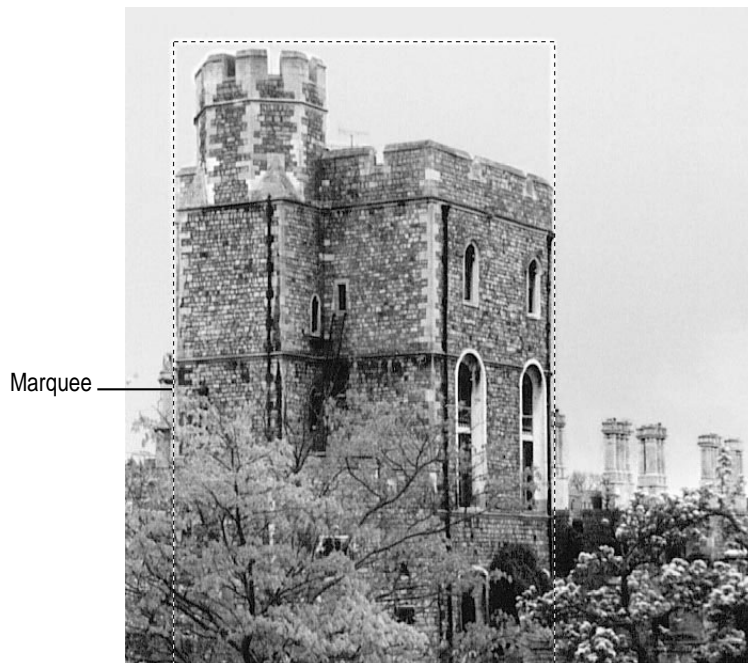

The area you dragged over is surrounded by a marquee (a dashed line), which indicates selection.

## Irregular shape

To select an irregular shape:

- 1 **Click the lasso.**
- 2 **Drag the lasso to trace an area around the shape you want to select.**



When you release the mouse button, the marquee takes the irregular shape you made.

## Whole image

To select the whole image:

- **Choose Select All from the Edit menu (or press ⌘-A).**

A marquee surrounds the whole image.

To deselect the whole image:

- **Choose Deselect from the Edit menu.**

## Using the tools to edit an image

Each tool on the tool palette has a special purpose: making a selection, adding text, painting, and so on.

### Using a tool

To use a tool:

- Click the tool to make it active.

### Moving a selection

To move a selection around within the image:

- To drag the selection, use the tool you used to make it (the lasso or the selection rectangle).



The building was moved to cover the sheds.

## Zooming in

To zoom in close:

- Click the magnifying glass and then click a spot in the image.

The image is enlarged.

To zoom back out:

- With the magnifying glass still selected, press Option and click the image.

You can also choose Zoom In or Zoom Out from the Image menu.

## Filling a space with color

To fill a space with color:

- 1 Click the paint bucket.
- 2 Click a color on the color palette.

The foreground color changes to the color you clicked.

- 3 Click the space you want to fill.

The space fills with the foreground color.



## Adding text

To type some text in the image:

- 1 Click the text tool.
- 2 Click the part of the image where you want to add text.
- 3 In the dialog box that appears, type the text you want.

You can also use the dialog box to choose the font you want, its size, style, and color.

- 4 When you've got the text the way you want it, click OK.

The text appears in the image.

## Erasing a selection

To erase parts of the image:

- 1 Click the eraser.
- 2 Drag the eraser over the areas you want to erase.

The area you drag over fills with the background color.

*Note:* On 68000 series Macintosh computers, the eraser takes longer to work.



The eraser tool was used to create a black border.

## Drawing lines

To draw fine lines or shapes in the image:

- 1 **Select the pencil.**
- 2 **Drag the pencil through the image to add the shapes or lines.**

You can also zoom in and click individual pixels.

*Tip:* To create a horizontal or vertical line, press Shift as you drag. To change the size of the pencil line, use the brush palette.

## Spray painting

To spray paint:

- 1 **Select the spray can.**
- 2 **Drag the spray can across the image.**

The paint leaves a stroke in the foreground color.

*Tip:* To change the size of the spray can stroke, use the brush palette.

The spray can was used to add definition to the edges of the petals.



*Note:* On 68000 series Macintosh computers, the spray can takes longer to work.

## Painting with brushes

To paint with strokes of various sizes:

- 1 **Select the brush.**
- 2 **Click one of the brush sizes on the brush palette.**
- 3 **Drag the brush to paint in the foreground color.**

## Cloning

A *clone* is a duplicate of a small part of an image. You can use the clone to edit flaws in an image, painting it into an image at a different location.

When you paint the clone back in, the painting starts at a reference point that you define. This is easier to do than to explain, but here is an example.

*Example:* Suppose you've scanned a picture of a building and you want to cover a certain feature, such as a fountain, with another portion of the image, such as a group of shrubs. You want to repeat the shrub portion of the image without the sharp cut-out image of a copied-and-pasted selection.

To clone an image and repeat it:

- 1 **Click the clone tool.**



- 2 Press the Option key and then click the spot you want to serve as a reference point for the clone.**

In the example, you'd click a point in the shrubbery.



Option-click here (for example), so you can clone the shrubbery and cover up the fountain spray.

- 3 Move the clone tool over the point at which you want the image to begin repeating, then start dragging.**

In the example, you'd start dragging (painting) at a point somewhere near the fountain. As you drag, the image begins to appear, starting with the reference point.



The clone appears as you paint.

The reference point that is duplicated

As you extend the painting, the rest of the cloned image appears—or as much of it as you want to paint.

*Tip:* For a more natural appearance, reposition the reference point from time to time. To do this, press the Option key and click the new spot you want to clone.

## Smudging

To smudge colors and lines into other colors and lines:

- 1 **Select the smudge tool.**
- 2 **Drag through colors and lines.**

The tool takes colors with it as you drag, much the same way your fingers smear wet paint when you paint with your fingers.



Colors smear  
as you drag.

## Copying, cutting, or deleting a selection

You may want to copy part or all of an image and paste it into a word-processing or desktop publishing document.

### Copying within an image document

To copy and paste a selection within an image document:

- 1 **Select the area you want to copy.**
- 2 **Choose Copy from the Edit menu (or press ⌘-C).**
- 3 **Click anywhere in the image area and choose Paste from the Edit menu (or press ⌘-V).**

The copy is pasted where you clicked.

### Copying and pasting into another application

To copy and paste a selection into a document in another application:

- 1 **Select and copy a portion of an image as described in the previous steps.**
- 2 **If the other application is running and the document is open, click the document to activate it.**

You can open another application and create a new document without losing the contents of the Clipboard. The copy you made remains on the Macintosh Clipboard until you copy something else.

- 3 **Set the insertion point in the document and choose Paste from the Edit menu (or press ⌘-V).**

The copy is pasted into the document.

*Note:* Some publishing applications do not allow you to paste the selection.

## Cutting

To cut a selection from an image:

- 1 **Select the area you want to cut.**
- 2 **To store a temporary copy of what you cut on the Clipboard, choose Cut from the Edit menu (or press ⌘-X).**
- 3 **To remove the selection without storing a temporary copy of it, press the Delete key.**

This completely erases the selection. You cannot paste a copy elsewhere.

## Undoing an action

You can reverse an action if you do so before you take another action. For example, if you press the Delete key to delete a selection, you can restore what you cut if the cut was the most recent editing action you took.

To undo an action:

- **Immediately choose Undo from the Edit menu (or press ⌘-Z).**

## Zooming in and out

Sometimes you may need to work closely with an image or back away from it to get an overview. A closer view makes it easier to work with details. A more distant view makes it easier to work with an image as a whole.

To zoom into and out of an image:

- 1 **Choose Zoom In or Zoom Out from the Image menu.**

**Zoom In** Takes you closer to the image; elements of the image appear larger.

**Zoom Out** Takes you farther away from the image; elements of the image appear smaller.

- 2 **To return to a 100-percent view, choose Actual Size from the Image menu.**

Changes you make with these commands don't affect the size of the actual image.

## Inverting an image from positive to negative

You can change a positive image to a negative image, or a negative image to a positive image.

To invert an image:

- Open the image and choose Invert from the Image menu.



## Adjusting the brightness and contrast

You can adjust the brightness and contrast of images. You may want to do this when an image is too dark or does not show sharp enough differences between dark and light colors.

To adjust brightness and contrast:

- 1 **Choose Brightness/Contrast from the Image menu.**

The Brightness/Contrast dialog box opens.



- 2 **Drag the sliders to the settings you want.**

You can see the effects of the changes on the image.

- 3 **Click Reset to return the settings to zero and leave the dialog box open.**
- 4 **Click OK to save the changes and close the dialog box.**

## Changing the color balance

You can change the color balance in an image by adjusting color values for shadows (darker areas), midtones, and highlights (brighter areas).

To adjust color balance:

- 1 **Open the image you want to adjust.**
- 2 **Choose Color Balance from the Image menu.**

The Color Balance dialog box opens.



Click a color to change the foreground color.

Option-click to change the background color.

- 3 **Click Shadows, Midtones, or Highlights to specify the level of color you want to modify.**
- 4 **Drag a slider to adjust a color value.**

The numeric values in the Red, Green, and Blue boxes change as you drag the sliders for Cyan, Magenta, and Yellow.

*Example:* When you drag the Cyan slider toward the right, you increase Red to a value between 1 and 100, and you decrease the Cyan value. When you drag the Cyan slider toward the left, you reduce the Red value to a negative number (from -1 to -100) and increase the Cyan value.

As soon as you adjust a color, the image is updated to show the change.

- 5 **To change your mind and return the image to its original color balance, click Reset.**

The image reverts to the original color balance, but the dialog box remains open.

- 6 **Click OK to confirm your changes, or click Cancel to close the dialog box without applying your changes.**

## Sharpening an image

You may notice that the edges of an image are softer than you want them to be. Or, you may want to soften edges that look too sharp.

To sharpen an image:

- **Choose a command from the Sharpen submenu in the Image menu.**

Commands in the Sharpen submenu add definition to an image. If an image looks softer than you want it to look, the Sharpen commands may help. You may not notice much difference on the screen.

**A Little** Has an almost imperceptible effect.

**A Lot** Has a significant effect.

**Unsharp Masking** Opens the Unsharp Masking dialog box:



Options in the Unsharp Masking dialog box adjust the contrast of image details to create the illusion of a sharper image.



**Amount** The amount determines what percentage of change will occur. The default setting is 50 percent. Increase up to 100; decrease down to 1. A higher percentage makes the effect stronger.

**Radius** The radius determines the depth of pixels that are affected at the edge you're changing. The default setting is 25 pixels. Increase up to 100; decrease down to 0.1. A larger radius causes more of the pixels surrounding the edge pixels to be sharpened.

**Threshold** Threshold determines the level of brightness to be used for differentiation. The default setting is 0 levels. Increase up to 25. A lower value produces a more pronounced effect.



Amount 50  
Radius 25  
Threshold 0



Amount 75  
Radius 75  
Threshold 0



Amount 100  
Radius 50  
Threshold 1



Amount 100  
Radius 100  
Threshold 25

## Resizing an image

You can set a specific size for an image.

To resize:

- 1 **Open the image and choose Resize from the Image menu.**

The Resize dialog box opens.

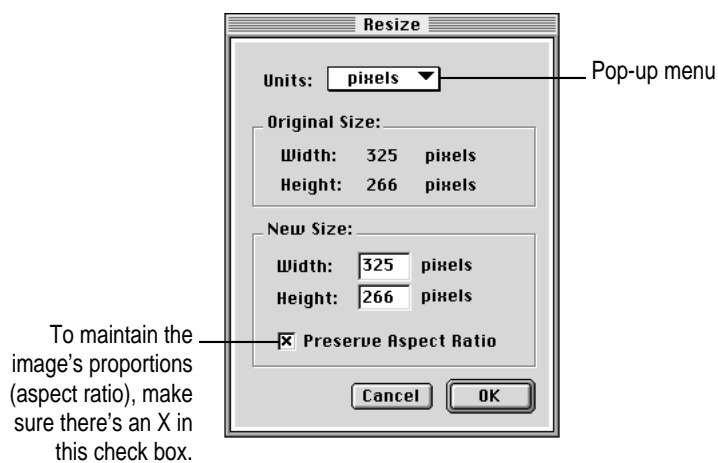

- 2 **Choose the units you want to use from the Units pop-up menu.**
- 3 **Type the new size and click OK.**

The image is resized to fit your settings.

## Cropping an image

You can select an area of an image and then eliminate the surrounding area.

To crop an image:

- 1** Select the area you want to remain in the image.
- 2** Choose Crop from the Image menu.

The area around the selection is deleted.



## Flipping an image

Sometimes you may inadvertently scan an image upside down or on its side. You can correct this situation by flipping the image.

To rotate a selection:

- 1 **Open the image.**
- 2 **From the Image menu, choose an option from the Flip pop-up menu.**

**Vertical** Flips the image vertically (upside down)



Original



Flip vertical

**Horizontal** Flips the image horizontally (from right to left)



Original



Flip horizontal

## Rotating an image

- 1 From the Image menu, choose an option from the Rotate pop-up menu.

You can rotate the image 90 degrees left, 90 degrees right, or 180 degrees. You can also choose Arbitrary rotation and set the number of degrees.



90° left rotation



90° right rotation



180° rotation

- 2 If you want to specify the degree of rotation, choose Arbitrary to open a dialog box.

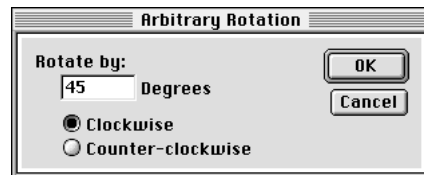

- 3 Type the number of degrees you want and click OK.



Original



45° right rotation

## Setting the image depth

You can change the number of colors used in an image or switch a color image to black and white. You do this by changing the image depth.

To change depth:

- From the Image menu, choose an option from the Image Depth submenu:

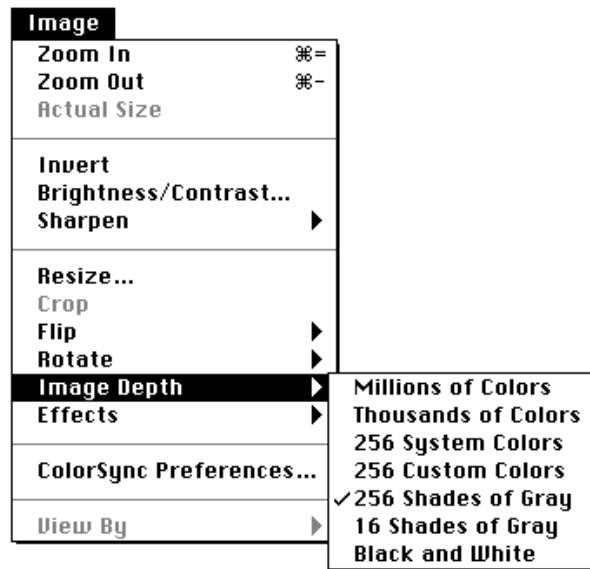

If you change the depth of an image to fewer colors or grays, you cannot recover the original image depth. You must rescan the original to get back the higher number of colors.

## Setting ColorSync preferences

Different devices—scanners, printers, and monitors, for example—reproduce different ranges of colors. ColorSync is a color management system that allows applications and device drivers to produce consistent color across different devices.

ColorSync stores information about various devices in profiles. *Profiles* are dictionaries that contain color information about a specific device. ColorSync is an Apple system extension. You can switch ColorSync on and off and select the appropriate ColorSync profile for your scanner when necessary.

To set ColorSync preferences:

- 1 **With the OneScanner Dispatcher application open, choose ColorSync Preferences from the Image menu.**

The ColorSync Preferences dialog box opens.

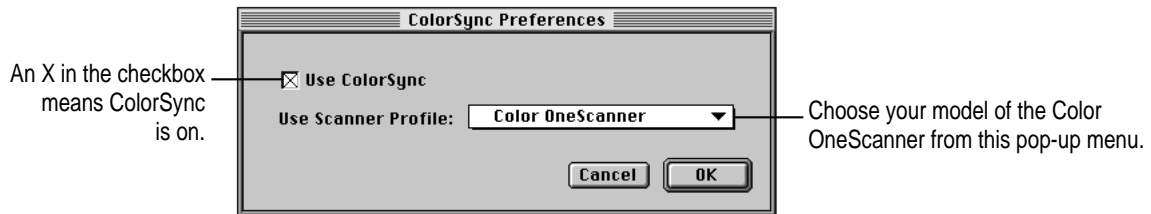

- 2 **To switch ColorSync on, click to place an X in the Use ColorSync box.**
- 3 **Choose the scanner model you want to use from the Use Scanner Profile pop-up menu.**

If you are using the optional Transparent Media Adapter with the Color OneScanner 1200/30, choose the ColorSync profile for the medium you are scanning:

- Color OneScanner Flatbed for magazines, paper, other opaque originals
- Color OneScanner Positive for positive transparencies
- Color OneScanner Negative for negatives

Without the correct profile, you may not be satisfied with the resulting image quality. If you change media, be sure to change the ColorSync profile.

- 4 **Click OK to close the dialog box, or click Cancel to leave preferences the way they were.**

## Changing the way you view an archive

Occasionally you may want to view thumbnails in order by type, date, or size rather than by name.

To change the view:

- 1 **Open the archive you want to look at.**
- 2 **From the Image menu, choose an option from the View By submenu: Name, Date, Type, or Size.**

The order of thumbnails in the archive changes to the option you chose.



# 6

## Scanning Text

An optical character recognition (OCR) program such as Xerox TextBridge analyzes scanned text and converts each character into a form of text a computer can recognize.

This chapter is a brief introduction to text scanning. You'll learn

- how to scan a text document for use with the TextBridge application
- how to use the OneScanner Dispatcher application to send a saved text image to the TextBridge application

Be sure you use the version of TextBridge that comes with your scanner. This version has an OCR-to-HTML converter so you can save files in HTML format.

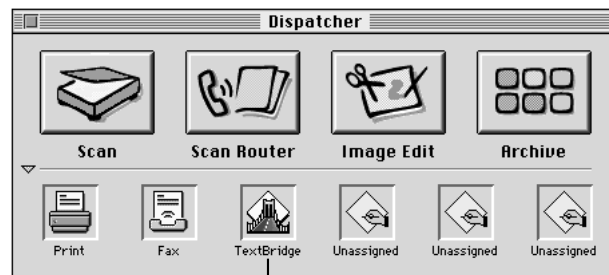

Xerox TextBridge application  
in a drag-and-drop icon

## Scanning a text document into the TextBridge application

You'll find OCR scanning especially useful if you have many documents that need to be moved onto the computer for storage or information-retrieval (search) purposes.

After the text is converted, you can copy and paste—or import—the text into a word-processing or desktop publishing document. There you can edit and revise the text without retyping.

To use TextBridge, you must complete two procedures:

- First install the TextBridge software, following instructions in the user's manual for TextBridge.
- Then you must assign TextBridge to the Dispatcher. For instructions, see “Assigning the Xerox TextBridge 30H Application to the Dispatcher” in Chapter 3 of this manual.

*Optional Automatic Document Feeder:* An optional Automatic Document Feeder is available from your authorized Apple dealer. This device increases productivity by automatically feeding up to 20 pages into the scanner. If you already have an Automatic Document Feeder, see Chapter 9, “Using the Automatic Document Feeder,” for information on setup, use, and maintenance.

To scan for OCR:

- 1 Put the text original on the scanner glass and close the scanner cover, or place the originals in the document feeder.
- 2 If necessary, start the OneScanner Dispatcher application by double-clicking its icon.

The Dispatcher window opens:

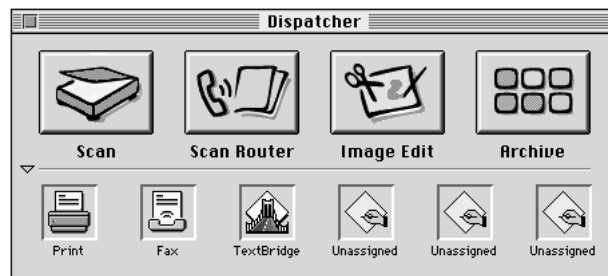

- 3 Click Scan to open the Apple Color OneScanner dialog box.
- 4 Choose Flatbed from the Source pop-up menu; if you're using the document feeder, choose Feeder.
- 5 Choose Black and White from the Image pop-up menu, and choose 300 dpi from the Resolution pop-up menu.
- 6 Click Scan.  
The original document is scanned.
- 7 Choose Save from the File menu.  
The Save dialog box opens.
- 8 Choose TIFF from the File Format pop-up menu.

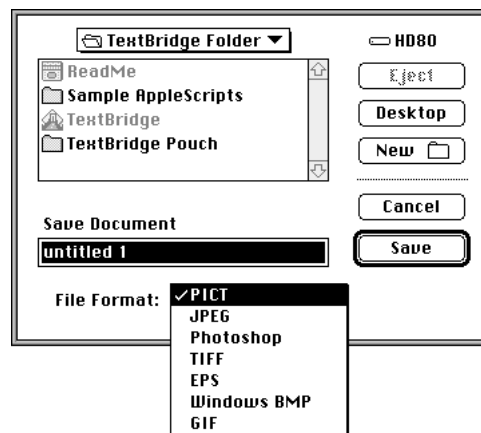

TIFF is the recommended format for text images.

For information on saving an image and choosing a file format, see “Saving a Scanned Image” in Chapter 4.

- 9 Click Save.
- 10 In the TIFF Options dialog box that appears, click Compressed.

When you've scanned a few pages, you can use the drag-and-drop OCR icon, as described in the next topic, to send the text to TextBridge.

## Moving a text image to the TextBridge application

After a text image is scanned, you can rename it or accept the automatically numbered image. When you've scanned and saved an image, you can send the image to the TextBridge application.

*Note:* You can use TextBridge as a stand-alone application. It is not required to use it through the Color OneScanner Dispatcher.

To send a saved text image to TextBridge:

- 1 If necessary, open the Dispatcher window.

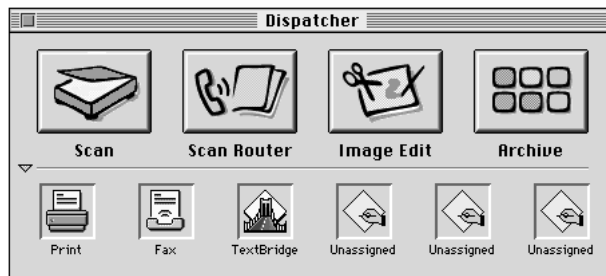

- 2 Click Archive and open the archive that contains the image you want to send to the TextBridge application.

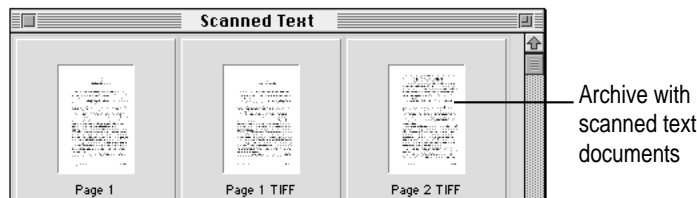

- 3 Drag the text thumbnail from the archive onto the TextBridge icon on the bottom panel of the Dispatcher window.

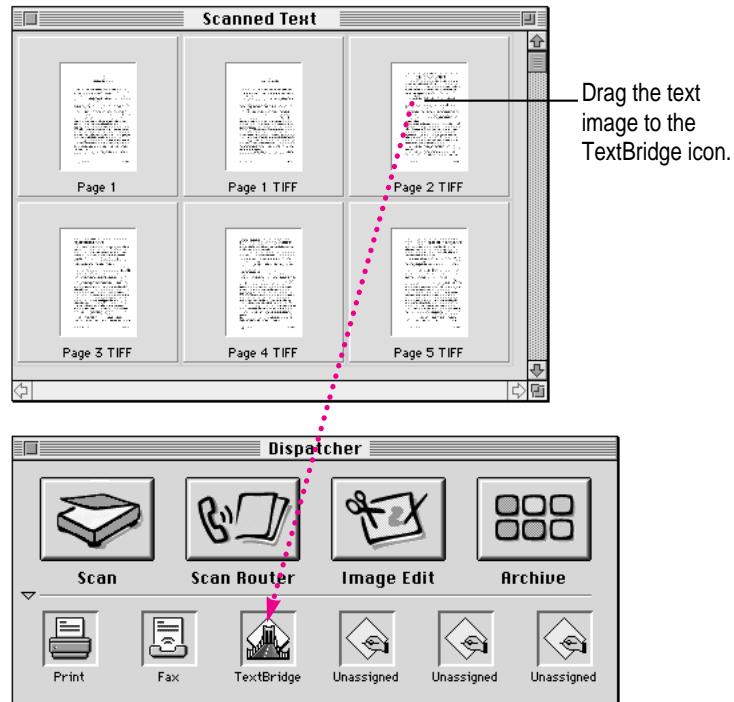

The TextBridge dialog box opens.

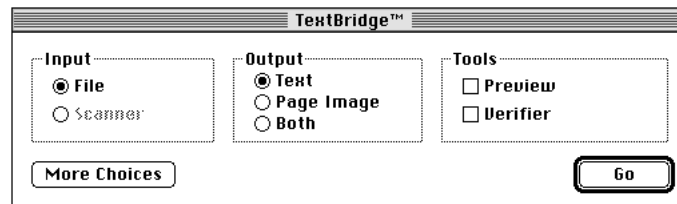

- 4 Click Go.
- 5 See your TextBridge manual for information about the next steps.

In the TextBridge application, the image is converted to text. You can now move the text into a word-processing, page-layout, or desktop publishing document for editing.

## Converting a text image into an HTML document

When you've scanned and saved a text image (in TIFF or PICT format), you can convert it to an HTML file for use on the Internet.

- 1 If necessary, open the Dispatcher window.**
- 2 Click Archive and open the archive that contains the image you want to convert to HTML.**
- 3 Drag the thumbnail of the text image from the archive to the TextBridge drag-and-drop icon.**

This opens the TextBridge application.

- 4 In the TextBridge dialog box that appears, make the selections you want.**

For an explanation of the features, see your TextBridge manual.

- 5 When the TextBridge settings are what you want, click Go.**

Depending on what you chose in TextBridge, you may have to click a Continue button one or more times to get to the next step.

- 6 In the "Add pages and continue" dialog box, select your document and click Continue.**

- 7 In the Save Output As dialog box that appears, select a Dispatcher archive folder, choose HTML from the Text pop-up menu, type a name for the file, and click Continue.**

TextBridge optical character recognition converts the file to text and saves the image in HTML format.

- 8 When you are finished converting images, quit the TextBridge application.**

The document appears as an HTML thumbnail in the Dispatcher archive. You can now drag and drop the HTML thumbnail to applications in the Dispatcher that support and read HTML files, such as web-authoring applications.

*Note:* TextBridge converts images to text and saves them as HTML files but does not read HTML files.

# 7

## Dispatcher Commands



This chapter explains what happens when you choose any of the commands in the OneScanner Dispatcher menus. The chapter

- provides a quick reference for advanced users
- shows dialog boxes opened by various commands and explains their functions, but does not provide step-by-step instructions

The chapter is organized by menu.

## File menu

Commands in the File menu control activities at a document level. For example, you use File menu commands to create and save documents and to set up a document for printing.

File	
<b>New Scan...</b>	<b>⌘N</b>
<b>New Image...</b>	<b>⌘G</b>
<b>New Archive...</b>	<b>⌘J</b>
<b>Open Image...</b>	<b>⌘O</b>
<b>Open Archive...</b>	<b>⌘H</b>
<b>Scan Router...</b>	
<b>Close</b>	<b>⌘W</b>
<hr/>	
<b>Get Info...</b>	<b>⌘I</b>
Save	<b>⌘S</b>
<b>Save As...</b>	
Revert	
<hr/>	
<b>Page Setup...</b>	
<b>Print...</b>	<b>⌘P</b>
Print Archive View	
<hr/>	
<b>Quit</b>	<b>⌘Q</b>

For information about opening images and archives, see Chapter 4, “Scanning Images.”



## New Scan

Opens the Apple Color OneScanner dialog box.

For information about this dialog box, see “Scanning with Automatic Settings” and “Scanning with Custom Settings” in Chapter 4.

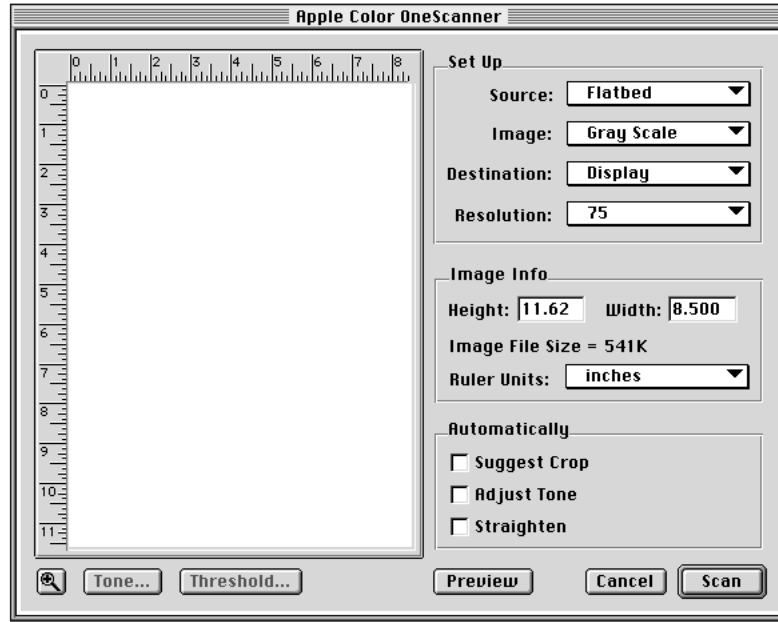

## New Image

Opens the New Image dialog box. You can specify a size, resolution, and image depth for the new image.

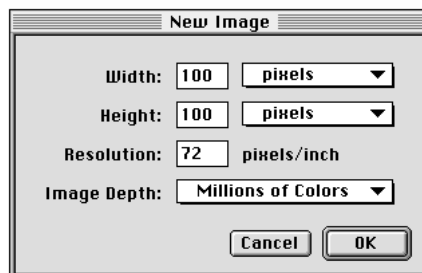

## New Archive

Opens the New Archive dialog box. You can name the new archive and save it in a folder of your choice.

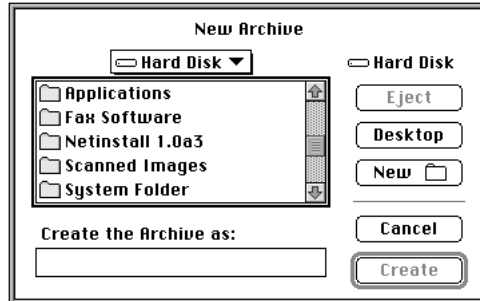

## Open Image

Opens a file dialog box where you can select and open a saved image.

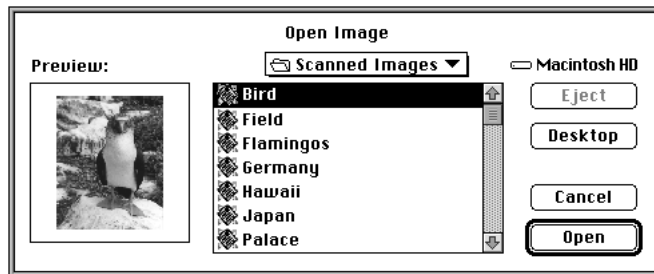

For information about opening images, see “Opening a Saved Image From an Archive” in Chapter 4.

You use this dialog box to switch through folders and to find, select, and open scanned images.

## Open Archive

Opens a file dialog box where you can switch through folders to find, select, and open the archive that contains the images you want.

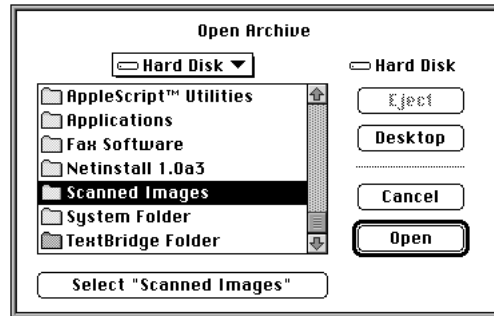

For information about opening an archive, see “Opening a Saved Image From an Archive” in Chapter 4.

## Scan Router

Opens the Scan Router dialog box, which gives you a choice between faxing or printing (copying) the original document.

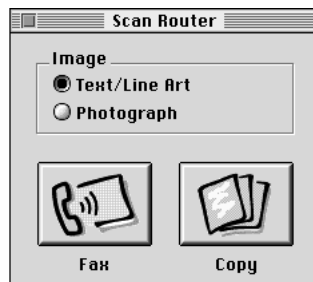

For information, see “Faxing or Printing Directly From the Scanner” in Chapter 4.

**Text/Line Art** Tells the scanner you are about to fax or copy an image.

**Photograph** Tells the scanner you are about to fax or copy a complex photographic image.

## Close

Puts away the active window. If you haven’t saved an image, or any changes you’ve made, an alert box appears. You’re asked if you want to save the image before you close it.

## Get Info

Opens a dialog box that provides detailed information about a selected image, such as size, date created and modified, and image depth.

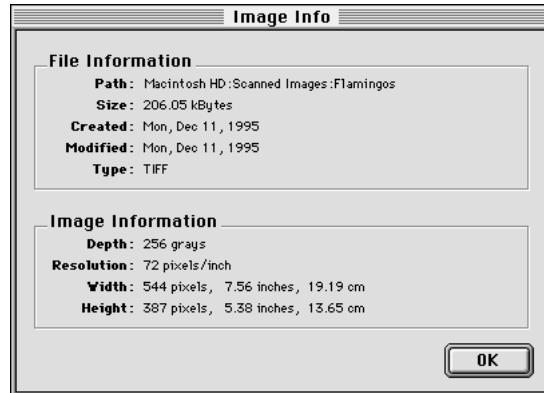

## Save

Saves an image you've scanned, including any changes you have made to it.

If this is the first time you've saved the image, the Save As dialog box opens. You can choose a file format for the image. The format you choose depends on the requirements of the application into which you plan to import that image.

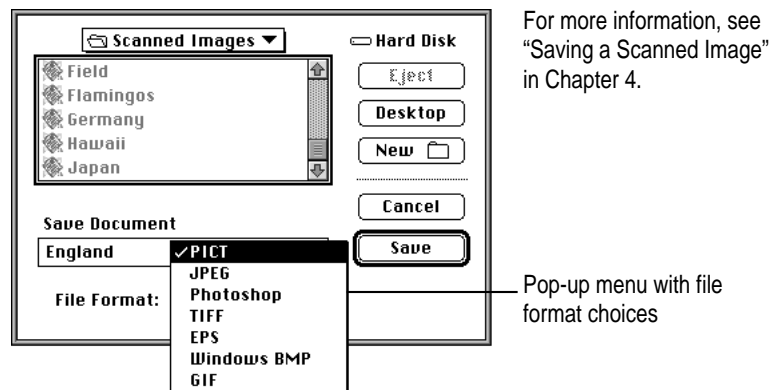

## Save As

Use the Save As command to save a document with a different name, in a different folder, on a different disk, or in a different format—or all of the above.

## Revert

Returns a document to its last saved version.

## Page Setup

Opens the Page Setup dialog box (yours may look different):

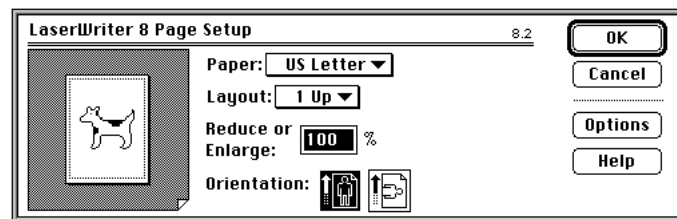

For information about page setup options, see the manual that came with your printer.

Options in the Page Setup dialog box determine page size, orientation, and other options before you print.

## Print

Opens the Print dialog box (yours may look different):

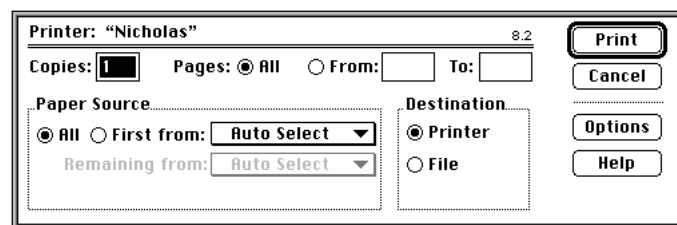

For information about printer settings, see the manual that came with your printer.

Options in the Print dialog box control how many copies to print, how many pages and which pages, and other printing-related options—including color. When you print photographic images, be sure to choose Color/Grayscale.

## Print Archive View

Prints an archive, with thumbnails.

## Quit

Ends a session with the OneScanner Dispatcher application. If you haven't saved any images now open, a message appears to ask you if you want to save the image before you quit the application.

## Edit menu

Edit	
Undo	⌘Z
Cut	⌘H
Copy	⌘C
Paste	⌘U
Clear	
Select All	⌘A
Deselect	

For information about editing images, see Chapter 5, "Editing Scanned Images."

You use commands in the Edit menu to revise image documents by cutting, copying, and pasting selected colors and shapes.

## Undo (Redo)

Cancels or reapplies your most recent change to the scanned image (Undo). For example, if you used the eraser tool and erased the wrong thing, you can choose Undo to cancel the erasure. Redo restores the change you undid.

## Cut

Removes the material you have selected and places it on the Clipboard.

## Copy

Copies to the Clipboard the material you have selected. The original image stays where it was when you selected it.

## Paste

Copies the material on the Clipboard to the center of the document window (where you can move it around as you wish). You can continue to paste copies until you cut or copy a new selection (which replaces the contents of the Clipboard).

## Clear

In an image, removes the selection without placing it on the Clipboard. (The contents of the Clipboard, if any, stay intact.) In an archive, Clear deletes a selected image.

## Select All (Deselect)

Selects the whole image (Select All), or cancels a selection (Deselect).

## Image menu

Commands in the Image menu control the way you view an image and the way an image looks.

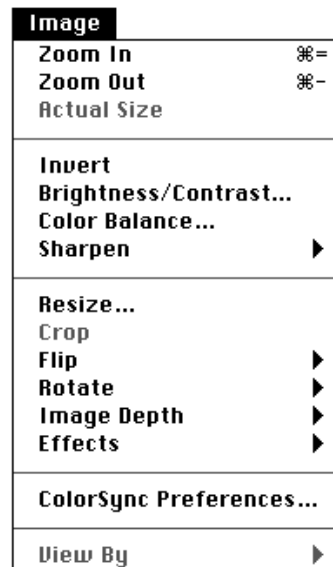

## Zoom In

Enlarges the image on the screen. Changes you make with this command don't affect the size of the printed image. You can also use the zoom tool. Press Option to switch the tool between zooming in and zooming out.

## Zoom Out

Reduces the image on the screen. Changes you make with this command don't affect the size of the image when you print.

## Actual Size

Returns the image to the standard view, a pixel-for-pixel representation, neither enlarged nor reduced.

## Invert

Creates a negative image from a positive image, or vice versa.

## Brightness/Contrast

Opens the Brightness/Contrast dialog box. Options in the dialog box give you more precise control of how bright or dark an image appears.



For more information, see “Adjusting the Brightness and Contrast” in Chapter 5.

## Color Balance

Opens the Color Balance dialog box, where you can adjust color values in a saved image. For information, see “Changing the Color Balance” in Chapter 5.



## Sharpen

Opens a submenu you can use to change the definition of an image. If an image looks too soft, use the Sharpen commands to adjust the image.

The Unsharp Masking command opens a dialog box:



For more information, see "Sharpening an Image" in Chapter 5.

## Resize

Opens the Resize dialog box.

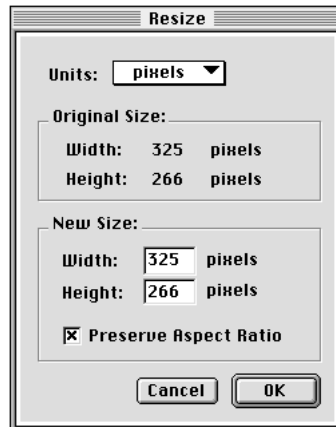

For information about using this dialog box, see "Resizing an Image" in Chapter 5.

## Crop

Cuts off parts of an image that are outside the selection marquee.

## Flip

Opens a submenu that gives you the choice of flipping the image vertically (upside down) or horizontally (right to left).

## Rotate

Opens a submenu that gives you the choice of rotating an image 90 degrees left, 90 degrees right, or 180 degrees. The Arbitrary command opens a dialog box.

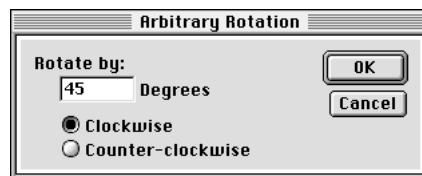

For more information, see "Rotating an Image" in Chapter 5.

## Image Depth

Opens a submenu from which you can choose the number of colors you want to use to view your images.

## Effects

Once your Photoshop-compatible plug-in filters are installed in the Apple Color OneScanner Plug-Ins folder, they appear in the Effects submenu and can be applied to your images.

## ColorSync Preferences

Opens the ColorSync Preferences dialog box.

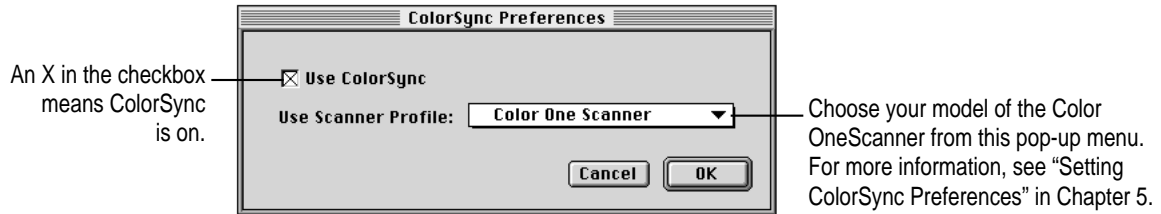

The pop-up menu in this dialog box specifies the device used for ColorSync settings.

## View By

Changes the way you see documents listed in an archive. You can view documents by name, type, date, or size.

## Window menu

You use commands in the Window menu to show and hide the Dispatcher window and open images.

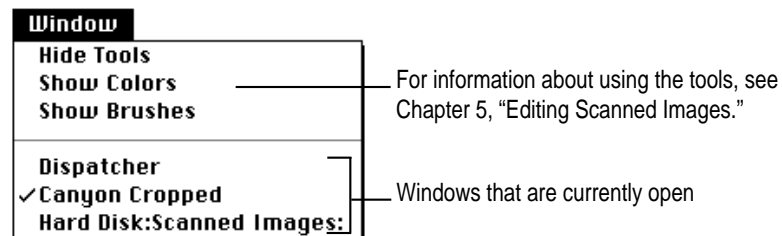

## Hide (Show) Tools

Shows or hides the tool palette.

## Hide (Show) Colors

Shows or hides the color palette.

## Hide (Show) Brushes

Shows or hides the brush palette.

## Dispatcher

Shows or hides the Dispatcher window.

## Image-editing tools

### Tool palette

The tool palette provides tools you use to edit scanned images.

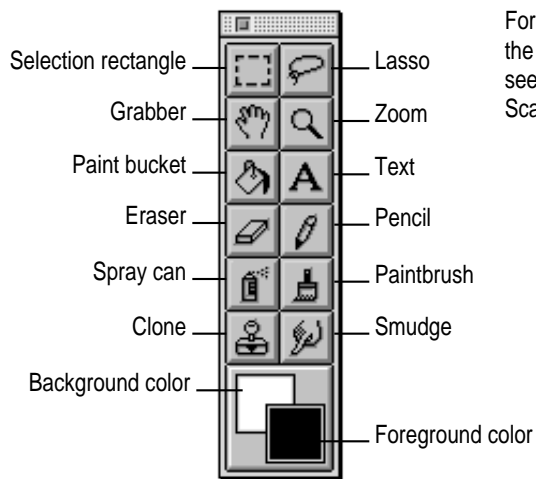

For information about using the tools to edit images, see Chapter 5, "Editing Scanned Images."

**Selection rectangle** Selects a rectangular or square area so you can crop, copy, cut, or clear the selection.

**Lasso** Selects an irregular portion of an image so you can copy, cut, or clear the selection.

**Grabber** When an image is larger than its window (and the scroll bars are active), you can use the grabber to move the image inside the window.

**Zoom** Gives you a closer or more distant view of an image.

**Paint bucket** Fills an area of the image with the foreground color.

**Text** Lets you add text to an image.

**Eraser** Clears parts of an image when you drag the eraser over the image. The color left by the eraser is the background color.

**Pencil** Adds individual dots to an image. If you drag the pencil across the image, the dots appear to be a line. Zoom in to edit individual dots.

**Spray can** Applies soft strokes of paint in the shape of the brush you choose.

**Paintbrush** Applies the current foreground color when you drag the tool. You can change the shape by clicking a different shape on the brush palette.

**Clone** Creates a duplicate of an image that you can paint elsewhere in the same image or in another image.

**Smudge** Simulates the way you drag a finger through wet paint.

## Color palette

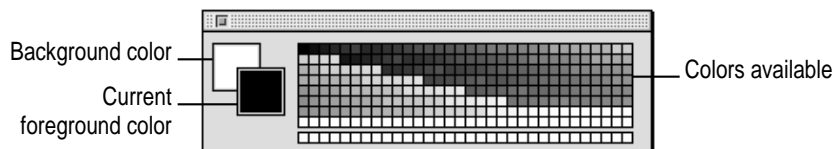

You use the color palette to change the foreground and background colors and to create custom color swatches. For information, see “Image-Editing Overview” in Chapter 5.

## Brush palette



You use the brush palette to change the size of the painting tools (the pencil, spray can, paintbrush, clone, and smudge tools).



# 8

## Scanner Maintenance



Your Apple Color OneScanner needs little maintenance, except for occasional cleaning. Follow the guidelines in this chapter to keep the scanner working properly.

### Cleaning the scanner

To clean the scanner:

- 1 **Switch off the scanner and computer.**

**WARNING** Do not attempt to service the scanner yourself. Disassembling the scanner can expose you to dangerous voltage points or other risks. If you think your Apple Color OneScanner needs servicing, call your authorized Apple reseller to find the service center nearest you.

- 2 **Unplug the scanner power cord from the wall outlet.**
- 3 **Dampen a cloth with water or a mild cleaning agent, and then thoroughly wring out the cloth.**
- 4 **Use the cloth to gently wipe clean the document glass, the scanner cover, and exterior surfaces.**

Don't tip the scanner on its side or turn it upside down. To move the scanner, follow the guidelines in "Carrying the Scanner" in Chapter 2.

**WARNING** Avoid spraying cleaning agents or water directly on the document glass. The spray could penetrate below the glass and contaminate internal mirrors and lenses.

Never use a chemically treated cloth or cleaners that contain alcohol, benzene, or ammonia. Use of such items can discolor, deform, or melt the outside covering. Do not lubricate the scanner.

- 5 Dry the damp areas with a clean, soft, dry cloth.
- 6 Use a clean, soft, dry cloth to remove any dust or debris from the power cord socket, interface connectors, and other metal parts.



# 9

## Using the Automatic Document Feeder



The Apple Automatic Document Feeder is an optional accessory you can purchase to automate the scanning of multiple original pages. You'll find the Automatic Document Feeder especially useful if you plan to use your scanner for optical character recognition (OCR) or repetitive image retrieval work.

This chapter shows you how to set up and use the document feeder. You'll find instructions for

- hardware setup
- loading of multiple original pages
- maintenance and troubleshooting

### Setting up the Automatic Document Feeder

Setting up the Automatic Document Feeder is a simple process that requires no special tools. After installation, the document feeder works as the top cover of the scanner. If you find later that you don't need the feeder, you can easily remove it and replace it with the original scanner cover.

*Set up the scanner first:* Before you connect the Automatic Document Feeder to your scanner, you need to set up the Apple Color OneScanner and install the scanner software. See Chapters 2 and 3 for instructions if you haven't yet set up the scanner hardware and software.

To connect the document feeder:

- 1 Switch off the scanner and then switch off your Macintosh computer.**

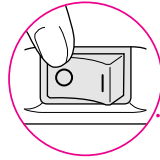

Power switch.  
“O” is off and  
“I” is on.

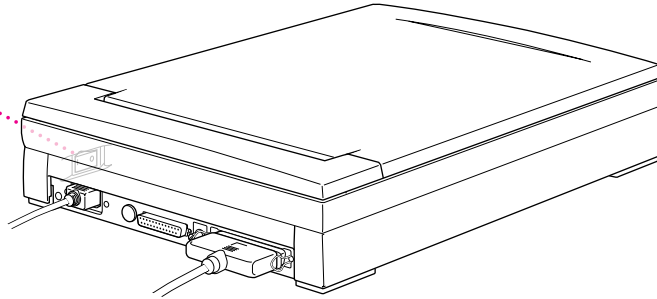

Devices connected through SCSI cables require a certain power-on sequence. See “Switching the Power On,” in Chapter 2, for more information.

- 2 Grip the scanner top cover on both sides and lift it off.**

Put the original cover away in a safe place for future use. The document feeder replaces the cover.

Grasp cover here.

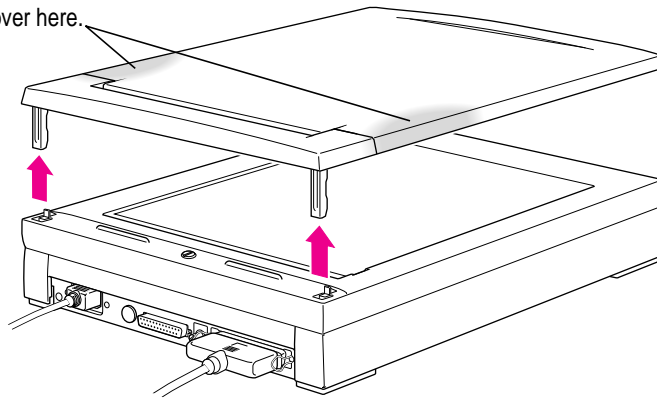

**3 Install the Automatic Document Feeder.**

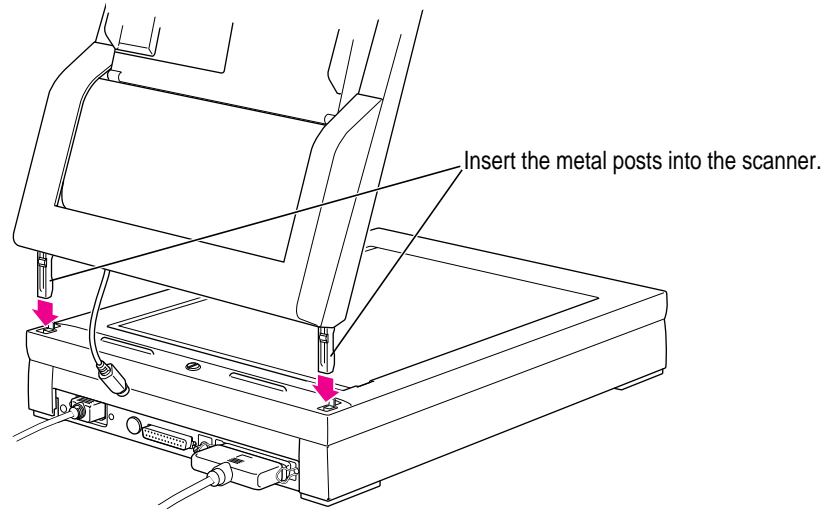

**4 Close the document feeder by gently pushing it downward.**

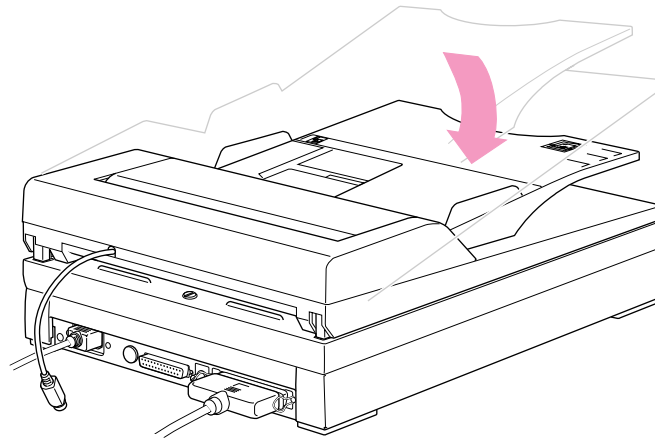

- 5 Remove the plastic cap from the port on the back of the scanner and put it in a safe place.

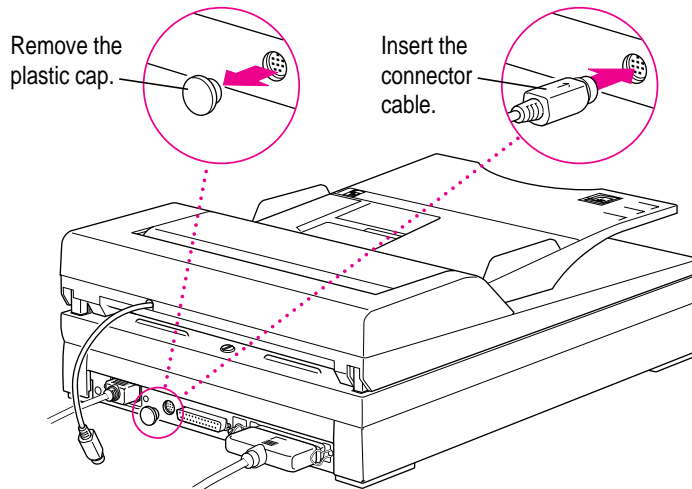

- 6 Plug the cable from the document feeder into the small port on the back of the scanner.
- 7 Switch on the scanner and then switch on your Macintosh.

The scanner makes some sounds as it warms up. After about 20 seconds, the document feeder and scanner are ready to use.

## Automatic Document Feeder at a glance

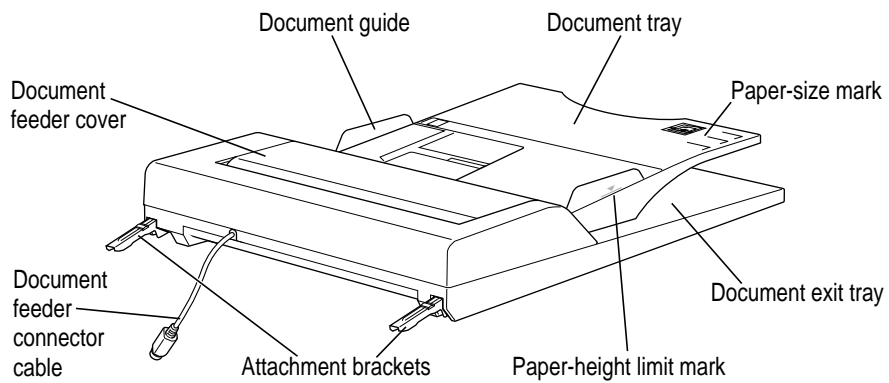

## Choosing originals to scan

The document feeder is designed to accept standard office papers as originals. Like a copy machine, the document feeder may have problems with bent, torn, or otherwise mutilated originals.

### These originals work best

The document feeder accepts paper with the following dimensions and weight:

- paper size
  - length*                    10 1/8 to 14 in. (257 to 356 mm)
  - width*                    7 3/16 to 8 1/2 in. (182 to 216 mm)
- paper weight        16 to 20 lb. bond (60 to 160 g/m<sup>2</sup>)

### These originals may cause trouble

The document feeder will not work well with

- originals with tears, perforations, or punch holes
- curled or wrinkled originals
- carbon-backed originals or originals on coarse paper
- labels or postcards
- thick, taped, or glued originals

Such originals will work fine if you place them directly onto the scanner, rather than feeding them through the document feeder.

### Avoid valuable documents

Apple recommends that you avoid using the document feeder to scan valuable originals. Some important documents, certificates, and photographs fall within the acceptable limits for size and weight and can therefore go through the document feeder for scanning. You should be aware that paper jams sometimes occur, and such jams may damage a document. See “Bypassing the Document Feeder,” later in this chapter, for information about scanning without the feeder.

## Scanning with the document feeder

The document feeder significantly speeds up the scanning process, especially if you're doing optical character recognition (OCR) work. Partly because of its speed, however, the document feeder has certain limitations of which you should be aware:

- Do not scan images in color when you use the document feeder. The images you get may not meet your quality requirements.

To scan several originals using the feeder:

- 1 Lift the document feeder and make sure no originals have been left on the scanner glass.**

The document feeder will not work if an original is still on the glass.

- 2 Neatly stack the original pages *face up* on the document tray.**

You can feed up to 20 sheets of 20-lb. bond (80 g/m<sup>2</sup>) paper.

- 3 Align the bottom left corner of the stack with the appropriate paper-size mark on the document tray, as shown:**

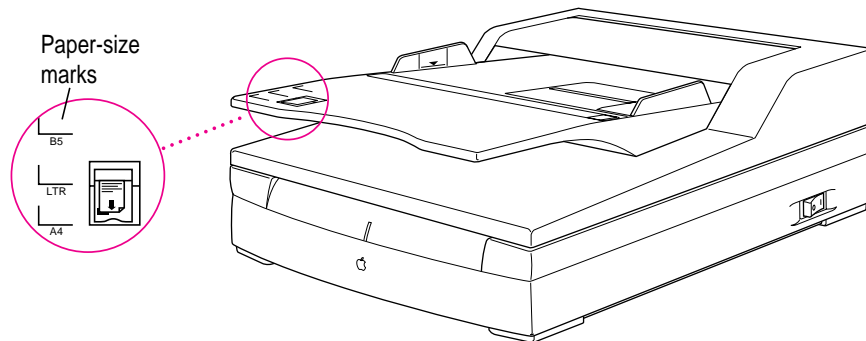

If you use legal-size paper, the ends of the sheets will extend over the end of the tray.

- 4 Gently slide the document guide in the direction of the arrow, as shown, to align the guide with the width of the originals.

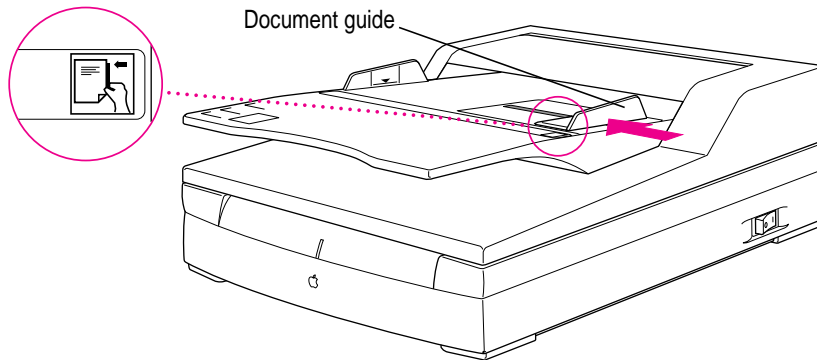

**WARNING** Do not stack the originals higher than the paper-height limit mark (5/64 in./2 mm). Do not press down on the feeder. Do not place anything heavier than 4.4 lb. (2 kg) on top of the document feeder.

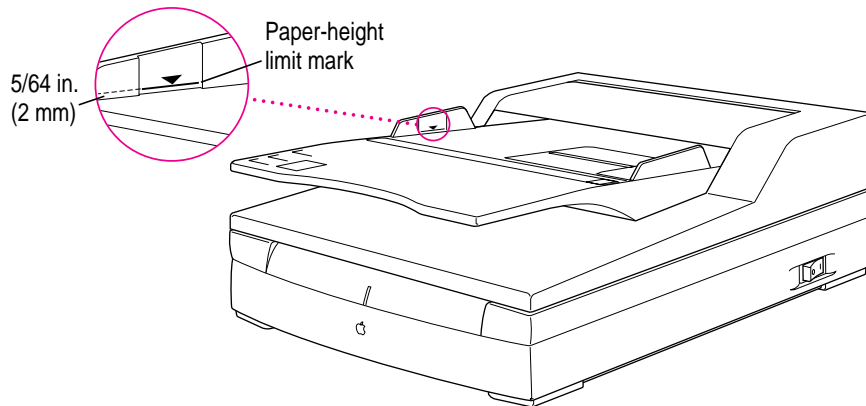

- 5 Open the OneScanner Dispatcher if necessary.

**6 Click Scan.**

The Apple Color OneScanner dialog opens.

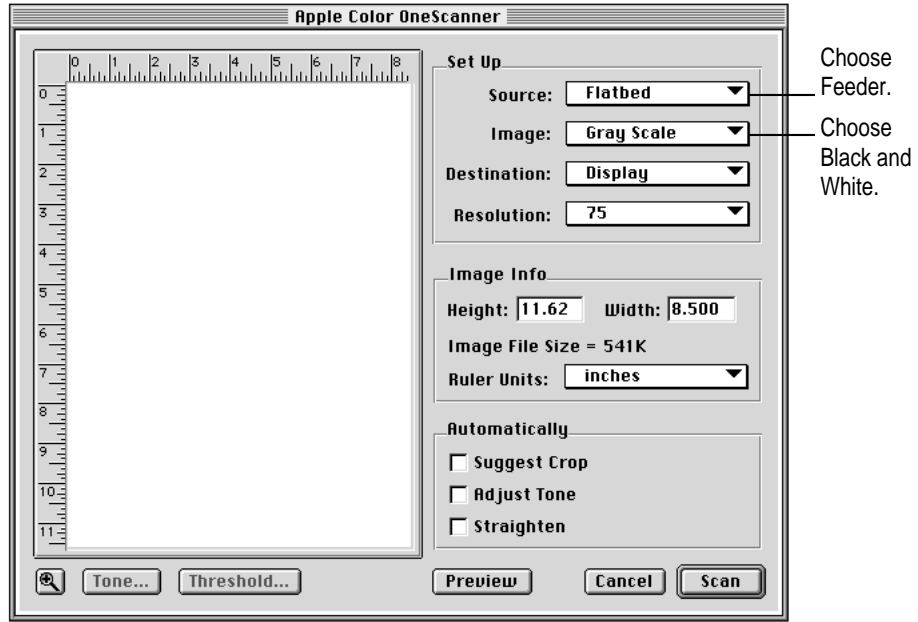

**7 From the Source pop-up menu, choose Feeder.**

**8 From the Image pop-up menu, choose Black and White.**

**9 Click Scan.**

The document feeder passes each original under the cover as it is being scanned and then deposits the original in the document exit tray. The process continues until all originals have been scanned.

If you're scanning text, you can now use the drag-and-drop icon for TextBridge to convert the scanned images to text.



## Bypassing the document feeder

As mentioned earlier in this chapter, certain originals may not work properly with the document feeder. You may want to scan valuable documents that could be damaged by the document feeder. You can do this by placing the originals on the scanner glass rather than using the document feeder.

To bypass the document feeder:

- 1 Lift the document feeder as if it were the scanner cover.

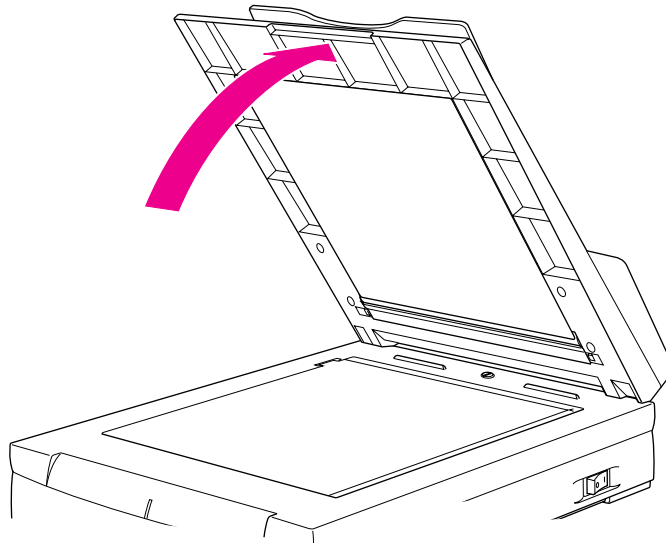

- 2 Place the original on the glass.
- 3 Lower the document feeder over the original, if possible, so the document feeder is closed during the scan.
- 4 Scan the original as usual.

## Clearing paper jams

If you scan only acceptable originals, you should have little trouble with paper jams. For a review of factors that make originals acceptable, see “Choosing Originals to Scan,” earlier in this chapter.

If a paper jam occurs while you’re using the document feeder, follow the steps given in this section to clear the jam.

### Follow the path

Clearing a paper jam is simple if you know where the jam occurs. Here is a look at the path originals take as they move through the document feeder:

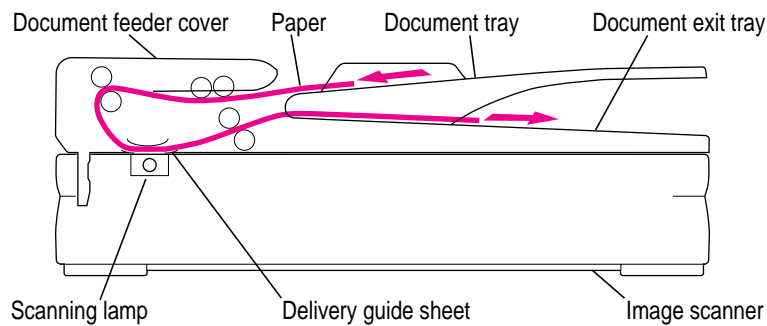

## Paper jams at the beginning of a scan

To clear a paper jam that occurs at the beginning of a scan:

- 1 **Lift the document feeder cover, as shown, and remove the jammed paper.**

First, lift the document feeder cover.

Then, carefully remove the jammed paper.

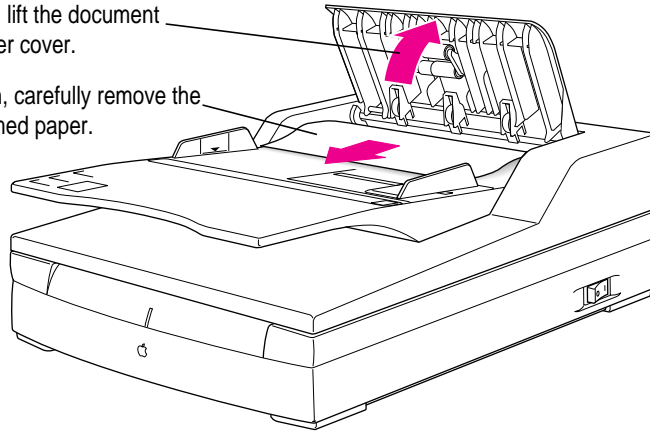

- 2 **Close the document feeder cover by placing your fingers on the center of the cover and gently pressing down until the cover locks into place.**

Document feeder cover

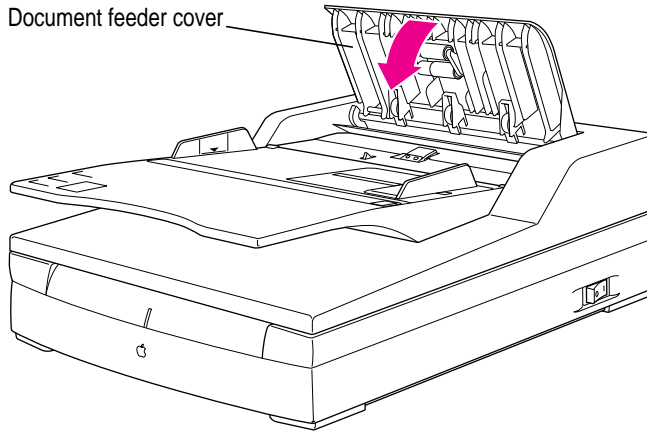

## Paper jams at the end of a scan

To clear a paper jam that occurs at the end of a scan:

- 1 Lift the document feeder cover, as shown.

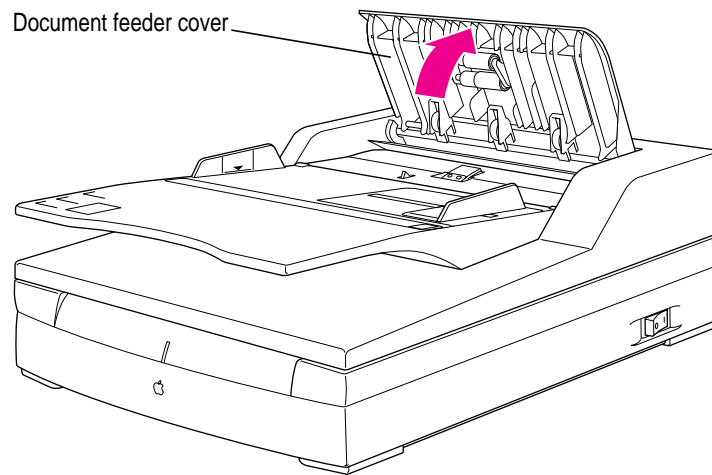

- 2 Lift the document tray and carefully remove the jammed paper, as shown.

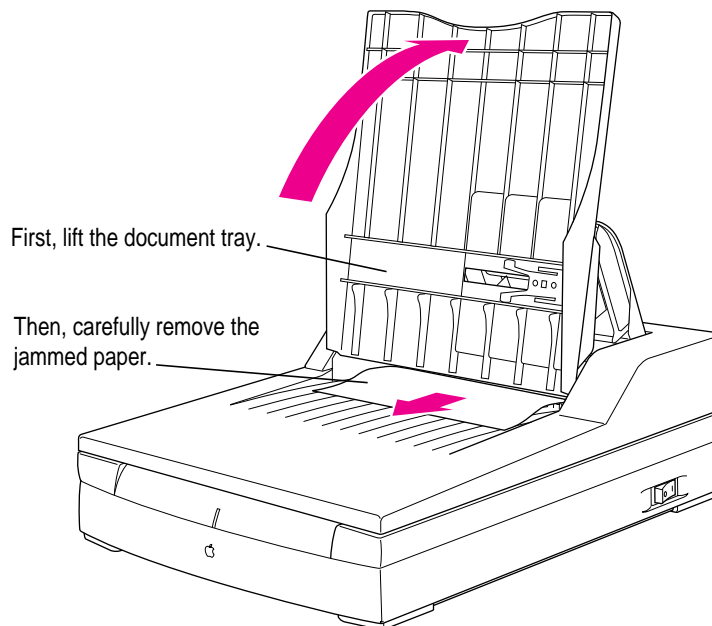

**3 Close the document tray.**

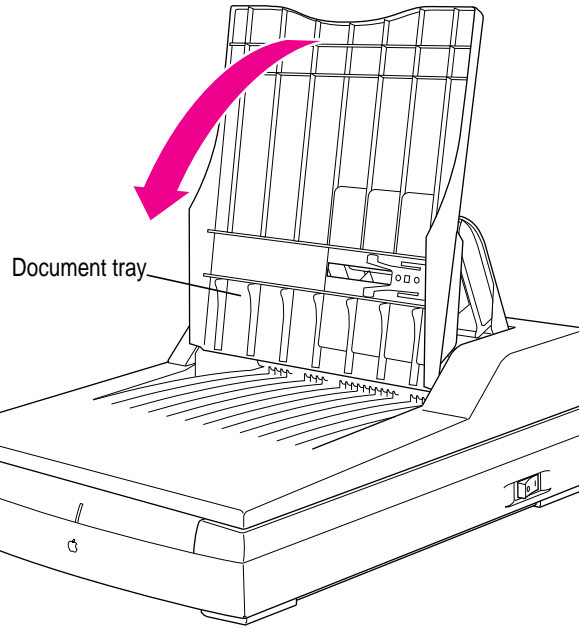

**4 Close the document feeder cover.**

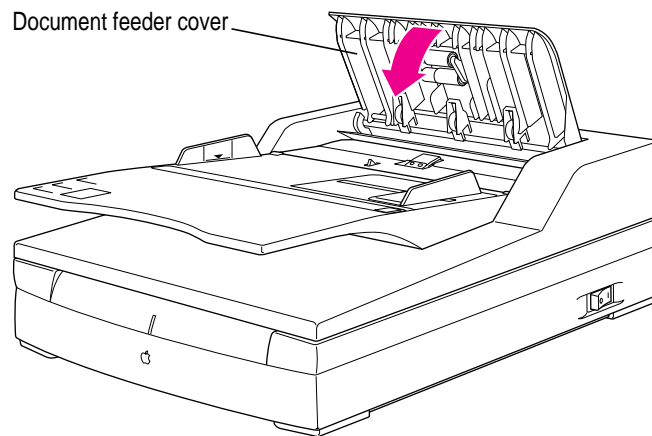

## Paper jams inside the document feeder

To clear a paper jam that occurs inside the document feeder:

- 1 Lift the document feeder cover, as shown.

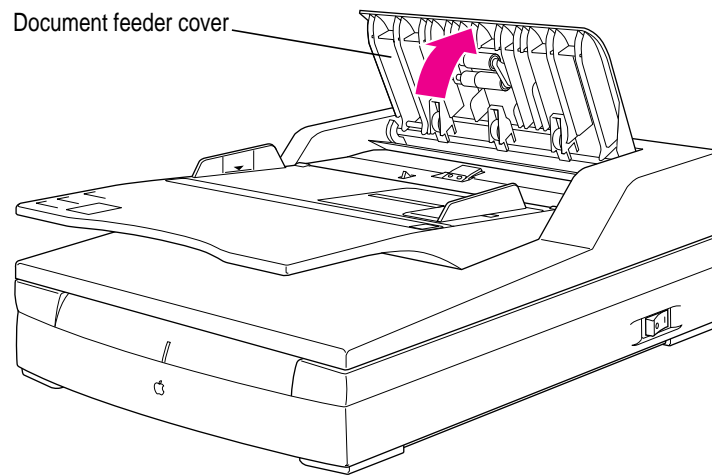

- 2 Lift the document tray to get to the jammed paper.

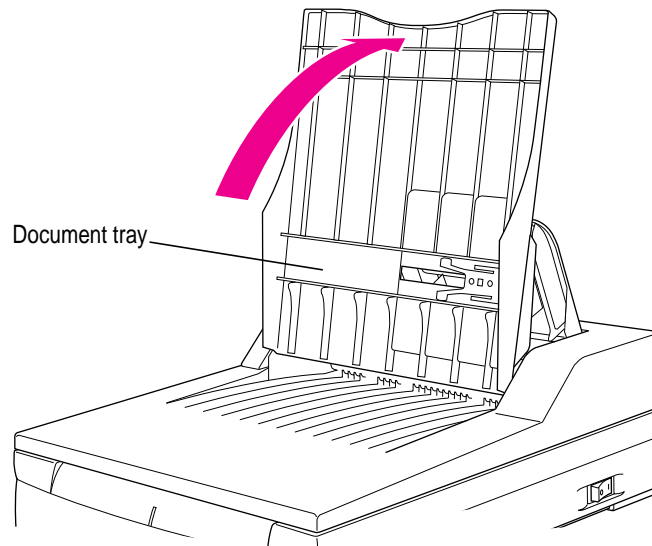

- 3** Press the two tabs (below) inward.

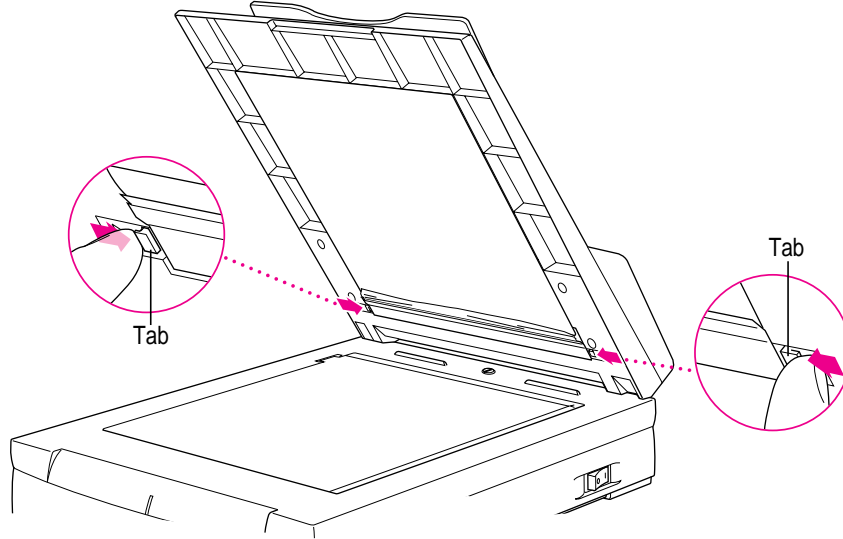

- 4** Open the flap, lower the delivery guide sheet, and carefully remove the jammed paper, as shown.

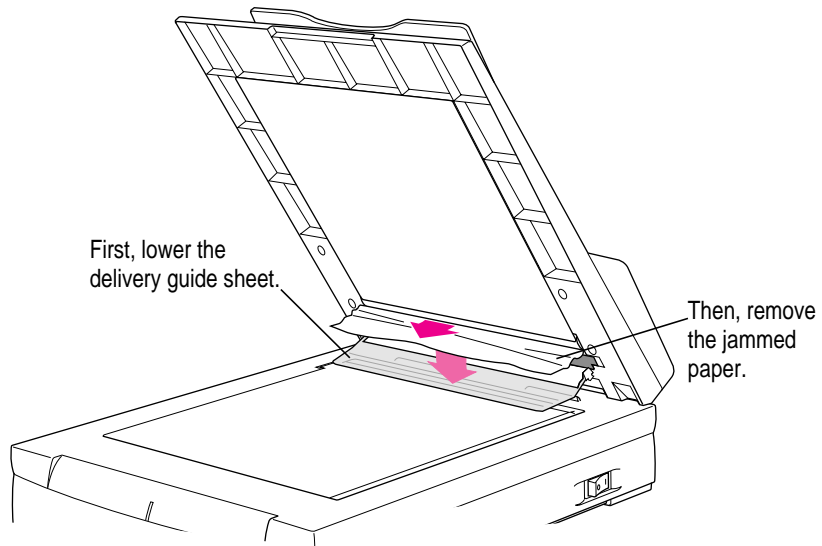

**5 Reinsert the delivery guide sheet.**

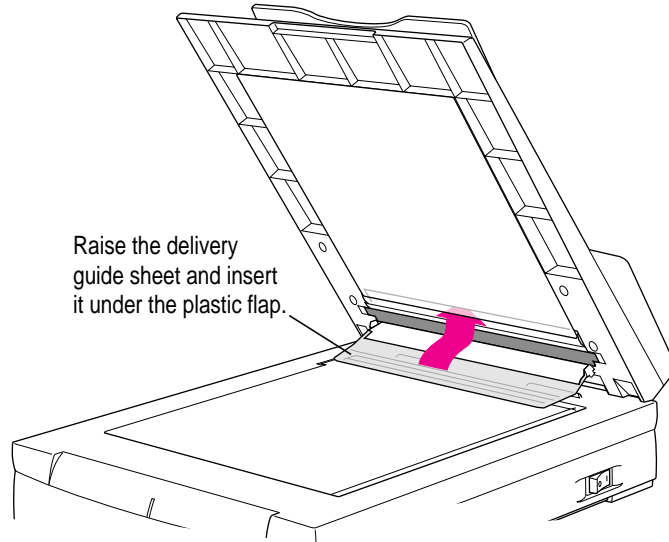

**6 Close the document feeder and feeder cover.**

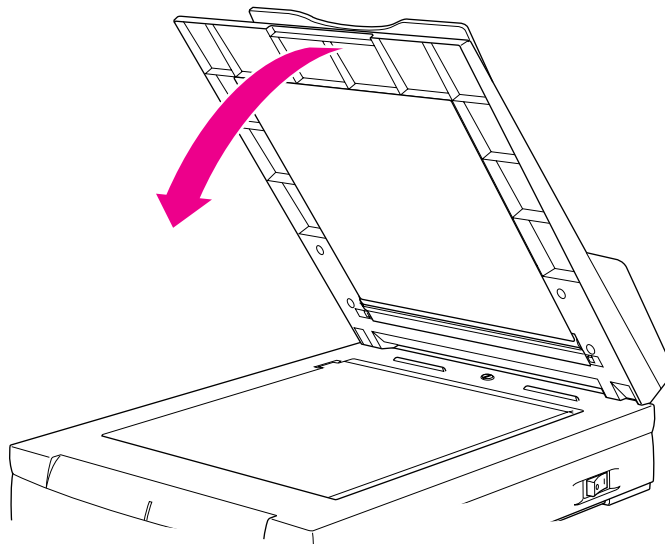



## Maintenance

With minimal maintenance, your document feeder will provide many years of service. Follow these guidelines to keep the document feeder working properly.

**WARNING** Do not attempt to service the document feeder yourself. Refer all servicing to an authorized Apple service center. For the location of the center nearest you, please call your Apple reseller.

### Cleaning the document feeder

To clean the document feeder:

- 1** If the document feeder is still attached to the scanner, turn off the scanner.
- 2** Disconnect the scanner's power cord from the wall outlet.

**WARNING** Never use a chemically treated cloth or cleaners containing alcohol, benzene, or ammonia. If you do, the outside covering can become discolored or deformed, or it may melt.

- 3** Dampen a cloth with water or a mild cleaning agent, and then thoroughly wring out the cloth.
- 4** Use the cloth to gently wipe clean the document feeder.
- 5** Dry the areas you cleaned with a clean, soft, dry cloth.
- 6** If the delivery guide sheet becomes dirty, or if vertical black lines appear on the scanned image when you use the document feeder, gently wipe clean both surfaces of the delivery guide sheet with a clean, soft, dry cloth.

For information about removing the delivery guide sheet, see the next topic.

## Removing and replacing the delivery guide sheet

Your document feeder is equipped with a replaceable delivery guide sheet. If the delivery guide sheet becomes extremely dirty or if it gets damaged, you can purchase a replacement from your authorized Apple reseller.



Delivery guide sheet

To replace the delivery guide sheet:

- 1 **Switch off the Macintosh and scanner.**
- 2 **Unplug the document feeder connector cable from the scanner.**

- 3 Remove the document feeder by grasping both sides of the document feeder cover and lifting upward, as shown.

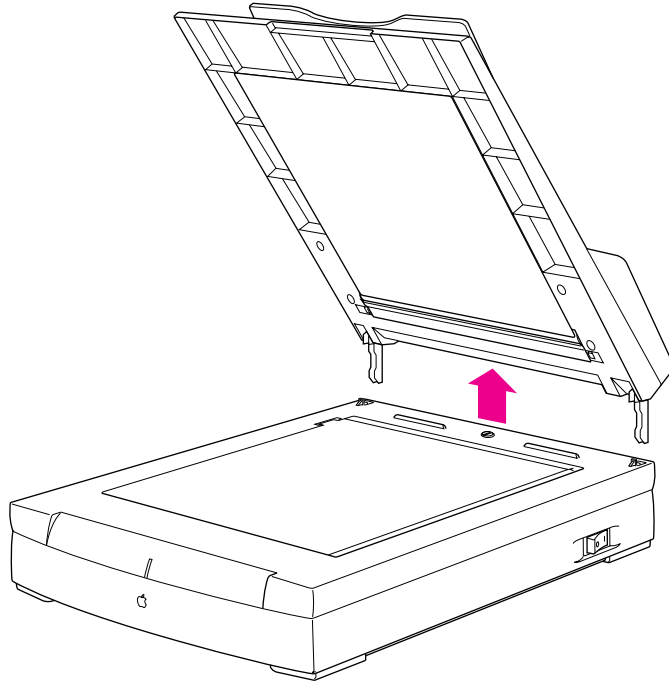

- 4 Turn the document feeder over so the bottom side—with the white plastic sheet—is facing upward.

**5 Press the two tabs inward.**

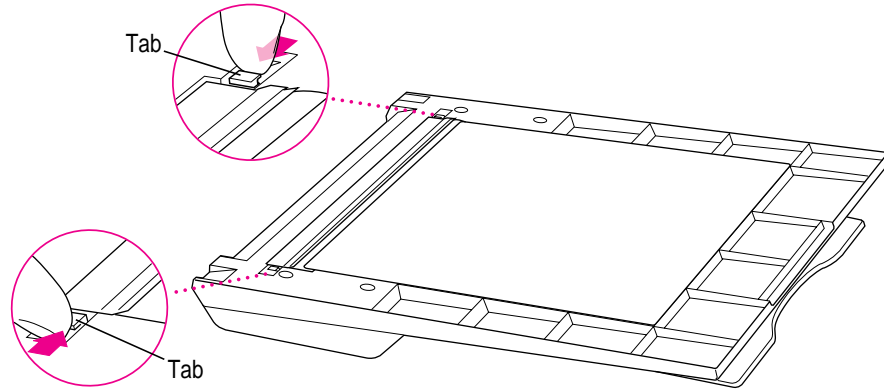

**6 Open the flap and remove the delivery guide sheet, as shown.**

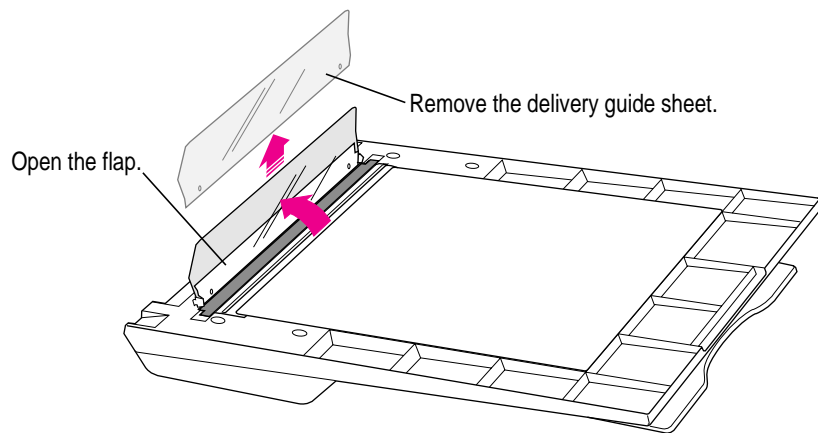

- 7** Slide the new delivery guide sheet under the document feeder casing beneath the white plastic cover.

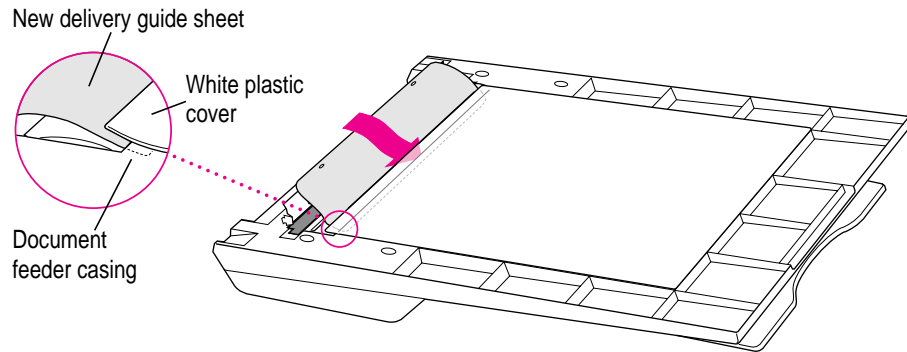

- 8** Align the two holes in the delivery guide sheet with the pegs on the flap (as shown), and close the flap.

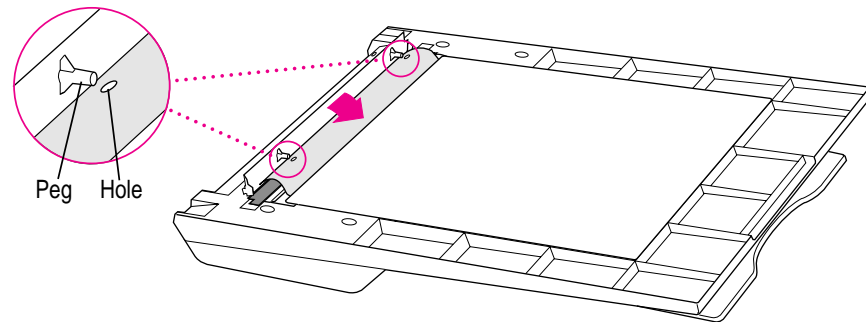

- 9** Replace the document feeder on the scanner.

## Removing and replacing the paper separator

Your document feeder is equipped with a replaceable paper separator, which causes the document feeder to feed one original at a time. If the separator repeatedly feeds more than one sheet, or fails to feed a sheet at all, you can purchase a replacement from your authorized Apple reseller.

To replace the paper separator:

- 1 **Position the document feeder so its front is facing you, and lift the document feeder cover, as shown.**

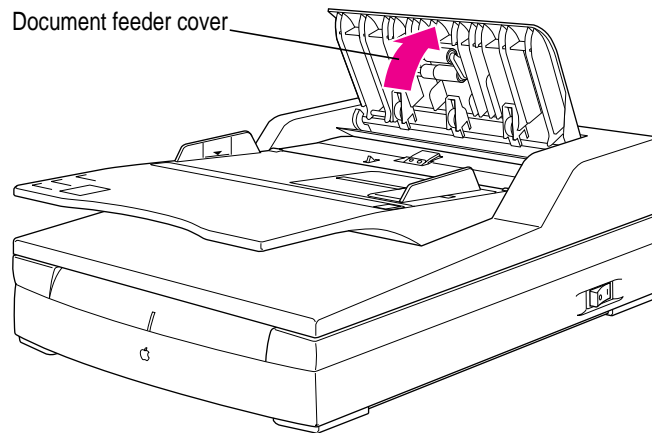

- 2 Press the separator downward to unlock it, slide the separator toward you, and then lift the separator straight up and out of the document feeder.

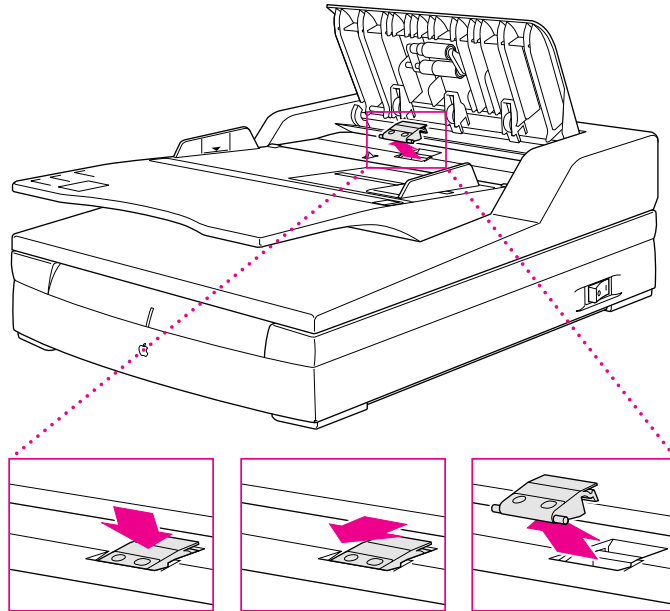

- 3** Insert the new separator, and press it downward and then away from you.

Make sure that the separator is securely in place.

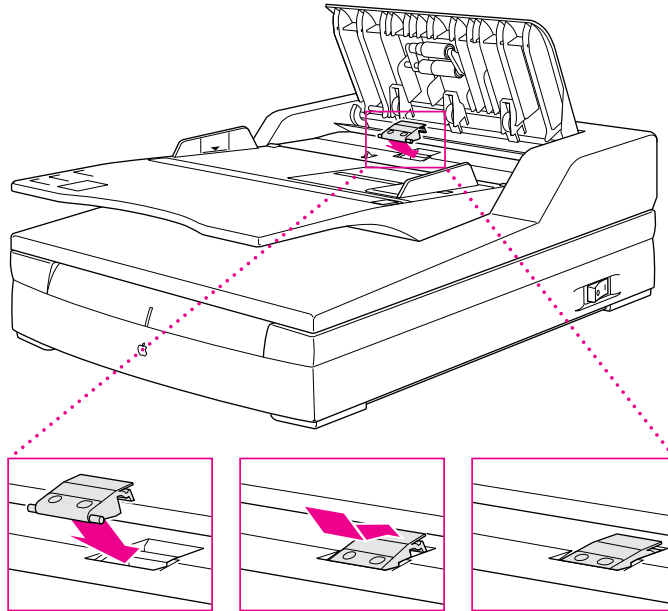

- 4** Close the document feeder cover.

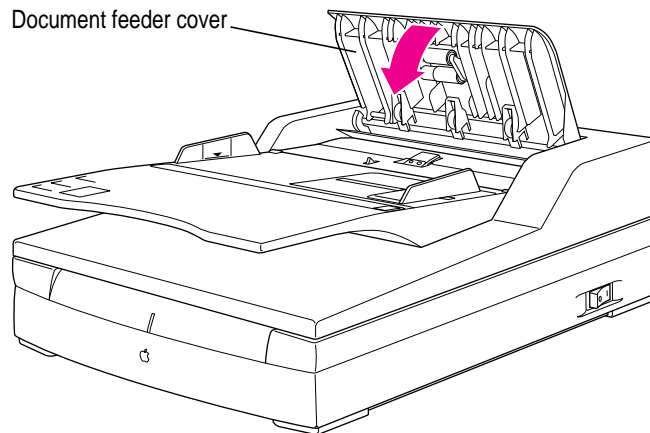



# 10

## Using the Transparent Media Adapter



The Apple Transparent Media Adapter is an optional accessory you can purchase to adapt your Apple Color OneScanner 1200/30 for overhead transparencies and positive and negative film. (The adapter does not work with the Color OneScanner 600/27.)

This chapter shows you how to set up and use the Transparent Media Adapter. You'll find instructions for

- hardware setup
- loading of transparencies or negatives
- maintenance and troubleshooting

**WARNING** Handle the Transparent Media Adapter with great care. Marks or scratches on the diffuser (the smooth surface on the underside of the adapter) may appear in images scanned with the adapter. If scratches impair image quality, the adapter must be replaced. Contact your authorized Apple dealer.

### Setting up the Transparent Media Adapter

Setting up the Transparent Media Adapter is a simple process that requires no special tools. After installation, the adapter works as the top cover of the scanner. If you find later that you don't need the adapter, you can easily remove it and replace it with the original scanner cover.

*Set up the scanner first:* Before you connect the Transparent Media Adapter to your scanner, you need to set up the Apple Color OneScanner and install the scanner software. See Chapters 2 and 3 for instructions if you haven't yet set up the scanner hardware and software.

To connect the adapter:

- 1 Switch off the scanner and then switch off your Macintosh computer.**

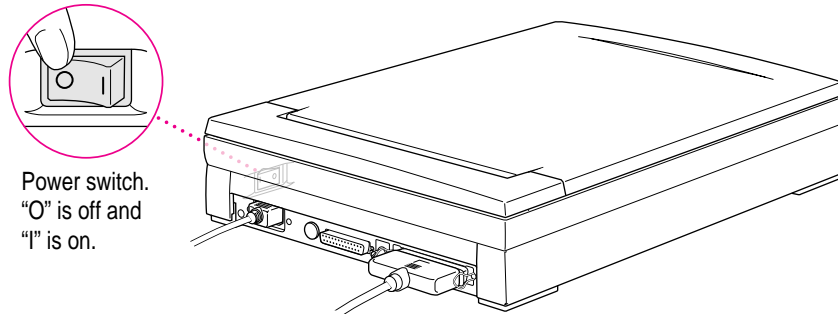

Devices connected through SCSI cables require a certain power-on and power-off sequence. See "Switching the Power On," in Chapter 2, for more information.

- 2 Grip the scanner top cover on both sides and lift it off.**

Put the original cover away in a safe place for future use. The adapter replaces the cover.

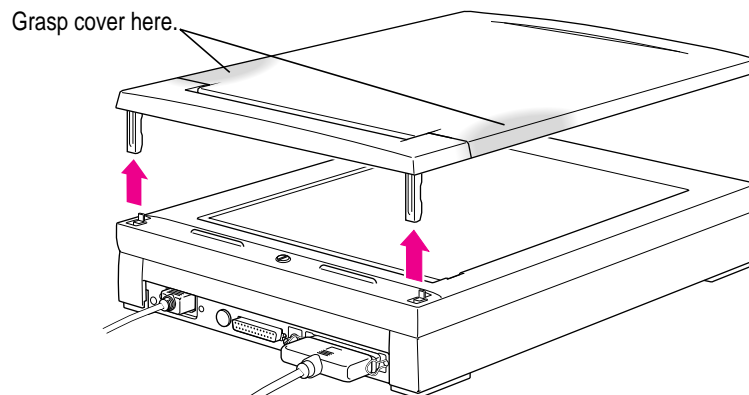

**3 Turn the Transparent Media Adapter over and unlock it.**

Press the side of the switch that shows an open lock.

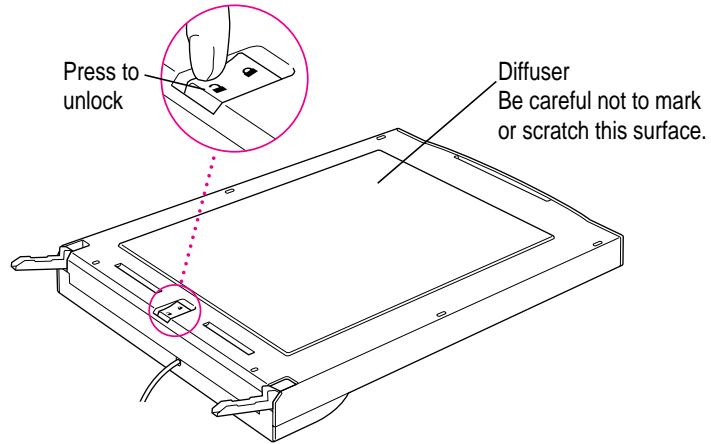

**4 Line up the transparent media alignment guide with the two holes at the back of the scanner.**

The transparent media alignment guide comes in a separate package in the box with the transparent media adapter.

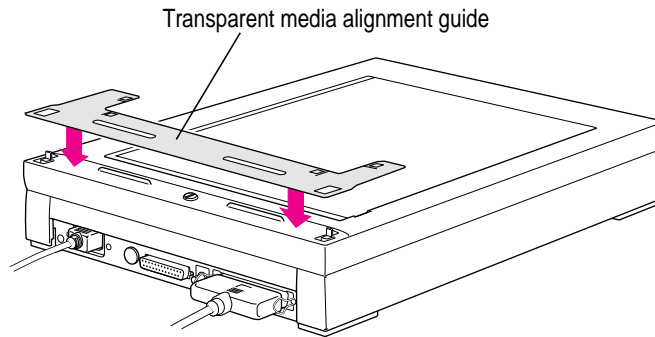

- 5** Install the metal posts through the guide and into the holes.

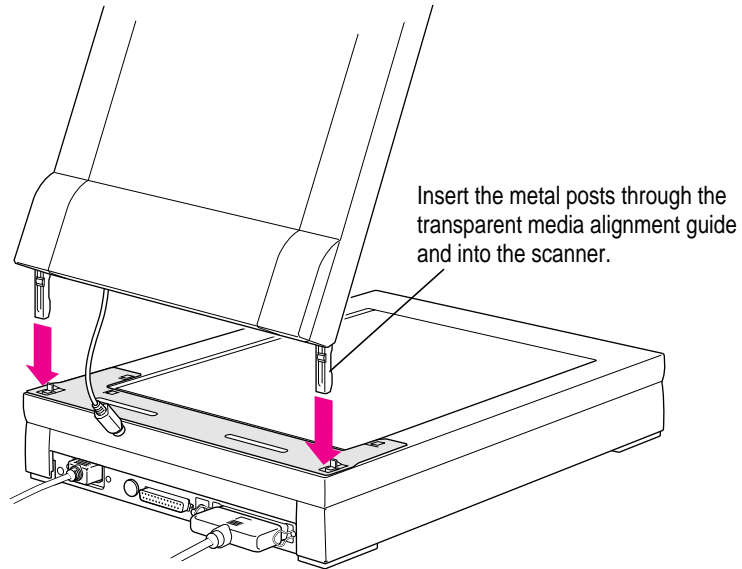

- 6** Close the adapter.

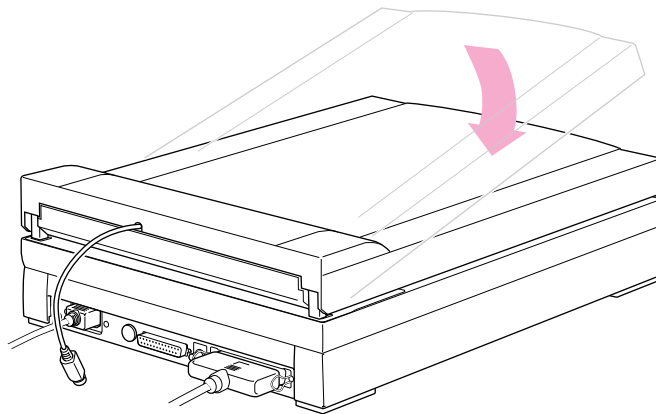

- 7 Remove the plastic cap from the port on the back of the scanner and put it in a safe place.**

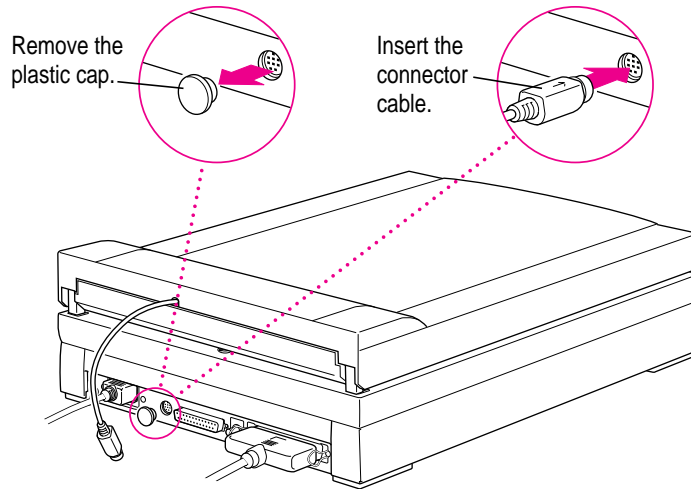

- 8 Plug the cable from the adapter firmly into the small port on the back of the scanner.**
- 9 Switch on the scanner and then switch on your Macintosh.**

The scanner may make some sounds as it calibrates and warms up. After about 20 seconds, the adapter and scanner are ready to use.

## Handling film

To protect your valuable film from fingerprints, grease, and so on, wear gloves. Most photography supply stores sell gloves designed for handling film.

## Inserting film into a film guide for scanning

The adapter comes with three film guides that can hold these sizes:

- 35-mm film
- 60-mm film
- 4 x 5-inch film

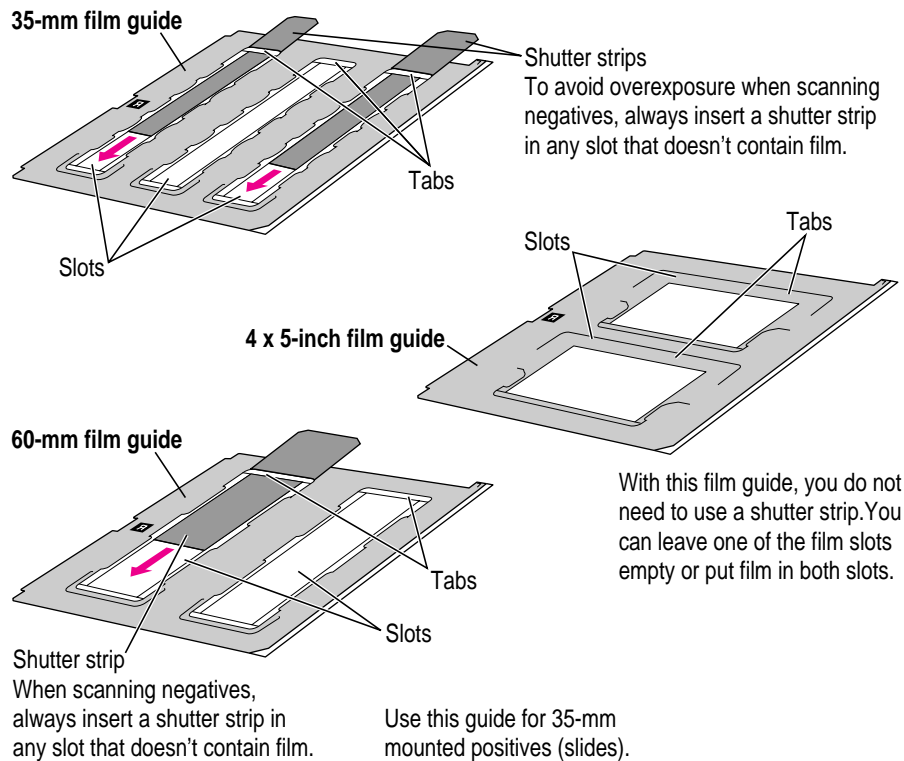

**IMPORTANT** Be sure to insert negatives into the film guide so that no light shows through at the sides of the negative film. You can allow a light gap at the top and bottom of a negative, but light that shows at the sides may cause the image to be overexposed. If you are scanning a negative that won't fit any of the film guides, create a mask for it from opaque materials to prevent light from leaking through at the sides of the negative.

To insert film into the film guide:

**1 Place the film guide on a clean, flat surface.**

Choose the guide that's appropriate for the size of film or transparency you intend to scan.

**2 Lift the tab and insert shutter strips into slots that will not have film in them.**

**IMPORTANT** Shutter strips prevent overexposure (halation) of the scanned images. If a strip of negatives is not long enough to fill the slot it's in, that is not a problem, but unused slots in the 35-mm and 60-mm film guides must contain shutter strips. (The 4 x 5-inch film guide does not require a shutter strip. You can leave one of the slots empty.) It is important not to allow any gaps at the sides of the film. Light that shows through at the sides may cause the film to be overexposed.

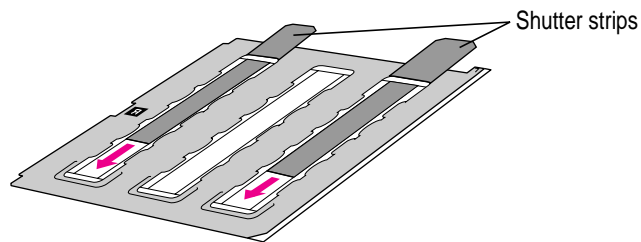

**3 Lift the tab and insert negatives or positives for scanning.**

Make sure the image is facing down. To avoid getting unwanted fingerprints on the film, wear gloves designed for handling film.

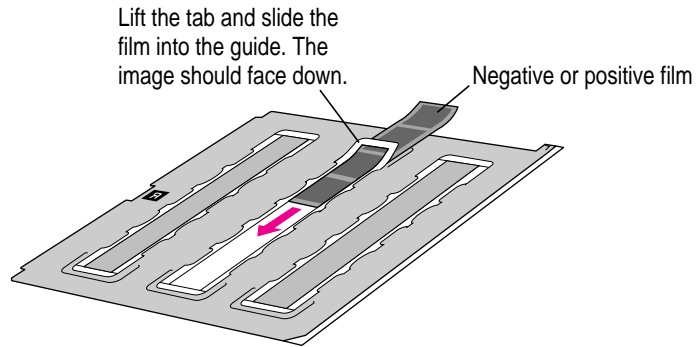

**4 Make sure the film is aligned properly in the slot.**

Hold the film guide up to a source of light to check for openings where light leaks through. The edges of the film must be parallel to the edges of the slot. If you are scanning negatives, even a small gap that allows light through perforations on the film can cause overexposure (halation) of the scanned image.



## Scanning with the Transparent Media Adapter

To scan with the adapter:

- 1 Lift the adapter and make sure no originals have been left on the scanner glass.

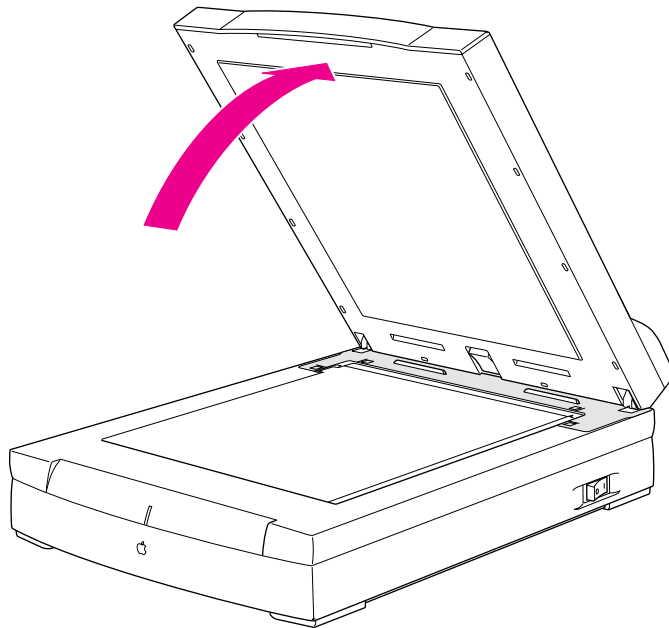

**2 Place the film guide (with film and shutters in place) on the scanner bed.**

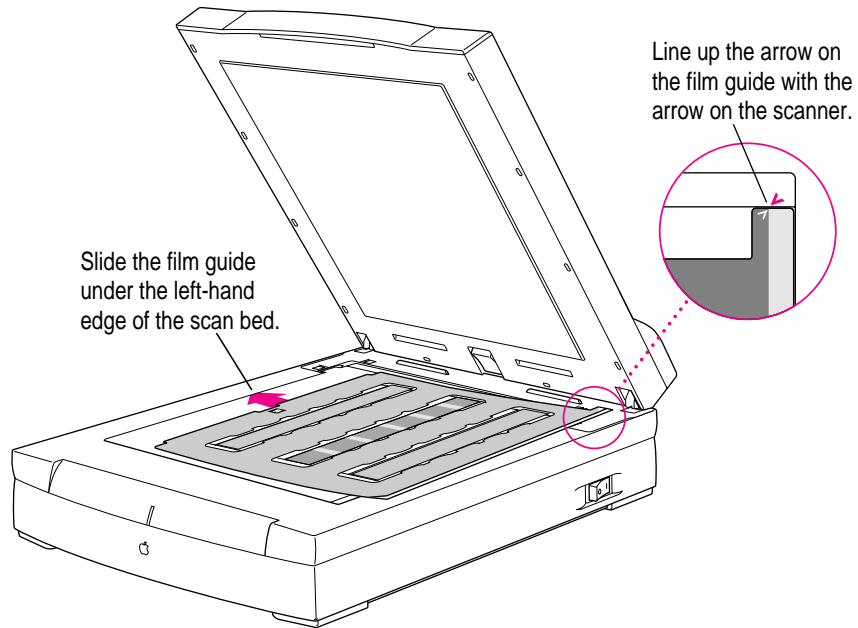

Be careful not to obstruct the light correction zone (the gap between the top of the film guide and the transparent media alignment guide).

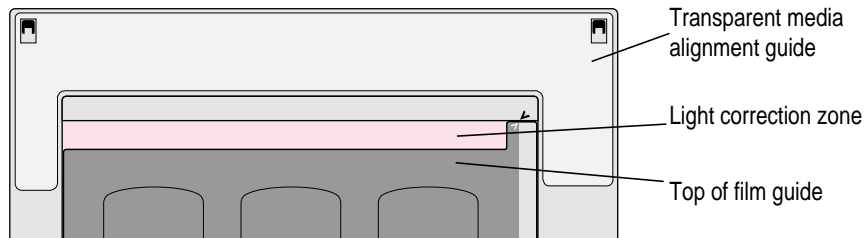

*Note:* To scan positive film that is too large for any of the film guides, place the film on the document glass, leaving space for the light correction zone. To scan negative film, create a mask from opaque material to prevent light leaks.

**3 Close the Transparent Media Adapter.**

You are ready to scan your image.

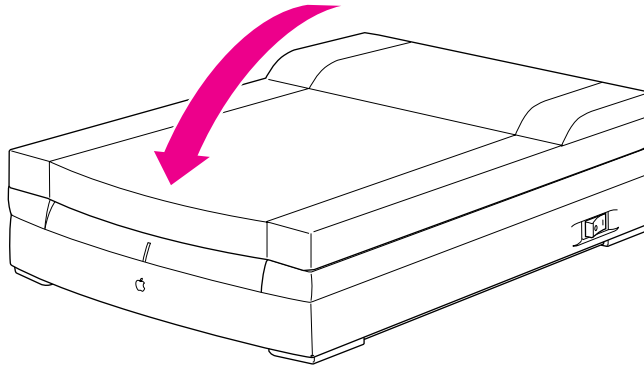

**4 If necessary, open the OneScanner Dispatcher.**

**5 Click Scan.**

The Apple Color OneScanner dialog box opens.

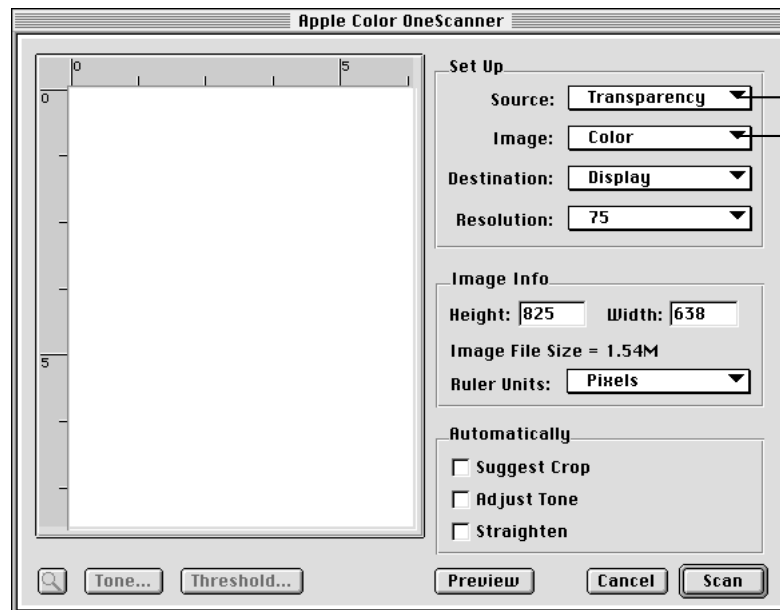

Choose Transparency.  
Choose the appropriate setting.



- 6 From the Source pop-up menu, choose Transparency.
- 7 In the dialog box that appears, select the type of film you are scanning.

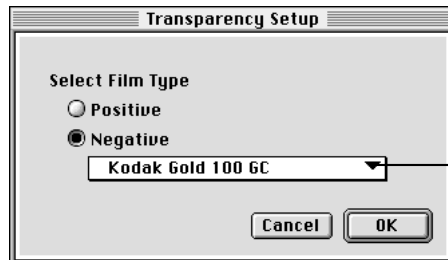

Choose the negative film you're using from this pop-up menu. (If you choose Positive, the pop-up menu is dimmed.)

Each film type named in the Negative pop-up menu belongs to one of four negative film bases. If you don't see your film named in the menu, try each of the four bases for scanning your negative. Then use the one you like best. The bases to try are:

- Agfa Optima 400
- Agfa XRS
- Kodak Ektapress
- Kodak Ektar

- 8 Click OK.
- 9 Click Scan.

The scanner scans the film. If you are scanning negatives, the scanner takes extra time for calibration.

## Bypassing the adapter

Even though you have the Transparent Media Adapter on your scanner, you can still scan paper originals. Place the originals on the document glass. In the Dispatcher window, choose Flatbed from the Source pop-up menu. Then preview or scan as usual. Be careful not to scratch the diffuser with staples or paper clips attached to paper originals. Scratches are permanent and may show up as flaws in the images you scan from film.

## Maintenance

With minimal maintenance, your adapter will provide many years of service. Follow these guidelines to keep the adapter working properly.

**WARNING** Do not attempt to service the adapter yourself. Refer all servicing to an authorized Apple service center. For the location of the center nearest you, please call your Apple reseller.

### Cleaning the exterior of the adapter

To clean the adapter:

- 1 If the adapter is still attached to the scanner, turn off the scanner.
- 2 Disconnect the scanner's power cord from the wall outlet.

**WARNING** Never use a chemically treated cloth or cleaners containing alcohol, benzene, or ammonia. If you do, the outside covering can become discolored or deformed, or it may melt.

- 3 Dampen a cloth with water or a mild cleaning agent, and then thoroughly wring out the cloth.
- 4 Use the cloth to gently wipe clean the adapter.
- 5 Dry the areas you cleaned with a clean, soft, dry cloth.

## Cleaning the diffuser

The diffuser is the inside surface of the adapter through which light is transmitted. Dirt or scratches on its surface may discolor or distort scanned images.

To clean the diffuser:

- 1 **Open the adapter and let its hinges hold it open.**
- 2 **Lightly wipe the dirt off the diffuser with a dry, soft cloth.**

**WARNING** Do not press or rub hard as you wipe the diffuser. This might scratch the surface. Never use a chemically treated cloth or cleaners containing alcohol, benzene, or ammonia. If you do, the surface of the diffuser may be discolored, deformed, or even dissolve.

## Troubleshooting

### The lamp doesn't light, or it lights but doesn't move.

- The cable from the adapter may not be properly plugged into the port on the back of the scanner.

Make sure the cable is plugged in firmly.

- The light correction zone may be blocked.

Be sure to leave an unobstructed .59-inch (15-mm) space at the top of the document glass. For more information about the light correction zone, see “Scanning With the Transparent Media Adapter,” earlier in this chapter.

### The quality of the scanned image is poor.

- The film may not be positioned correctly.

Load the film into a film guide. Make sure the film is straight in the slot. Make sure the lid is closed.

**The image is reversed.**

- The film is facing the wrong way.  
Make sure the film is face down.

**Color quality is unsatisfactory.**

- All or part of the light correction zone has been obstructed.

If the film is in a film guide, make sure the guide is positioned properly. See “Inserting Film Into a Film Guide for Scanning,” earlier in this chapter.

If you’re not using a film guide for positives, be sure to allow at least .59 inch (15-mm) of space between the top edge of the film and the top edge of the document glass. (The space comprises the necessary light correction zone.)

If you’re not using a film guide for negatives, be sure to allow space for the light correction zone. In addition, be sure to mask the sides of your negatives to avoid overexposure (halation). Use a black opaque material for masking (something similar to the material in the film guides).

- You may have selected an inappropriate negative film type, producing incorrect colors.

Choose the correct film type. For details, see “Scanning With the Adapter,” earlier in this chapter.

- You may not have selected an appropriate ColorSync profile for the medium you are scanning.

- Color OneScanner Flatbed for magazines, paper, other opaque originals
- Color OneScanner Positive for positive transparencies
- Color OneScanner Negative for negatives

Every time you change from one medium to another, you must select the correct ColorSync profile. Choose ColorSync Preferences from the Image menu. In the dialog box that appears, select the profile you want.

**An irregular blotch or line consistently appears in the same place in scanned images.**

- The diffuser may be dirty.  
Carefully wipe the diffuser with a clean, soft, dry cloth. See “Maintenance,” earlier in this chapter.
- There may be a scratch or other mark on the diffuser.  
Contact an authorized Apple service center. For the location of the center nearest you, please call your Apple reseller.
- The film or transparency may be dirty.  
Carefully wipe the film with a clean, soft, dry cloth.
- There may be a scratch or other mark on the film or transparency.  
Replace the film with a copy that has not been scratched or marked.

**The edge of an image is dark.**

- The adapter may not be securely shut.  
Make sure the adapter is closed before you scan.

**Scanned images from negatives contain faded or whitened areas.**

- Gaps around the edge of the negative film can allow overexposure (halation) to occur.  
Make sure the film and the shutter strips are correctly positioned in the film guide. For details, see “Inserting Film Into a Film Guide for Scanning,” earlier in this chapter. If necessary, you can use black paper (or any opaque paper) to mask the gaps.

**You see a striped or moiré pattern on a scanned image.**

- Moisture on the film or the document glass causes the film to stick to the glass.  
Use a soft, clean, dry cloth to wipe the moisture (or oil) from the diffuser, the film, or the document glass.





## Appendix A Technical Specifications

.....

### Physical

- Length 16 in. (406 mm)
- Width 11-1/8 in. (283 mm)
- Height 3-1/8 in. (79 mm)
- Weight About 13.2 lb. (6 kg)

### Technical

- Scanner type Flatbed
- Scanning element Charge-coupled device (CCD) image sensor
- Resolution 60 to 2400 dpi (Apple Color OneScanner 600/27)  
60 to 4800 dpi (Apple Color OneScanner 1200/30)
- Bit depth 27 (Apple Color OneScanner 600/27) 9, 9, 9 is RGB  
30 (Apple Color OneScanner 1200/30) 10, 10, 10 is RGB
- Maximum document size 8.5 by 11.7 in. (216 by 297 mm)  
8.5 by 14 in. (216 by 355.6 mm) with optional Automatic Document Feeder  
8 by 10.8 in. (203.2 by 274 mm) with optional Transparent Media Adapter
- Interface SCSI II

- Other functions      RGB masking (color only)  
Window (scan area) selection, negative/positive reversal, X–Y scaling, mirror image
- Options              Automatic Document Feeder  
Transparent Media Adapter

## Environmental

### Noise (maximum)

- Scanning              <55 dB

### Operating temperature

- *Without the document feeder, with or without the Transparent Media Adapter*  
Ambient temperature: 41 to 95° F (5 to 35° C)  
Relative humidity: 15 to 85 percent
- *With the document feeder*  
Ambient temperature: 50 to 90.5° F (10 to 32.5° C)  
Relative humidity: 20 to 80 percent

## Power requirements

- Power supply        AC input: 100-240 V  
                             +/- 10 percent, 48 to 62 H
- Power consumption 35 W maximum



## Appendix B Troubleshooting



In general, as long as you follow the maintenance and safety instructions provided in this manual, you should have few problems with your scanner. This chapter provides solutions to some problems that you might encounter.

**IMPORTANT** If you have a problem with your scanner and nothing recommended here solves it, contact your authorized Apple service center.

*Note:* If you have the optional Transparent Media Adapter on your scanner, you should also see the troubleshooting section in Chapter 10.

### Scanning and hardware problems

**The scanner icon has an “X” across it when I start up my Macintosh.**

- The scanner may be off.

Make sure the scanner is plugged in and that the power light is on.

- You may have turned on the power in the wrong sequence.

Always switch on the scanner before you switch on the Macintosh. Shut down the Macintosh, switch the scanner on, wait about 20 seconds, and restart the Macintosh.

- The SCSI ID number or termination may be incorrectly set.

Check the setting for the SCSI switch on the back of the scanner. For information, see Chapter 2, “Setting Up the Scanner.”

- The SCSI connection may not be secure.

Make sure the SCSI cable between the scanner and the Macintosh is securely fastened. If the scanner is part of a SCSI chain, check all the SCSI cables.

**When I try to scan, I get a message that says, “The application can’t find the scanner.”**

- You may not have properly installed the scanner software.  
Review Chapter 3, “Installing the Scanner Software,” and then reinstall the software.
- You might have a conflict between the Apple Color OneScanner driver and another system extension.  
See your Macintosh user’s manual or Macintosh Guide, Apple’s online help system, for information about resolving system conflicts.
- The scanner may not be on.  
Check the power light. If it’s off, shut down the Macintosh, switch the scanner on, and then restart the Macintosh.
- The SCSI ID number or termination may be incorrectly set.  
Check the setting for the SCSI switch on the back of the scanner. See Chapter 2, “Setting Up the Scanner.”

**Everything on my monitor screen is frozen.**

- Your system is hung.  
Turn the scanner off, wait ten seconds, and turn it on again. Then restart your Macintosh.

**When I switch the scanner on, its power light goes on briefly and then goes off.**

- The power cord may be loose.  
Make sure the power cord is securely inserted in a grounded three-pin power outlet. If plugging the cord in doesn’t solve the problem, you may have a serious hardware problem. See your authorized Apple service center.



**The scanner makes strange noises when I try to scan, and no image is produced.**

- The scanner carriage may be locked.

Make sure the scanner lock is in the unlocked position. For information, see “Locking and Unlocking the Scanner” in Chapter 2.

**I still have my old Apple OneScanner attached to my Macintosh. When I try to scan with the OneScanner Dispatcher application, a message tells me the application can’t find the new scanner.**

- You may need to reset the SCSI ID number for the new scanner.

Assign a SCSI ID number to the new scanner that is lower than the ID number assigned to the old scanner. For information, see Chapter 2, “Setting Up the Scanner.”

Or, turn off the old scanner or remove it from the SCSI chain.

**Something inside the scanner rattles when I move the scanner.**

- The scanner’s internal hardware may have been damaged.

You may have a serious hardware problem. See your authorized Apple service center.

**I keep getting messages that there’s not enough space on my hard disk.**

- You may need a larger hard disk.

Try these memory-saving options:

- Try scanning at a lower resolution so less space is needed.
- Try cropping the image before you scan. A smaller image requires less space.
- Try switching to Black and White or Grayscale when you scan. Images scanned with these options require less space than images scanned in color.

## Image quality problems

**My images have smudges and smears all over them.**

- The scanner glass and the scanner cover may need cleaning.  
Use a clean, soft, damp cloth to wipe the glass and cover clean.

**Scanned images have consistent vertical streaks through them, even though I've cleaned the scanner glass.**

- You may have a hardware problem.  
See your authorized Apple service center.

**My scanned images are of generally poor quality.**

- You may be letting too much light in.  
Make sure the scanner cover is closed when you scan.

## Problems with the Automatic Document Feeder

**When I try to use the Automatic Document Feeder, the Feeder command in the Source pop-up menu is dimmed and unavailable.**

- The small cable that connects the document feeder to the scanner may have come loose.  
Switch off the scanner and your Macintosh and connect the cable. Switch the scanner on again, wait about 20 seconds, and then switch on your Macintosh.

**My Automatic Document Feeder is not feeding originals when I try to scan them.**

- You may not have set the software source correctly.  
Make sure you've selected Feeder in the Source pop-up menu of the Apple Color OneScanner dialog box.
- The document feeder may not be able to find the originals.  
Make sure you've placed the originals in the input tray.

**I get a message that says the computer can't see the document feeder.**

- You may not have set the software source correctly.  
Make sure you've selected Feeder in the Source pop-up menu of the Apple Color OneScanner dialog box.



## Appendix C Assembling a SCSI Chain



This appendix shows you how to connect a chain of devices to your Macintosh computer.

**IMPORTANT** If the scanner is the only SCSI device you plan to connect to your computer, do not use the instructions in this appendix. Instead, see Chapter 2, “Setting Up the Scanner,” where you’ll find the information you need.

### About SCSI ID numbers

Your Macintosh has an *external* SCSI port that accepts a SCSI cable. You use this port to connect a device, such as the scanner.

Your computer may also have a second, *internal* SCSI connection. The computer’s internal hard disk drive is connected to this. If your computer came with a CD-ROM drive, the drive is also attached to the internal SCSI interface.

### Each device has a unique ID number

To keep everything straight, the Macintosh requires that each SCSI device be assigned a SCSI ID number. This SCSI ID number is

- set by a hardware switch in each device
- tracked by the system software

For example, the internal hard disk drive is, by convention, always assigned SCSI ID 0 (internal). The system software shows the hard disk at that location.

You can connect a total of seven internal and external SCSI devices to the Macintosh. Each device must have its own unique SCSI ID number, from 0 to 6 (or from 1 to 6 if you have an internal hard disk drive installed).

*About ID numbers:* Do not assign numbers 0 or 7 to the scanner. The default setting for the internal hard disk drive is 0, and for the computer, 7. Make sure you use a number that is not assigned to any other SCSI device because each ID number must be unique.

### Factory setting

The SCSI ID number for the Apple Color OneScanner is set in the factory at 2, with termination on (see the next section), but you can change the setting if necessary.

## About SCSI termination

To ensure accurate transmission of information, a terminator is used at the end of a SCSI chain, even if there is only one device in the chain.

Any Macintosh computer with an internal hard disk drive contains its own terminator. This means that you need only one other terminator (internal or external) attached to the last device in the chain.

The Apple Color OneScanner has an internal (built-in) terminator. This control switch can be set to various SCSI ID numbers. Each number can be set with termination on or off.

- With termination on, information stops at the scanner.
- With termination off, information can pass through the scanner and travel onward down a chain to another SCSI device.



## Factory setting

The internal terminator for the Apple Color OneScanner is set to “on,” but you can change it.

*Note:* You need an external terminator with the scanner only if you have a Macintosh IIx or PowerBook computer. The Macintosh IIx requires a special terminator. Make sure you purchase the appropriate item if you need an external SCSI terminator.

## Connecting the SCSI devices

The illustrations later in this appendix show various SCSI arrangements and show where termination is required. Use the illustrations for reference as you set up a SCSI chain.

To connect your SCSI devices to your Macintosh computer:

- 1 **Turn off the computer and any SCSI devices, but leave the power cords plugged into grounded outlets.**

**WARNING** Make sure your computer and all SCSI devices are turned off. If either the computer or any of the devices remains on, you could damage the computer or the device.

- 2 **Touch any of the metal connectors on the back of your Macintosh.**

This safely discharges static electricity that may be on your clothes or body.

- 3 **Attach the small end of the system cable to the SCSI port on the Macintosh.**
- 4 **Attach the large end of the system cable to either SCSI port on the back of one of the devices in your SCSI chain.**

- 5 Attach either end of a SCSI peripheral cable to the other port on the back of the first device.**

If you want the second device to be more than 18 inches away from the first, connect a cable extender to the end of the SCSI peripheral cable. You can use up to 20 feet (6.1 meters) of cables.

- 6 Attach the other end of the SCSI peripheral cable (or the other end of the cable extender) to either SCSI port on the back of the second device.**
- 7 Repeat steps 5 and 6 for each additional SCSI device you want to connect.**
- 8 Attach the cable terminator (if you need one) to the remaining SCSI port on the back of the last SCSI device in your chain.**

**IMPORTANT** Most external SCSI devices from Apple do not have internal terminators, but the Apple Color OneScanner has a built-in terminator. To make certain about other devices, check their manuals.

## Assembling the SCSI chain

The illustrations on the next few pages show the various SCSI configurations and the cables and termination settings required.

## Scanner is the only device connected to the Macintosh

The scanner is connected directly to the Macintosh.  
No other external SCSI devices are set up.

### All Macintosh computers *except* Macintosh IIcx and PowerBook

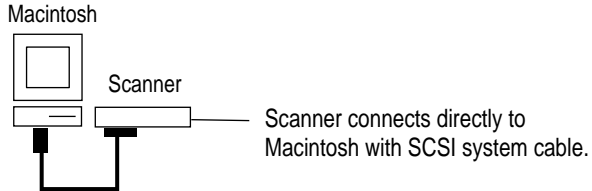

#### Scanner Termination

- No external SCSI terminator is needed.
- Use factory setting (SCSI ID number 2, termination on); no change is required.
- You can change the scanner ID number if you need to, but set termination on.

### Macintosh IIcx only

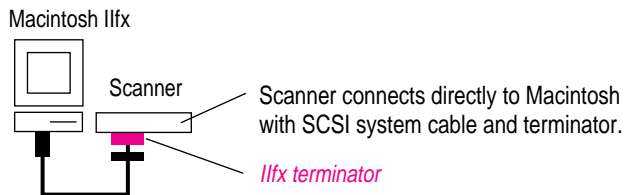

#### Scanner Termination

- Use special Apple Macintosh IIcx terminator between large end of system cable and scanner.
- Set scanner SCSI ID to number 2, termination off.
- You can change the scanner ID number if you need to, but set termination off.

### Macintosh PowerBook only

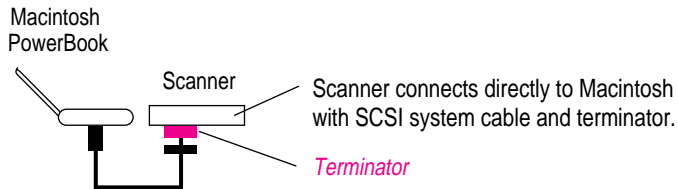

#### Scanner Termination

- Use external terminator between large end of system cable and scanner.
- Set scanner SCSI ID to number 2, termination on.
- You can change the scanner ID number if you need to, but set termination on.

## Scanner is at the end of the SCSI chain

The scanner is at the outside end of a SCSI chain.

Other external SCSI devices are set up between the scanner and the Macintosh.

### All Macintosh computers except Macintosh IIx and PowerBook

Macintosh

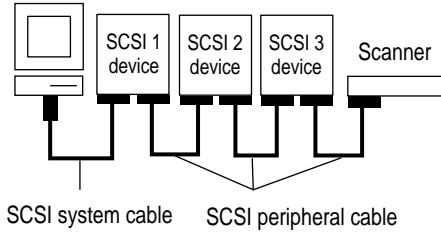

### Scanner Termination

- No external SCSI terminator is needed.
- Use factory setting (SCSI ID number 2, termination on); no change is required.
- You can change the scanner ID number if you need to, but leave termination on.

### Macintosh IIx only

Macintosh IIx

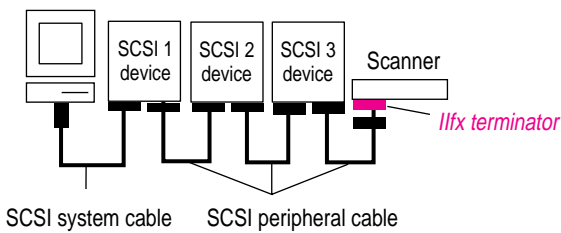

### Scanner Termination

- Use special Apple Macintosh IIx terminator.
- Use factory setting (SCSI ID number 2, termination off); no change is required.
- You can change the scanner ID number if you need to, but turn termination off.

### Macintosh PowerBook only

Macintosh  
PowerBook

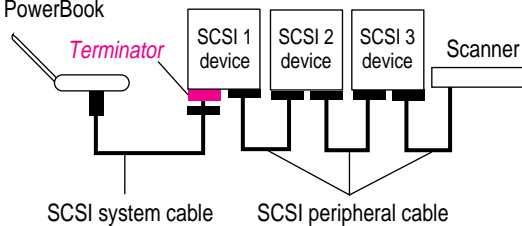

### Scanner Termination

- Use external terminator.
- Use factory setting (SCSI ID number 2, termination on); no change is required.
- You can change the scanner ID number if you need to, but leave termination on.

## Scanner is at the beginning of the SCSI chain

The scanner is connected directly to the Macintosh.  
Other external SCSI devices are set up beyond the scanner.

### All Macintosh computers *except* Macintosh IIx and PowerBook

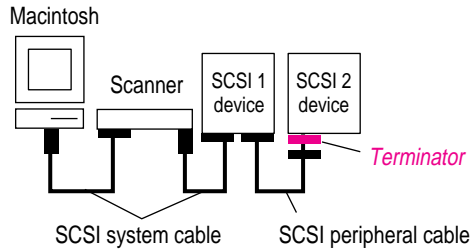

### Scanner Termination

- A SCSI terminator is needed on last device in chain.
- Set scanner SCSI ID to number 2, termination off.
- You can change the scanner ID number if you need to, but set termination off.

### Macintosh IIx only

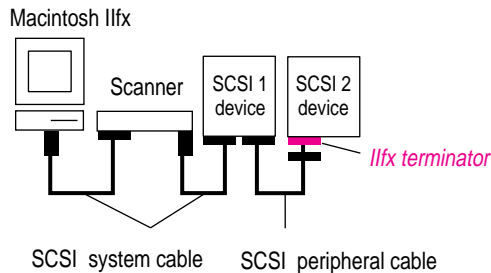

### Scanner Termination

- Use special Apple Macintosh IIx terminator on last device in chain.
- Set scanner SCSI ID to number 2, termination off.
- You can change the scanner ID number if you need to, but set termination off.

### Macintosh PowerBook only

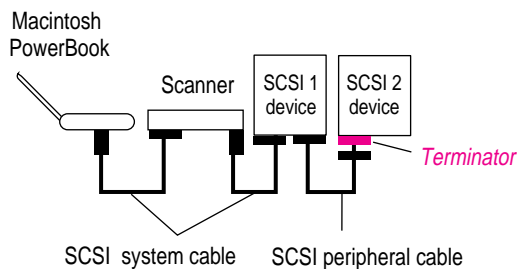

### Scanner Termination

- No external terminator needed for scanner.
- Set scanner SCSI ID to number 2, termination on.
- You can change the scanner ID number if you need to, but set termination on.

## Scanner is in the middle of the SCSI chain

The scanner is in the middle of a SCSI chain.  
The scanner is between two other external SCSI devices.

### All Macintosh computers *except* Macintosh IIx and PowerBook

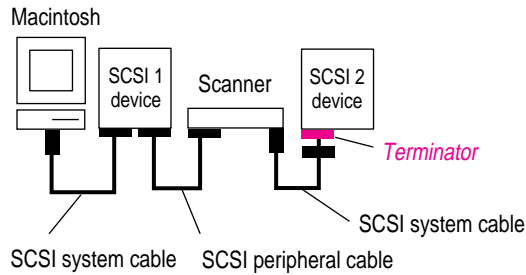

### Scanner Termination

- A SCSI terminator is needed on last device in chain.
- Set scanner SCSI ID to number 2, termination off.
- You can change the scanner ID number if you need to, but set termination off.

### Macintosh IIx only

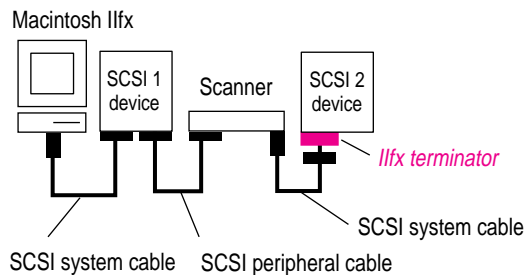

### Scanner Termination

- Use special Apple Macintosh IIx SCSI terminator on last device in chain.
- Set scanner SCSI ID to number 2, termination off.
- You can change the scanner ID number if you need to, but leave termination off.

### Macintosh PowerBook only

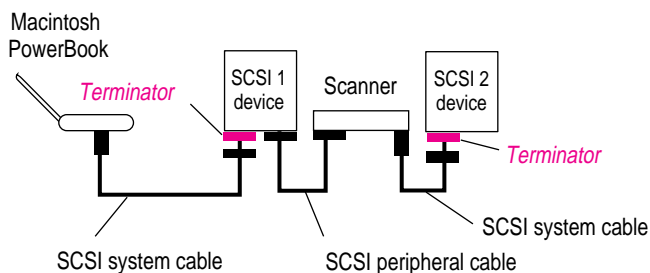

### Scanner Termination

- Terminator needed at start and end of SCSI chain.
- Set scanner SCSI ID to number 2, termination off.
- You can change the scanner ID number if you need to, but leave termination off.



## Index

•••••

### A

accessory kit, unpacking 6  
Actual Size command (Image menu) 104  
Agfa Optima 400 135-24 film 148  
Agfa XRS film 148  
alias, using to install plug-in module 22  
aligning originals 29  
Apple Color OneScanner dialog box 36,  
50, 147  
    controls not visible 36  
Apple Color OneScanner plug-in module.  
    *See also* scanner  
    installing 22–23  
    using with graphics applications  
    49–50  
Apple OneScanner Dispatcher  
    application, installing 19–22  
Apple service centers 149  
applications  
    adding to drag-and-drop icons 47–48  
    can't find scanner 156  
    installing Apple OneScanner  
        Dispatcher 19–22  
    using plug-in modules 22–23, 26  
Archive button (Dispatcher window) 33  
archives 43–44  
    viewing 88  
art, specifying type 42

assembling, SCSI chain 162–166  
Automatic Document Feeder  
    acceptable originals 117  
    bypassing 121  
    clearing jams 123–128  
    connector 10  
    diagram 116  
    indicating source of scan 36  
    maintenance 129–136  
    obtaining 90  
    problems 158  
    scanning multiple originals 118–120  
    setting up 113–116  
    troubleshooting 158

### B

background color, changing 64, 109  
background tool (tool palette) 64  
backup disks 20  
Black and White image option 36  
black lines on image 129  
books  
    aligning 30  
    scanning 28  
Brightness/Contrast command (Image  
    menu) 104  
brightness level 53–54, 78, 104  
brush palette, image-editing tools 64, 109

## C

- cable
  - connecting and disconnecting 13–14
  - connecting Transparent Media Adapter 141
  - SCSI 6, 7
  - terminator 13
- carriage, unlocking 11
- characters, converting to recognizable text 89
- cleaning
  - Automatic Document Feeder 129
  - scanner 111–112
  - Transparent Media Adapter 149–150
- Clear command (Edit menu) 103
- clearing paper jams 123–128
- clips, retaining 14
- clone tool (tool palette) 64, 109
- cloning an image 72–74
- Close command (File menu) 99
- color
  - adding 64
  - art 42
  - available 109
  - balance 79
  - changing 65
  - image option 36
  - maintaining consistency 20, 25
  - palette for editing 65, 109
  - reproducing consistently 87
  - resetting values 55–56
  - space 69
  - using Transparent Media Adapter 151
- color art, sending from scanner 42–43
- color images, scanning in document feeder 118
- ColorSync Preferences command (Image menu) 107
- ColorSync Preferences dialog box 87
- ColorSync system program 20
  - setting preferences 87
  - setting up 25
- commands (Dispatcher)
  - Actual Size (Image menu) 104
  - Brightness/Contrast (Image menu) 104
  - Clear (Edit menu) 103
  - Close command (File menu) 99
  - ColorSync Preferences (Image menu) 107
  - Copy (Edit menu) 102
  - Crop (Image menu) 105
  - Cut (Edit menu) 102
  - Dispatcher (Window menu) 108
  - Effects (Image menu) 106
  - Flip (Image menu) 106
  - Get Info (File menu) 100
  - Hide (Show) Brushes (Window menu) 108
  - Hide (Show) Colors (Window menu) 108
  - Hide (Show) Tools (Window menu) 107
  - Image Depth (Image menu) 106
  - Invert (Image menu) 104
  - New Archive (File menu) 98
  - New Image (File menu) 97
  - New Scan (File menu) 97
  - Open Archive (File menu) 99
  - Open Image (File menu) 98
  - Page Setup (File menu) 101
  - Paste (Edit menu) 103
  - Print (File menu) 101
  - Print Archive View (File menu) 102
  - Quit (File menu) 102
  - Resize (Image menu) 105
  - Revert (File menu) 101
  - Rotate (Image menu) 106
  - Save (File menu) 100
  - Save As (File menu) 101
  - Scan Router (File Menu) 99
  - Select All (Deselect) (Edit menu) 103
  - Sharpen (Image menu) 105
  - Undo (Redo) (Edit menu) 102
  - View By (Image menu) 107
  - Zoom In (Image menu) 104
  - Zoom Out (Image menu) 104



- communications regulation information
  - vii-viii
- computer screen, scanning resolution
  - for 52
- connecting scanner
  - to Automatic Document Feeder 10
  - to Macintosh 13–15
  - SCSI cable 14
  - to Transparent Media Adapter 10
- contrast
  - adjusting in images 78
  - changing 53–54
- Contrast option (Select a Range) 54
- Copy command (Edit menu) 102
- copying selections 75, 102
- copyright regulations 59
- cover 10–11, 31
- Crop command (Image menu) 105
- cropping
  - adjusting 38
  - scanned image 84, 105
- custom installation 21
- custom settings for scanning 51–55
- Cut command (Edit menu) 102
- cutting and pasting selections 75–76, 102

## D

- darkness level (threshold) 55–56
- dashed line (marquee) 66
- delivery guide sheet, replacing 130–133
- destination, indicating 36
- dialog boxes
  - Apple Color OneScanner 36, 50
  - ColorSync Preferences 87
  - Resize 82
  - Scanner Install Script 21
  - Scan Router 42
  - TextBridge 93
  - Threshold 56
  - Tone 54
  - Unsharp Masking 80
- diffuser
  - cleaning 150
  - location 139

- dimensions, changing 57
- disks
  - backing up 20
  - installation 19
- Dispatcher, assigning fax applications
  - to 42
- Dispatcher command (Window menu) 108
- Dispatcher window 24, 32, 46–48, 89
- document feeder. *See* Automatic Document Feeder
- document glass, cleaning 112
- documents. *See also* originals
  - copying an image into 75
  - placing on glass 29
  - problems in document feeder 117
  - restrictions 28
  - sizes 153
- dots per inch, setting 51–52
- drag-and-drop icons 24
  - in Dispatcher window 34, 47–48
  - TextBridge application 89
- drawing lines 71
- drawings and calligraphy. *See* originals
- driver for scanner 19

## E

- Easy Install 21
- editing images 33
- editing tools 63, 68–74
- Effects command (Image menu) 106
- Ektapress film 148
- Ektar 100 film 148
- electrostatic buildup 8
- environment for scanner 8, 154
- EPS (Encapsulated PostScript Language)
  - image format 41
- eraser tool (tool palette) 64, 109
- erasing 64, 70, 109
- extension cords 9
- external SCSI devices 7

## F

- fax applications
  - assigning to Dispatcher 42
  - sending new images to 33
  - sending saved images to 34
- Fax drag-and-drop icon 34, 42
- faxing images 34, 42–43
  - directly from scanner 42–43
  - scanning resolution 52
  - stored image 45–46
- file formats
  - choosing 100
  - text 91
- files
  - image format 41
  - installing for scanning 20–22
- film
  - aligning 146
  - dirty 152
  - handling 141
  - inserting into film guide 142–144
  - light correction zone 146
  - overexposure 142
  - scanning 137
  - selecting type 148
  - sizes for scanning 142
- fingerprints, avoiding 144
- Flip command (Image menu) 106
- flipping scanned images 84, 106
- foreground color, changing 64, 108–109
- foreground color tool (tool palette) 64
- formats
  - choosing 100
  - for scanned images 41
  - text 91

## G

- Get Info command (File menu) 100
- GIF image format 41
- glass, cleaning 112
- grabber (Threshold dialog box) 55–56

- grabber tool (tool palette) 64, 108
- graphics applications, scanning into 49–50
- grayscale art 42–43
- Gray Scale image option 36
- grounding plug 15

## H

- Halftone image option 36
- hard disk drive, requirements 2, 20
- Hide (Show) Brushes command (Window menu) 108
- Hide (Show) Colors command (Window menu) 108
- Hide (Show) Tools command (Window menu) 107
- Highlight dropper (Threshold dialog box) 56
- Horizontal flips 84
- HTML documents
  - converting text image to 94
  - opening 43–44
- HTML format, saving files to 89
- Hypertext Markup Language (HTML) 43–44, 89, 94

## I

- icons
  - drag-and-drop 24, 34, 47–48
  - OCR 25
  - OneScanner Dispatcher 23, 32, 155
  - unassigned 47–48
- ID number, setting 12
- Image Depth command (Image menu) 106
- image document. *See* scanned images
- Image Edit button 33
- image-editing tools 64–74, 108–110
- Image1 document 39

- images. *See also* scanned images; scanning images
  - automatic adjustments 38–39
  - changing ruler units 57
  - changing size 39
  - choosing type 36
  - custom options 51–56
  - depth 87
  - editing 33
  - editing tools 64, 68–74, 108–109
  - faxing or printing from scanner 42–43
  - from film 137
  - formats 41
  - opening saved 44
  - previewing 37, 63
  - printing or faxing saved images 45–46
  - quality problems 150–152
  - renaming 40–41, 45
  - saving documents 40–41
  - scanning options 36–38
  - selecting name 63
  - sending to printer or fax 33
  - sharpening 105
  - sideways 84
  - specifying type of 42
  - from transparencies 137
  - upside-down 84
- information, reference 3
- inkjet printer, scanning resolution 52
- installation disks 19–20
- Installer program 19
- installing
  - Apple Color OneScanner plug-in module 22–23
  - scanner software 20–22
  - Transparent Media Adapter 137–141
- interference
  - electromagnetic 9
  - radio and television vii
- internal termination, SCSI 13
- Internet
  - converting text files for 94
  - image format for 41
- Invert command (Image menu) 104
- irregular shape, selecting 67

## J

- JPEG (Joint Photographic Experts Group) image format 41

## K

- Kai's Power Tools and Convolver, installing 26

## L

- lamp, in Transparent Media Adapter 150
- laser printer, scanning resolution 52
- lasso tool (tool palette) 64, 108
- legal-size paper, in document feeder 118
- light, power on 10
- light correction zone 146, 150
- line, dashed 66
- line art 28
- line drawings, sending from scanner 42–43
- Linotronic imagesetter, scanning resolution 52
- loading Automatic Document Feeder 118–119
- locking scanner 11

## M

- MacDraw Pro application, scanning images for 47–48, 49
- Macintosh
  - connecting scanner in SCSI chain 163–166
  - connecting SCSI cable 14
- Macintosh PowerBook, connecting SCSI power devices 13
- Macintosh skills, help with 2
- Macintosh IIfx, connecting scanner to 6 magazines. *See* originals
- maintaining Automatic Document Feeder
  - cleaning 129
  - replacing delivery guide sheet 130–133

- maintenance
    - scanner 111–112
    - Transparent Media Adapter 149–150
  - marquee 66
  - memory
    - and image resolution 42
    - requirements 2
  - messages
    - application can't find the scanner 156
    - computer can't see document
      - feeder 158
      - not enough space on hard disk 157
  - monitor, frozen 156
  - moving selections 68
- N**
- names of images 39
  - negatives
    - avoiding overexposure 142–143
    - scanning 77, 137
  - New Archive command (File menu) 98
  - New Image command (File menu) 97
  - New Scan command (File menu) 97
  - noises, strange 157
- O**
- OCR (optical character recognition)
    - icons 25
    - installing 23–25
    - scanning 90–91
  - OCR-to-HTML converter 89
  - OneScanner Dispatcher application
    - automatic settings 35–39
    - buttons 33
    - disks 19
    - Edit menu commands 102–103
    - File menu commands 96–102
    - icon 23, 32
    - image-editing tools 108–109
    - Image menu commands 103–107
    - opening 32, 62
    - organization 33–34
    - sending text to Xerox TextBridge
      - application 89–93
      - setting up transparencies 147–148
      - Window menu commands 107–108
    - on/off switch 10, 16
    - Open Archive command (File menu) 99
    - Open Image command (File menu) 98
    - optical character recognition programs.
      - See* OCR
    - orientation, automatic setting 38
    - originals
      - aligning 29–30
      - damaged 121
      - loading multiple 113
      - preparing 28
      - problems with 117
      - scannable 28, 117
      - using Automatic Document Feeder
        - 118–120
    - output devices, setting scanning
      - resolution 52
    - overexposure, avoiding 142
    - overhead transparencies 137
    - overheating 8
- P**
- packing scanner 11
  - Page Setup command (File menu) 101
  - paintbrush tool (tool palette) 64, 109
  - paint bucket 64
  - paint bucket tool (tool palette) 109
  - painting
    - with brushes 72
    - spray 71
  - painting tools, setting shape for 64
  - palettes. *See also* editing tools
    - showing and hiding 65
  - paper. *See* originals
  - paper jams
    - clearing 123–128
    - diagram of path 122

- paper separator, replacing 134–136
- Paste command (Edit menu) 103
- pasting selections 75, 103
- Pencil tool (tool palette) 64, 109
- peripheral cable, SCSI 6
- photographs. *See also* originals
  - handling film 141
  - printing 101
  - scanning 137
  - sending from scanner 42–43
- Photoshop-compatible plug-in filters 106
- Photoshop image format 41
- PICT image format 41
- plug-in module
  - installing 22–23, 26
  - using with graphic applications 49–50
- positive images 77
- power, switching on and off 16
- PowerBook computer, connecting scanner to 6
- power cord 6
  - connecting 15
  - extension 9
  - socket 10
- power on light 10, 155
  - going on and off 156
- power requirements 154
- power source 8
- precautions, safety 9
- preview image 37–38
- Print Archive View command (File menu) 102
- Print command (File menu) 101
- Print drag-and-drop icon 34
- printer
  - receiving images from scanner 42–43
  - sending new images to 33
  - sending saved images to 34
- printing
  - saved images 45–46
  - from scanner 33–34

## Q

- Quit command (File menu) 102

## R

- radio interference vii
- RAM requirements 2, 20
- Read Me file 19
- regular shape, selecting 66
- removing scanner cover 31
- renaming saved image 45
- replacing scanner cover 31
- requirements, system 2, 20
- Resize command (Image menu) 105
- Resize dialog box 82
- resolution
  - automatic setting 37
  - custom setting 51–52
  - recommended 52
  - of scanned images 39
- restarting computer 22
- retaining clips 14
- Revert command (File menu) 101
- Rotate command (Image menu) 106
- rotating scanned images 85, 106
- ruler units 58

## S

- safety
  - features 15
  - precautions 9, 17
- Save As command (File menu) 101
- Save command (File menu) 100
- saved images
  - opening from archive 43
  - printing or faxing 45–46
- Scan button (Dispatcher window) 33
- scanned images
  - adjusting brightness and color 78
  - changing color balance 79
  - changing view of archives 88
  - choosing format 40–41
  - copying 75–76
  - cropping 83
  - customizing 55–57
  - cutting 75–76
  - deleting 75–76
  - editing tools 68–75

- flipping 84
- inverting from positive to negative 77
- opening 62–63
- poor quality 150–152
- resizing 82
- saving 40–41, 100
- selecting 66–67
- sending to fax application or printer 42–43
- setting ColorSync preferences 87
- setting image depth 86
- sharpening 80–81
- using palettes 64–65
- Scanned Text window 93
- scanner
  - adapting for transparencies 137
  - carrying 9
  - choosing location 7–8
  - cleaning 111–112
  - connecting 6–7
  - connecting power cord 15
  - connecting to Macintosh 13–14
  - connecting Transparent Media Adapter 138–141
  - cover 31
  - driver 19
  - locking or unlocking 11
  - maintenance 111–112
  - moving or shipping 11
  - parts 10
  - placing 8
  - removing and replacing scanner cover 31
  - repacking 11
  - safety information 17
  - setting SCSI ID number 12
  - setting up document feeder 113–116
  - technical specifications 153–154
  - troubleshooting 155–157
  - unpacking 6
  - uses 1
- scanner files, installing 20–22
- scanner icon 155
- Scanner Install Script dialog box 21
- scanning area, extending 28
- scanning images. *See also* Automatic Document Feeder; Transparent Media Adapter
  - automatic settings 35–39
  - changing image size and ruler units 57–58
  - custom settings 51–56
  - Dispatcher window 33–34
  - with document feeder 118–120
  - film 145–148
  - into graphics application 49–50
  - new 33
  - opening OneScanner Dispatcher application 32
  - preparing originals 28–30
  - printing 45–46
  - saving 40–41, 43–44
  - scannable items 28
  - sending to fax application or printer 42–43, 45–46
  - setting options 36–38
  - transparencies 145–148
  - troubleshooting 158
  - using Transparent Media Adapter 137
- scanning text
  - for use with OCR documents 89
  - into Xerox TextBridge application 90–93
- Scan Router button (Dispatcher window) 33
- Scan Router command (File menu) 99
- Scan Router dialog box 42
- scratches, on Transparent Media Adapter 148
- scrolling image 39
- SCSI cable
  - choosing 6–7
  - connecting 13

- SCSI chain
    - assembling 162–166
    - connecting devices 7, 161–162
    - ID numbers 159–160
    - termination 160–161
  - SCSI connectors 10
  - SCSI drivers, power-on sequence
    - 114, 138
  - SCSI ID and termination selector 10
  - SCSI ID number and termination,
    - selecting 12–13, 155
  - Select All (Deselect) command (Edit menu) 103
  - selection marquee (dashed line) 38
  - Selection rectangle tool (tool palette)
    - 64, 108
  - setup
    - Automatic Document Feeder 113–116
    - scanner 5
    - Transparent Media Adapter 137–141
  - Shadow dropper (Threshold dialog box)
    - 55–56
  - shapes, selecting 67
  - Sharpen command (Image menu) 105
  - sharpening images 80–81
  - shutter strips 142–144
  - Smudge tool (tool palette) 64, 109
  - smudging 74
  - software
    - installing for scanner 19–25
    - requirements 2
  - Source pop-up menu, dim 158
  - spray can tool (tool palette) 64, 109
  - spray painting 71
  - static buildup 8
  - straighten image 38
  - switch
    - on/off 10, 16
    - SCSI ID selector 12
  - switching, power on 16
  - system cable, SCSI 6
  - system hangs 156
  - system requirements 2, 20
- T**
- technical specifications 153–154
  - television interference vii
  - termination. *See also* SCSI chain
    - settings 13
  - terminators, purchasing 6
  - text
    - adding 64, 70
    - moving into Xerox TextBridge
      - application 92–93
    - scanning into Xerox TextBridge
      - application 90–91
  - text and optical character, scanning 28
  - TextBridge application. *See* Xerox TextBridge application
  - TextBridge dialog box 93
  - text images, converting to HTML 94
  - text/line art 42
  - Text tool (tool palette) 64, 109
  - threshold, changing 55–57
  - Threshold dialog box 55–57
  - thumbnail representations 41, 43–44
  - TIFF (Tagged-Image File Format) image
    - format 41, 91
  - tone
    - adjusting 36
    - custom settings 53–55
  - Tone dialog box 54
  - tool palette
    - for editing 64
    - image editing 64
    - image-editing tools 108–109
    - showing and hiding 65
  - tools, editing 64, 68–74, 108–109
  - transparencies
    - dirty 152
    - scanning 145–148
  - Transparent Media Adapter
    - bypassing 148
    - connector 10
    - handling film 141
    - indicating source of scan 36
    - inserting film for scanning 142–144

- maintenance 149–150
- overexposure 142, 152
- scanning film and transparencies 145–148
- setting up 137–141
- troubleshooting 150–152
- unlocking 139
- transparent media alignment guide 139
- troubleshooting
  - Automatic Document Feeder 158
  - image quality 158
  - scanning and hardware 155–157
  - Transparent Media Adapter 150–152

## U

- Unassigned drag-and-drop icons 34
- Undo (Redo) command (Edit menu) 76, 102
- unlocking scanner 11
- Unsharp Masking dialog box 80

## V

- Vertical flips 84
- vibrations 8
- View By command (Image menu) 107
- virus-detection programs 20

## W

- whole image, selecting and deselecting 67
- windows
  - Dispatcher 24, 32, 46–48, 89
  - Scanned Text 93
- Windows BMP image format 41
- work areas 8–9

## X, Y

- Xerox TextBridge application 89
  - assigning to Dispatcher 23–25
  - converting files to text in HTML format 94
  - installing 90
  - moving text into 92–93
  - scanning into 90–91

## Z

- Zoom In command (Image menu) 104
- zooming in and out 69, 76, 104
- Zoom Out command (Image menu) 104
- Zoom button (Threshold dialog box) 55–56
- Zoom tool (tool palette) 64, 109



**Apple Computer, Inc.**

1 Infinite Loop

Cupertino, California 95014-2084

408-996-1010

<http://www.apple.com>

030-9440-A

Printed in U.S.A.