

# 1

## Setting Up Your Printer



This chapter introduces the Apple Color StyleWriter 4500 printer and explains how to set it up. After you follow the instructions in this chapter, you'll be ready to print.

### Important safety instructions

Always take the following precautions:

- Keep the printer cover closed when printing.
- Always turn off the printer before unplugging it.
- Keep the ink cartridges away from children.
- Keep the printer away from sources of liquid, such as wash basins, bathtubs, and shower stalls.
- Protect the printer from dampness or wet weather, such as rain and snow.
- Read all the installation instructions carefully before you plug the printer into a wall socket.
- Keep these instructions handy for reference by you and others.
- Follow all instructions and warnings dealing with your computer system.
- Don't use devices that produce open flames, such as Bunsen burners, near the printer.

- Don't use alcohol-based or ammonia-based cleaners on or around the printer.
- Always unplug the printer before cleaning it. (Use only the cleaning procedure recommended in Chapter 4.)
- Clean the outside of the printer with a damp cloth and, if necessary, a mild soap or detergent. Be careful not to get liquid into the printer or the power cord receptacle.

**IMPORTANT** The only way to disconnect power completely is to unplug the power adapter. Make sure at least one end of the power cord is within easy reach so that you can unplug the Color StyleWriter 4500 when you need to.

**Watch for these situations, and if one occurs pull the plug!**

- the power cord or plug becomes frayed or otherwise damaged
- you spill something into the printer
- the printer is exposed to rain or any other excess moisture
- the printer has been dropped or otherwise damaged
- you suspect that your printer needs service or repair

**WARNING** Electrical equipment may be hazardous if misused. Operation of this product, or similar products, must always be supervised by an adult. Do not allow children access to the interior of any electrical product and do not permit them to handle any cables.



## Unpacking the printer

- 1 Remove everything from the shipping box, but leave the ink cartridges in their packages.

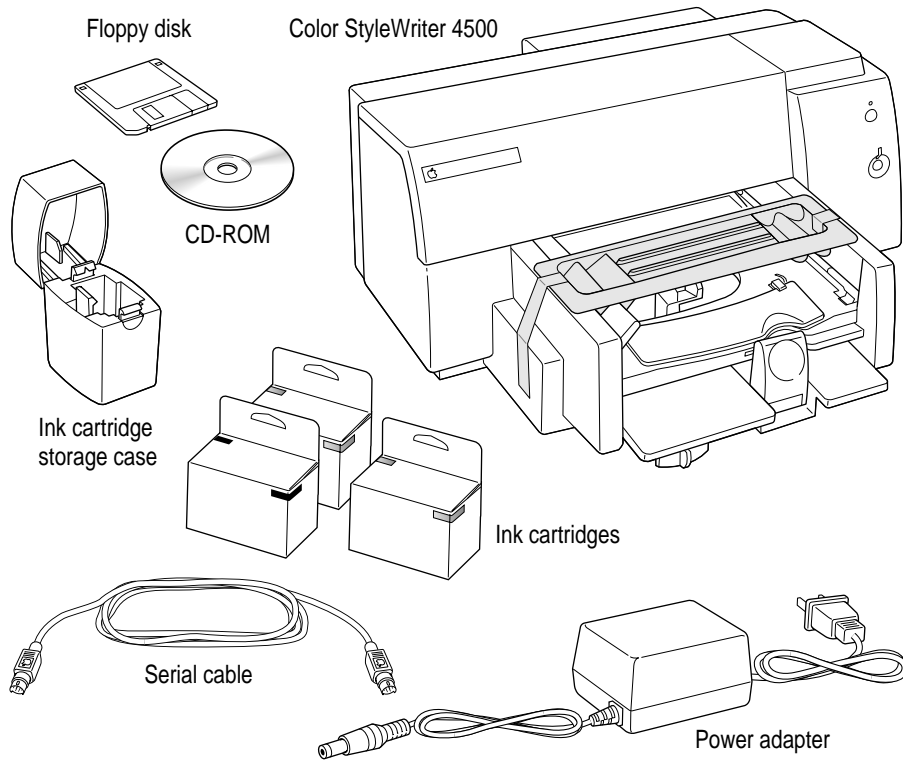

- 2 Remove the tape and packing material from the outside of the printer.

- 3 Open the printer's cover and remove the packing material from the inside of the printer.

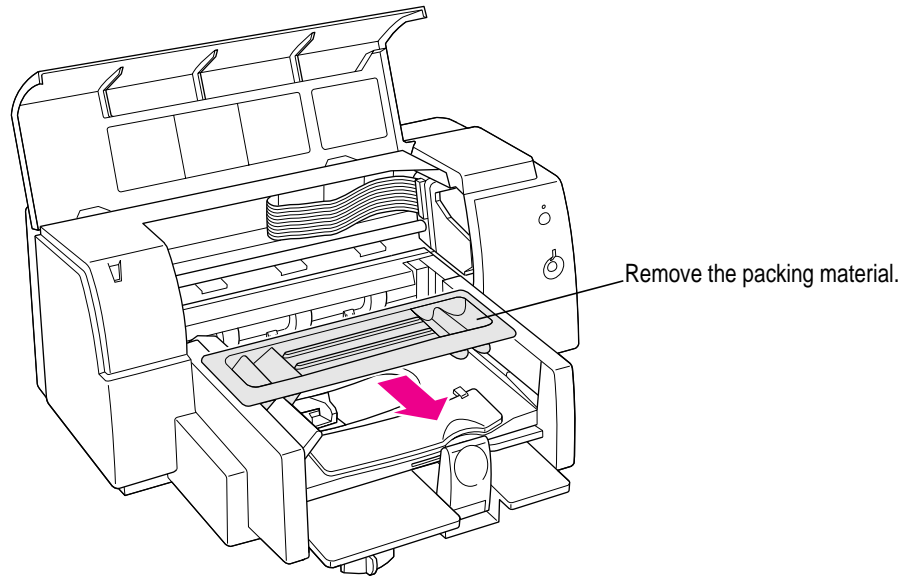

Save the carton and the packing material in case you ever need to ship the printer.

- 4 Close the printer's cover.
- 5 Place the printer in your work area.

Choose a location near your computer that has an electrical outlet and good ventilation, is out of direct sunlight, never gets damp or very hot or very cold, and is away from devices that could cause electromagnetic interference, such as stereo speakers or cordless telephone transmitters. Do not place the printer on a slanted surface. See Appendix A, "Technical Information," for specific information about the physical requirements of your printer.

**IMPORTANT** Don't accidentally discard the ink cartridge storage case. You need it to store an opened cartridge that you're not using in the printer. The case keeps the print head from drying out and prevents accidents with ink stains.

## Plugging in the printer

Plug the connector end of the power adapter into the printer and then plug the other end of the adapter into an outlet.

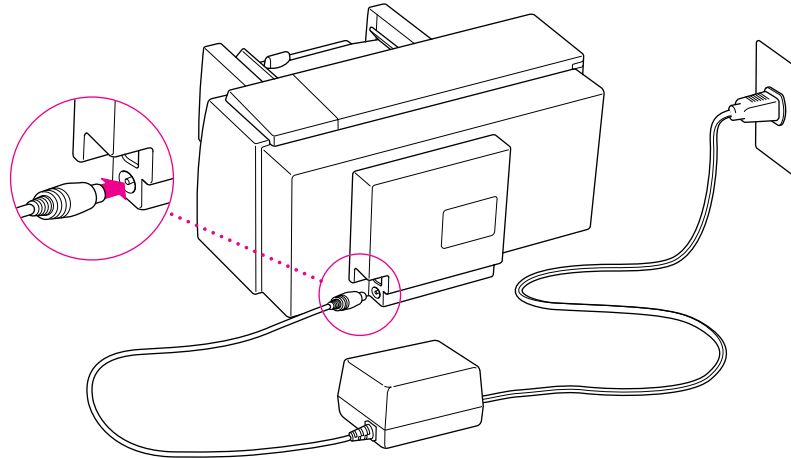

**IMPORTANT** The only way to disconnect power completely is to unplug the power adapter. Make sure that at least one end of the power cord is within easy reach so that you can unplug the printer in an emergency.

**WARNING** The Color StyleWriter 4500 is designed to work with the electrical system of the region in which you purchased it. It works with only one frequency of electricity, either 50 or 60 Hz. The label on the adapter you received with your printer indicates the frequency required.

The label on the adapter also indicates the voltage required. If you are using the printer in a region with a different voltage but the same frequency as that listed on the adapter, you must use a voltage converter to provide the voltage indicated on the adapter label.

Serious damage to the printer will result from using the Color StyleWriter 4500 adapter with an improper electrical frequency or improper voltage converter. Damage resulting from such misuse of the printer is not covered under warranty.

## Connecting the printer directly to your computer

You can connect the printer directly to your computer with a serial cable. If you want to add the printer to a LocalTalk network, see the next section, “Connecting to a LocalTalk Network.” You cannot connect the printer both ways.

### 1 Plug the cable into the interface port on the printer.

You can use the serial cable that came with your printer, or you can use a LocalTalk kit and plug a LocalTalk cable into the same port.

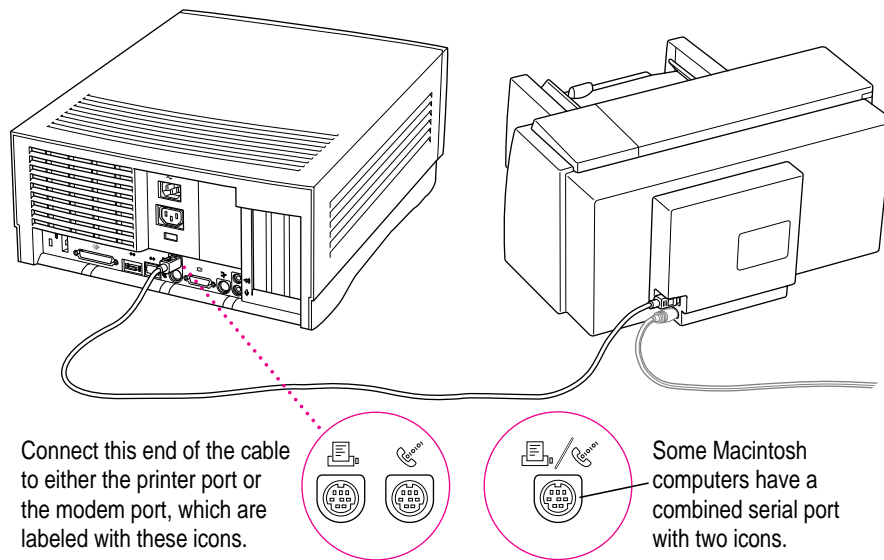

### 2 Plug the other end of the cable into the printer port on your computer.

If your computer is connected to a network, a network cable may already be connected to the printer port (🖨️). In that case, use the modem port (📞).

Remember which port on the computer you use. Later you must tell the printer software where to look for the printer.

Some PowerBook computers that have an internal modem installed cannot tell that the printer is plugged in. You must change a setting in the PowerBook Setup or Express Modem control panel. For details, see “Special Information for PowerBook Owners” in the section “Telling Your Computer to Use the Color StyleWriter 4500,” later in this chapter.

## Connecting to a LocalTalk network (optional)

If you have an existing LocalTalk network, you can add your printer to it and share the printer with other Mac OS–based computers on the network.

**IMPORTANT** You can either connect the printer directly to your computer with a serial cable or connect it to a LocalTalk network with a LocalTalk connecting kit. You cannot connect the printer both ways at the same time.

**1 Obtain a LocalTalk connecting kit.**

LocalTalk connecting kits come in many varieties. A kit usually contains one connector box and one LocalTalk cable. Two LocalTalk connecting kits are available from Apple. For information about these kits, see “Apple Printer Supplies and Accessories” in Appendix A.

**2 Plug the connector box into the interface port on the printer.**

**3 Connect the printer to the network in one of these two ways:**

- *To connect the printer to the end of a LocalTalk network*, use the LocalTalk cable to connect the empty socket of the nearest device’s connector box to the printer’s connector box.
- *To connect the printer between two devices on a LocalTalk network*, disconnect one LocalTalk cable from the connector box or the device immediately to the left or right of the printer and plug it into the new printer’s connector box. Then use the new LocalTalk cable to connect the free socket on the printer’s connector box to the socket you freed on the other device’s connector box.

## Turning the printer on and off

To turn on the printer, press the power button. The green power light glows.

To turn the printer off, press the power button again. The power light goes out.

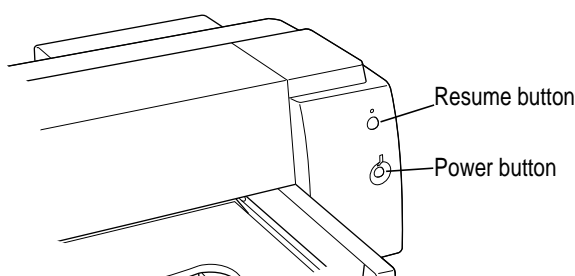

**WARNING** Except in an emergency, make sure the printer is turned off before you unplug it. (When the power light is off, the power is off.) If the printer is plugged into a power strip, never turn off the power strip unless you've already turned the printer off.

When you turn off the printer, it moves the ink cartridges to the right, where it caps the nozzles to keep the ink cartridges from drying out. If you unplug the printer or discontinue power before turning it off, the printer can't position the cartridges in the capped position, the print head may dry out, and you'll have to replace the cartridge.

## Power Macintosh users and virtual memory

If you are using a Power Macintosh computer, you may want to turn on virtual memory before you try to print on the Color StyleWriter 4500. Then choose a setting that's at least 1 MB higher than your "Available built-in memory." (You can set it higher without any ill effects.) With this setting, you will avoid some potential printing problems. Turning on virtual memory also reduces the amount of memory needed by many applications. For instructions on turning on virtual memory, see the documentation that came with your computer.



## Installing the ink cartridges

Each ink cartridge contains a print head, which sprays the ink onto the paper. Treat it gently so you don't damage its tiny nozzles.

**WARNING** The carrier holds the ink cartridges and moves them back and forth when you are printing a document. Don't slide the carrier by hand or you will damage the printer.

- 1 To turn on your printer, press the power button.

The power light comes on.

- 2 Open the front cover.

The carrier moves to the center of the printer, and the resume light flashes.

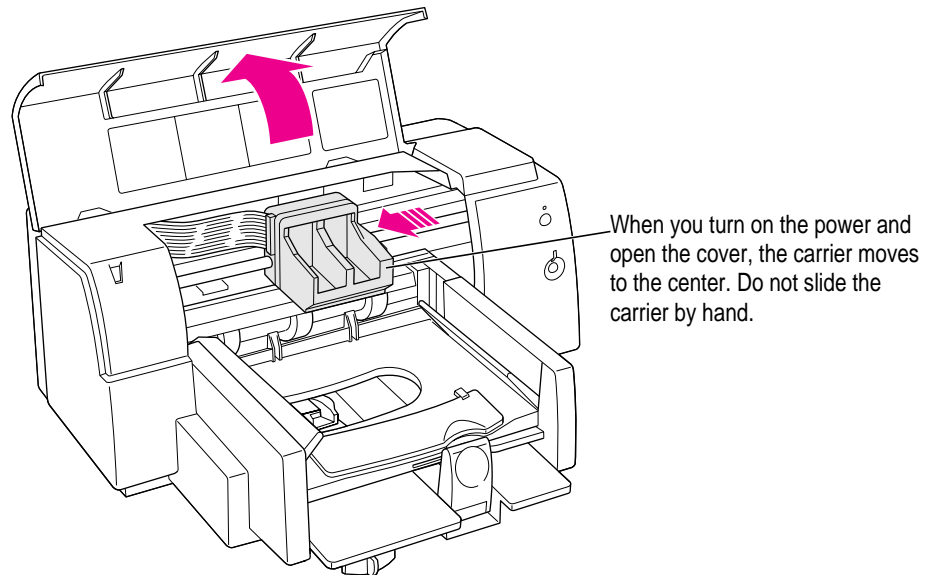

*Note:* If the carrier does not move automatically to the center, try closing the cover and turning the power off. Then repeat steps 1 and 2.

**WARNING** Use only ink designed for use with the Color StyleWriter 4500.

- 3 Grasp each ink cartridge by its sides and carefully remove the tape from the cartridge's print head.**

You may safely touch the colorful caps or the black plastic, but be careful not to touch any other part.

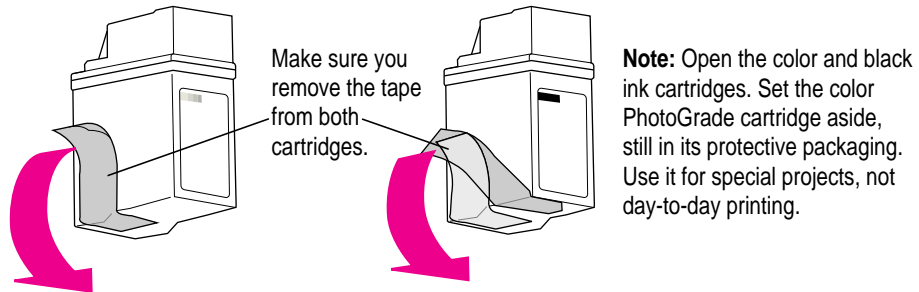

- 4 Slide the ink cartridges down into the carrier, and then press both cartridges into place.**

For the printer to work, you must install two ink cartridges.

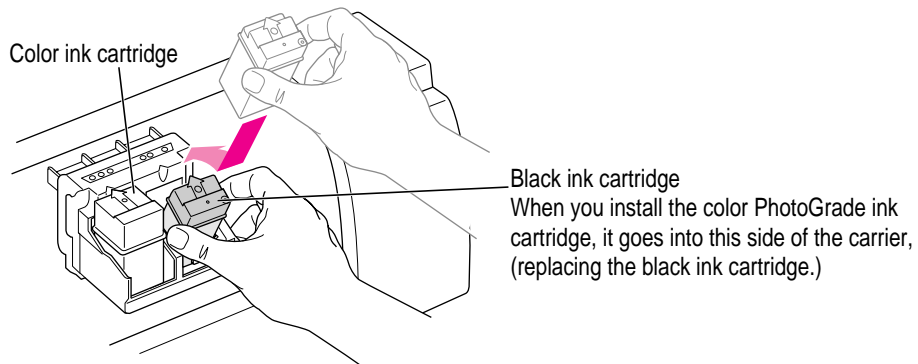

Press the cartridge all the way into the carrier.

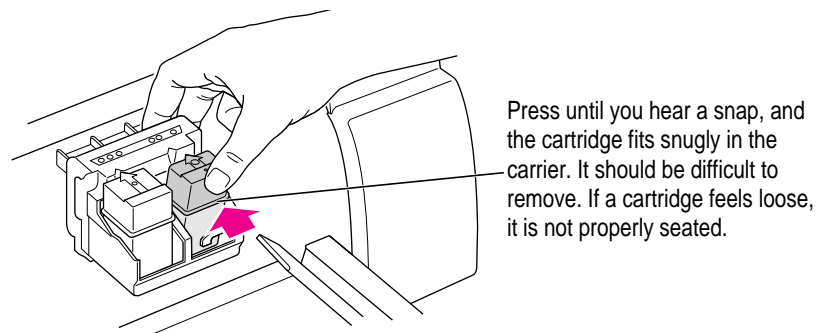

**5 Close the printer's front cover.**

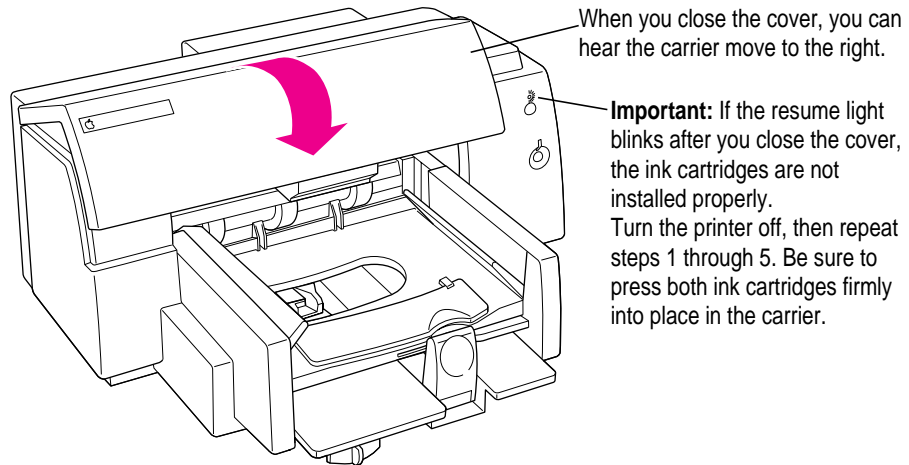

**Storing the ink cartridge you aren't using**

The Color StyleWriter 4500 comes with color, black, and color PhotoGrade cartridges. Sealed in their original packaging, the cartridges are protected. If you open all three packages and switch between the black and PhotoGrade cartridges for printing different documents, be sure to store the one you're not using in the storage case supplied with your Color StyleWriter 4500. The storage case keeps the print head from drying out and prevents accidents with ink stains.

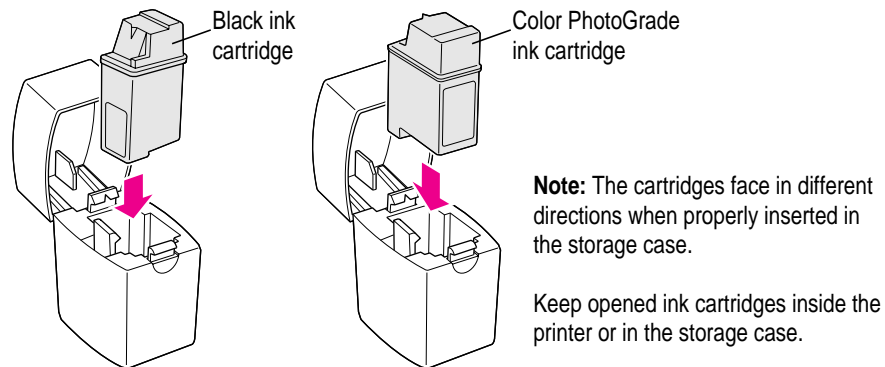

**IMPORTANT** If you are using only two cartridges, leave them inside the printer.

## Installing your printer software

Before you can print your documents, you need to install the printer software on your computer. The *Apple Printer Software Collection* CD-ROM that comes with the Color StyleWriter 4500 contains the printer software and an Installer program.

The Installer installs the new printing software you need, plus the fonts that come with the printer (see Appendix C for a list of available fonts).

If you have been using Apple's special QuickDraw GX software, turn it off now. The Color StyleWriter 4500 is not compatible with QuickDraw GX.

*Note:* If you ever upgrade your system software (for example, from System 7.1 to System 7.5), you must reinstall the Color StyleWriter 4500 software.

### Using the *Minimal Printer Software* floppy disk

If you have a CD-ROM drive, skip to the next section, "Using the *Apple Printer Software Collection* CD-ROM."

If you do not have a CD-ROM drive, the *Color StyleWriter 4000 Series Minimal Printer Software* floppy disk that came with your printer contains minimal software that lets you start printing now. For instructions on installing the software, see the Read Me you'll find on the floppy disk.

In addition, you can contact Apple and ask to have the complete Color StyleWriter 4500 printer software mailed to you on a set of floppy disks. If you prefer not to wait and have access to a computer with a CD-ROM drive, the *Apple Printer Software Collection* CD-ROM contains disk images of the complete set of floppy disks. The CD-ROM also contains a disk-duplication application you can use to create your own set of floppy disks. See the instructions that accompany the application.

*Note:* The minimal printer software works with a Color StyleWriter 4500 printer that is connected by a serial cable to your computer. If you want to use a LocalTalk kit to connect the printer, you must use the software that comes on the *complete* disk set.

Now you can go on to read the section "Telling Your Computer to Use the Color StyleWriter 4500," later in this chapter.

## Using the *Apple Printer Software Collection* CD-ROM

- 1 Turn off any automatic virus-detection applications you have on your Macintosh computer.

If you don't, problems may occur during the installation. After installation is complete, you can turn the virus-detection programs back on. (For instructions on turning off each virus-detection application, see the manual that came with the program.)

- 2 Insert *Apple Printer Software Collection* CD-ROM into your CD-ROM drive.
- 3 Open the Printer Software folder.

You may have to open the CD icon to see the Printer Software and Software Collection folders.

- 4 Open the Installer folder (inside the Printer Software folder).
- 5 To start the Installer program, double-click its icon.
- 6 In the Welcome dialog box that appears, click Continue.

**IMPORTANT** The Installer determines whether you have the correct system software, and enough memory and hard disk space to use this printer. If you don't, the Installer displays a message telling you what you need. You won't be able to install the printer software until you correct the system software or memory problem. If the message reports a problem, you can purchase new system software or memory from an Apple-authorized dealer, or make space available on your hard disk by throwing away files you don't need.

- 7 Read the software license agreement and click Agree.

If you are unwilling to accept the terms of the agreement, click Disagree.

**8 In the Installer dialog box, click Install.**

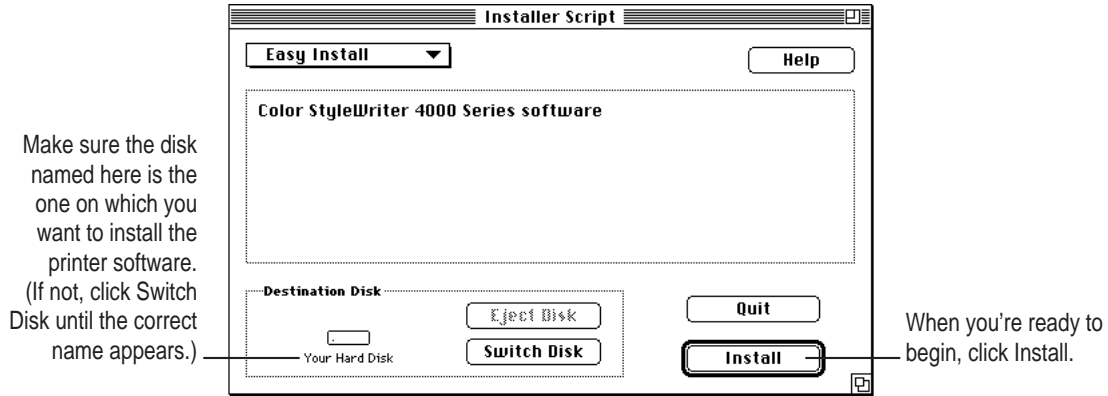

After a few moments, the Installer begins to install the printer software. A status box keeps you informed of progress during installation.

**9 When you see a message reporting that installation was successful, click Restart.**

## Installation troubleshooting

If the Installer can't complete the installation, it will issue a warning message. Here are some ways to fix common problems:

- You may not have the correct hardware or system software for this printer. If so, the Installer will tell you what you're missing.
- You may have forgotten to turn off your virus-detection software as described in the section "Using the *Color StyleWriter 4500 CD-ROM*," earlier in the manual.
- You may have some corrupted fonts on your hard disk. To solve this problem, see "Installation Is Unsuccessful" in Chapter 5.

## More information about the Installer program

In the procedure just described the Installer copies all the software you need to your hard disk. In rare circumstances you may want to copy only a subset of the software. In that case choose Custom Install from the pop-up menu in the Installer. When a list of choices appears, select the items you wish to install, then click the Install button. (Click the letter *i* to the right of any of the choices for information.)

## Telling your computer to use a directly connected Color StyleWriter 4500

If your printer is connected directly to your computer with a serial cable, follow these instructions for selecting it in the Chooser.

If your printer is connected to a LocalTalk network, see the next section, “Telling Your Computer to Use a Color StyleWriter on a LocalTalk Network.”

- 1 **Make sure the printer is turned on.**
- 2 **Select Chooser from the Apple () menu.**
- 3 **In the Chooser dialog box, click the appropriate items to select them.**

First, click this icon.  
(If necessary, use the scroll bar and arrows to find it.)

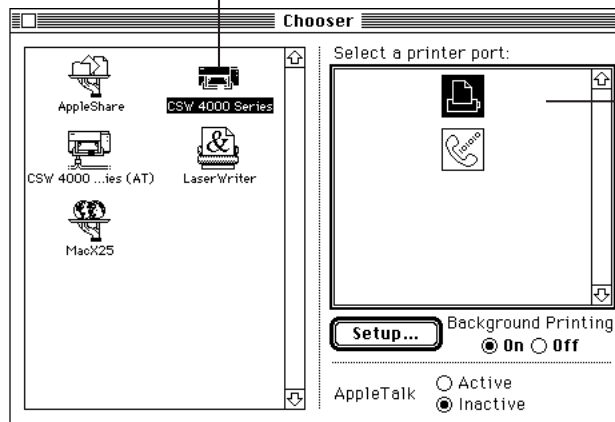

Then click one of these items to indicate which port you connected the printer to: the printer port (🖨️) or the modem port (📞).

If no port is available and your computer is a PowerBook, see “Special Information for PowerBook Owners,” later in this chapter.

- 4 **Close the Chooser by clicking the close box in its upper-left corner.**



## Telling your computer to use a Color StyleWriter on a LocalTalk network

You can connect a Color StyleWriter 4500 printer directly to a LocalTalk network.

*Note:* If you do not need to share the printer with other users on the network, connect the printer directly to your computer with the serial cable. The printer prints faster when connected this way.

Once the printer is on the network, its name appears in the Chooser just like the names of other network printers.

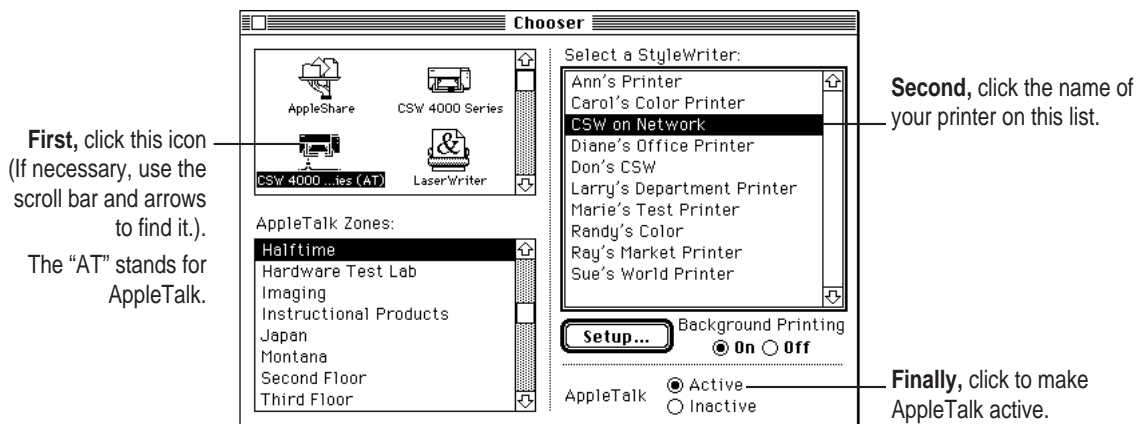

If you want to change the name, click Setup in the dialog box that appears, type a new name, and click Rename. (*Note:* Anyone on the network can change the name.)

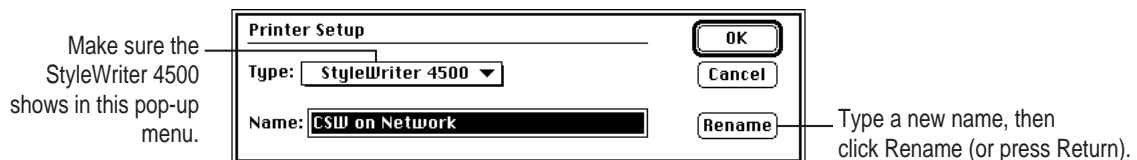

## Special information for PowerBook owners

PowerBook computers that have internal modems may require special setups. What you do depends on whether the Powerbook has one or two serial ports on its back panel.

*Note:* This information is for PowerBook users who connect the printer directly to their computer with a serial cable.

### PowerBook computers with one serial port

Some PowerBook computers have a single serial port identified by a combination printer/modem icon (☐/☎). If an internal modem is installed on one of these PowerBook computers, the serial port may be in use even though it looks available. When you plug in the Color StyleWriter 4500, the PowerBook may not be able to communicate with the printer.

To make the port available for printing, make sure the serial port setting is Normal or External. To check the setting, open the PowerBook, PowerBook Setup, or Express Modem control panel. (If you have another kind of internal modem, you may have a different control panel. The control panel and the setting you use depend on which PowerBook you have and which internal modem you have.) If you have a PowerBook Express Modem, it is best to leave the serial port setting as Normal or External unless the modem programs you use require another setting for compatibility reasons.

### PowerBook computers with two serial ports

Even when a PowerBook has two serial ports, if it also has an internal modem, the modem port (☎) may look available but actually be in use. If the printer port (☐) is available, connect the Color StyleWriter 4500 to it. If the printer port is unavailable and you must use the modem port, make sure the modem serial port setting is Normal or External. To check the setting, open the PowerBook, PowerBook Setup, or Express Modem control panel. (If you have another kind of internal modem, you may have a different control panel. The control panel and the setting you use depend on which modem and system software version you have.) If you have a PowerBook Express Modem, it is best to leave the serial port setting as Normal or External.

For more information, see the instructions that came with your PowerBook.

## Loading paper into the paper tray

The paper tray holds up to 100 sheets of 20-pound paper and feeds the paper automatically into the printer. You can load many sizes of paper and other media into the sheet feeder as described in Chapter 2, but to align the ink cartridges, as described in the next section, you must use U.S. letter-size or A4 paper. To load paper into the sheet feeder, follow these steps:

- 1 Slide the paper adjusters out as far as you can.

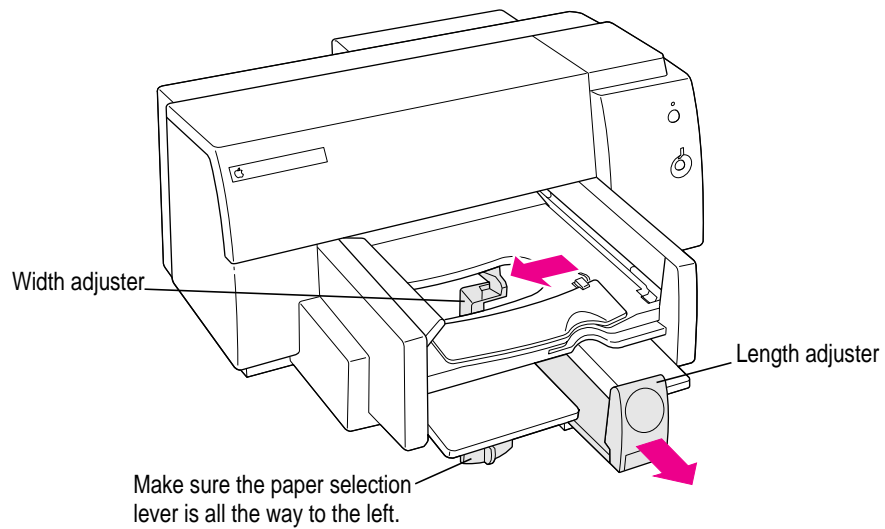

- 2 Make sure the edges are even on all sides before inserting a stack of paper.

**3 Load the paper into the lower tray, print side down.**

The wrapper that the paper comes in usually tells which side to print first.

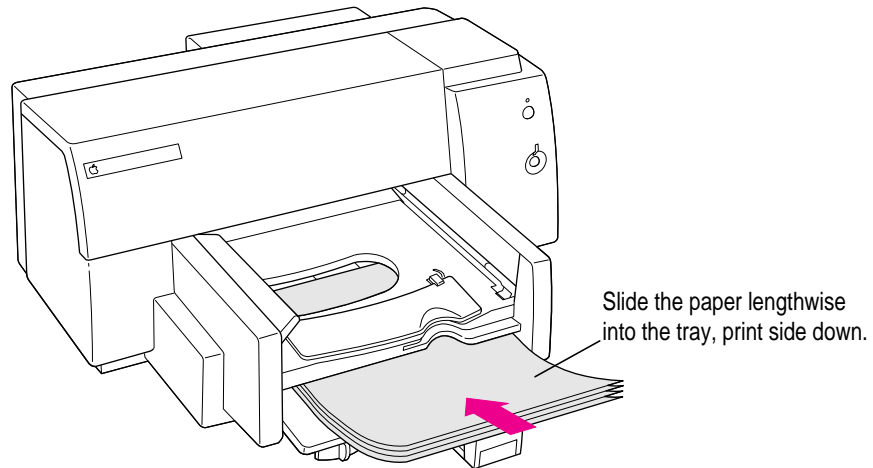

*Note:* Illustrations inside the printer cover remind you how to insert paper and envelopes correctly.

**4 Slide the paper adjusters in to touch the edges of the stack of paper.**

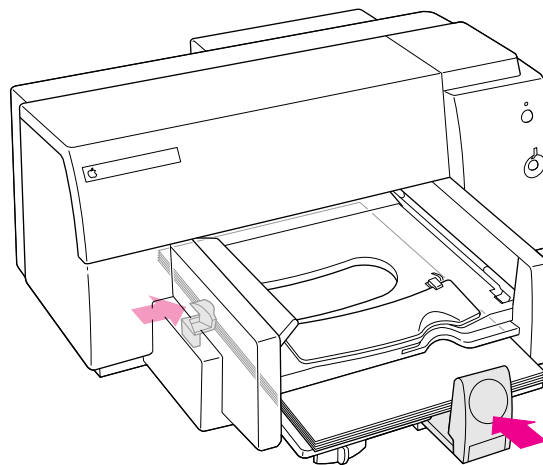

## Aligning the ink cartridges

Whenever you install a new ink cartridge, follow these steps:

- 1 If necessary, turn on the printer.

The green power light should be on.

**IMPORTANT** If the resume light blinks, the ink cartridges are not installed properly. Turn the printer off. Then follow the steps in “Installing the Ink Cartridges,” earlier in this chapter.

- 2 Make sure there is plain paper in the paper tray.
- 3 Choose Page Setup from the File menu.
- 4 In the Page Setup dialog box, click Utilities.

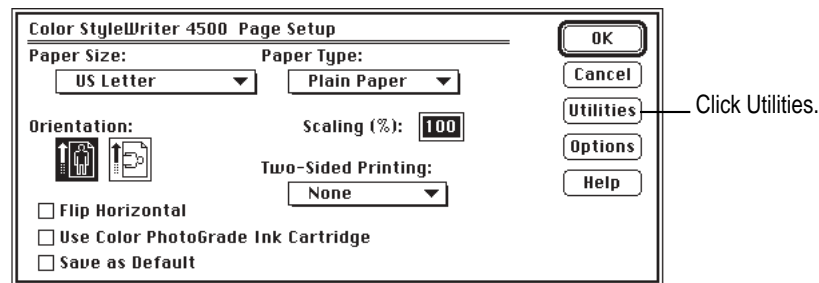

- 5 In the dialog box that appears, find Align Print Cartridges and click Start.

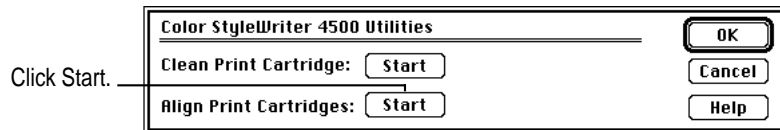

- 6 Read the message that appears, and click Align.

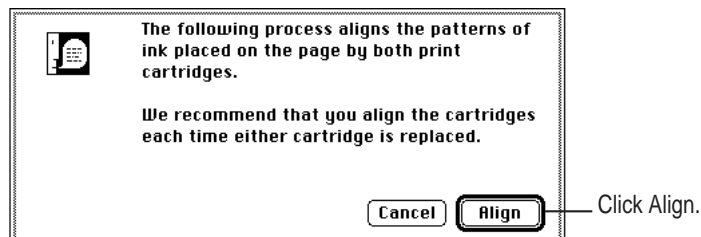

**7 Examine the patterns that appear on the printed page.**

From among the sets of parallel lines, choose the horizontal set and the vertical set for which the black and magenta lines are most closely aligned.

**IMPORTANT** If you cannot see black lines, make sure you have removed the tape from the black ink cartridge. If you cannot see magenta lines, remove the tape from the color ink cartridge

**8 In the dialog box that appears, click the number and letter corresponding to the best aligned sets, and click OK.**

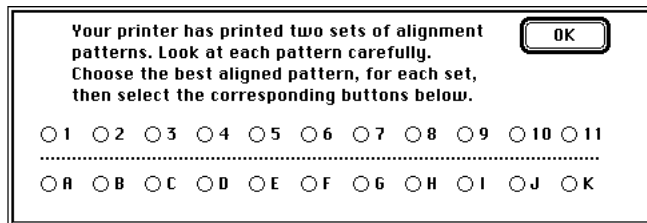

The printer prints a second page, containing a square and a cross, for you to verify that the alignment is acceptable.

**9 If the patterns on the second printed page are acceptable, click OK.**

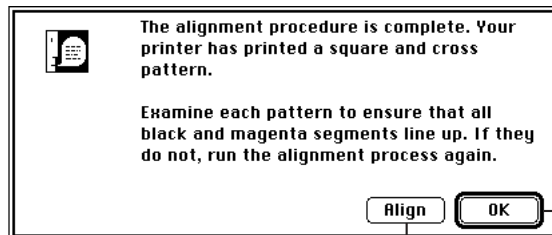

If the square and cross are properly aligned, click OK.

To repeat the process, click Align.

**10 Click OK in the remaining dialog boxes.**

You have finished aligning the ink cartridges in your printer.

## Printing the sample page

To see what your printer can do, print the demonstration page.

- 1 **Make sure the printer and computer are turned on.**
- 2 **Press and hold down the resume button for three seconds and release it.**

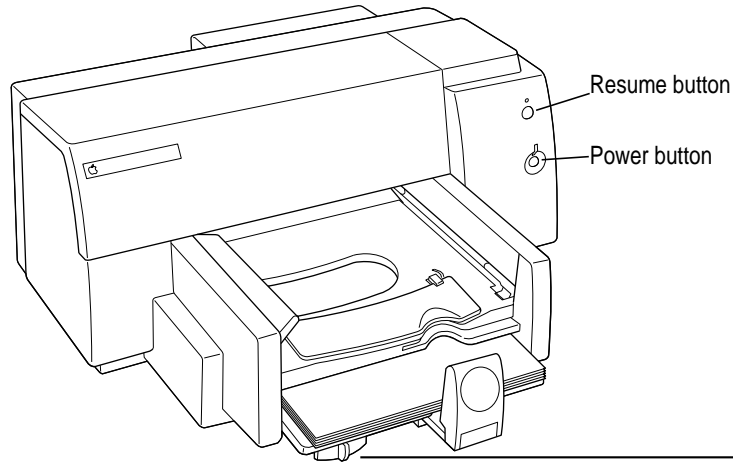

Make sure the paper selection lever is all the way to the left.

The printer prints the sample page, your first full-color document from your new printer.



**Note** You do not need to print this page every time you use the printer.

## Using onscreen help

The CSW 4000 Series Printer Guide is a valuable source of information about your printer and printer software. The Guide menu is identified by a question mark (?) in the upper-right corner of the screen.

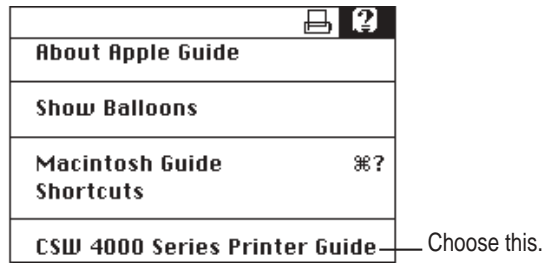

To open CSW 4000 Series Printer Guide, make sure you are in the Finder. Then choose CSW Guide from the Guide (?) menu at the top of your screen.

Macintosh (or Mac OS) Guide also contains general information about printing, as well as other information about using your computer. Macintosh Guide is available while you're in the Finder.

CSW 4000 Series Printer Guide provides onscreen help on how to use your printer.

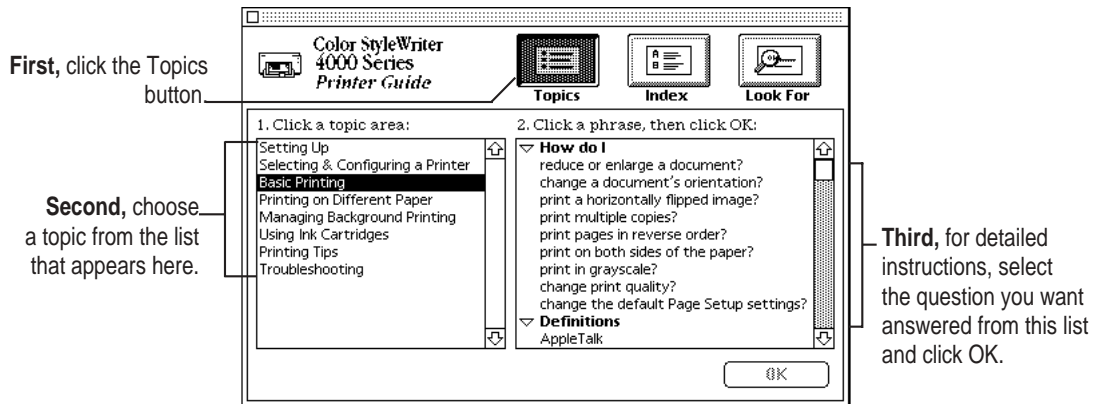



## Tips for using CSW 4000 Series Printer Guide

### When you can't find the information you need

- In searching for help topics, use all three buttons at the top of Guide's initial window: Topics, Index, and Look For.
- If you're in a series of steps and want to return to the list of help topics, click the button marked Topics in the Guide window.

### When you can't see what's behind the Guide window

Guide windows stay in front of other windows on the screen so that your instructions are never covered.

- Drag a Guide window by its title bar to move it out of the way.
- Click the zoom box once to shrink a guide window. (To expand the window, click the zoom box a second time.)

### When you need more information about an instruction or term

- Click the "Huh?" button if it is available.
- If an unfamiliar word is underlined, click it to get a definition.

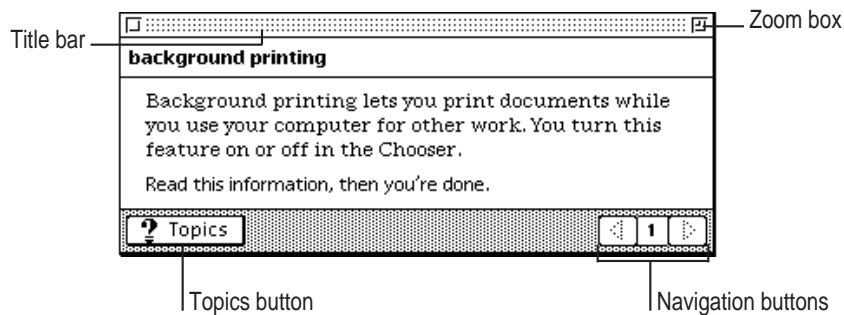

## Using the electronic user's manual

This setup manual also appears as Chapter 1 in an electronic user's manual, along with the complete reference information about your printer. The electronic manual, in Adobe Portable Document Format (PDF) is available on the Apple Printer software Collection CD-ROM.

- 1** On the CD-ROM, open the Printer Software folder and find the Electronic Manual folder.
- 2** Drag the Electronic Manual folder to your hard drive.
- 3** Double-click the Electronic Manual folder to open it.
- 4** Double-click the Installer

Follow the instructions on the screen to install Adobe Acrobat™ Reader.

- 5** When installation is complete, double-click the CSW Manual.pdf file to open it.

Now you can read the manual on your computer screen.

### Tips for finding and printing information with Acrobat Reader

Adobe Acrobat Reader has features that give you fast, easy access to information.

- For help using the Acrobat Reader, choose Acrobat Reader Help from the Help (ⓧ) menu at the top of your screen. The Adobe Acrobat Reader Online Guide appears.
- Print only specific sections of the manual that contain information you need. Printing an entire PDF file can be a time-consuming task and can use large amounts of ink and paper unnecessarily.

# 2

## Printing



This chapter explains how to use the Color StyleWriter 4500 for everyday tasks. Before you follow the instructions in this chapter, make sure the printer is set up and working, as described in Chapter 1.

### Planning documents with the Color StyleWriter 4500 in mind

Many printer options affect how much can fit on a page. Before you spend a lot of time laying out a document, set it up as you plan to print it:

**1 Select the printer you plan to use.**

If the Color StyleWriter 4500 is your only printer, and you followed the setup instructions in Chapter 1, you have selected your printer. If you have access to more than one printer, see “Switching Between Printers,” later in this chapter.

**2 With the document active on your computer screen, choose Page Setup from the File menu and select the options you like.**

The key areas that affect page layout are paper size, type, and orientation. When you’ve finished setting your options, click the OK button to return to your document. You can now format it as you like. Since you’ve already set your printing options, the document will print as you see it on your screen.

## Printing a document

The next two sections explain the different ways you can print a document:

- **Quick instructions for printing standard documents.** To print documents that don't require any special options, see this section. (The section describes what a "standard document" is.)
- **Detailed instructions for printing other documents.** To print documents that require any of the nonstandard options, see this section.

### Quick instructions for printing standard documents

To print a standard document, follow the instructions in this section:

- standard paper size, US Letter (8.5" by 11" in the United States)
- plain paper
- portrait page orientation (so when you look at the printed page, it is longer than it is wide)
- no special effects and normal print quality

Assuming you have already selected the printer in the Chooser as described in Chapter 1, and that the printer is filled with standard paper, you need only follow these steps:

- 1 While the document is in an active window, choose the Print command from the File menu.**

The Print dialog box opens on your screen.

- 2 Make sure the printer is turned on (the green power light glows).**
- 3 Click the Print button.**

After a few moments, the document starts to print. If background printing is turned on, you can continue working while the document is printing. You can also monitor and control the documents that are waiting to print. (See "Printing While You Use Your Computer" and "Monitoring and Controlling Background Printing," later in this chapter.)

## Detailed instructions for printing documents

If your document is not standard, follow these steps:

- 1 **If you haven't already selected the Color StyleWriter 4500 in the Chooser, do so now.**

You already selected the Color StyleWriter 4500 in Chapter 1, and if it's the only printer you ever use, you won't need to do it again. If you do need to switch, see "Switching Between Printers," later in this chapter.

- 2 **Load the paper, envelopes, or other materials into the printer, as described in Chapter 1.**

Remember to adjust the external paper selector before filling the sheet feeder.

- 3 **While the document is active on your screen, choose Page Setup from the File menu and make adjustments in the dialog box that opens.**

If the default settings shown here are satisfactory, you can skip this step.

To indicate the size and type of paper in the paper tray, use these pop-up menus.

To print with a PhotoGrade cartridge in the printer, click to put an X in this box. (You may also want to choose Photograde from the Paper Type pop-up menu.)

For manual duplex printing (two-sided), use this pop-up menu.

You can type a number from 25 to 400. Numbers smaller than 100 reduce the image; numbers greater than 100 enlarge it. Changing the size may change the pagination.

Choose the settings you want, then click OK.

For more information about optional features, see "Adjusting Color Options," later in this chapter.

**IMPORTANT** Make sure you correctly indicate the size of the paper, envelopes, or other material you have in the paper tray. If you change the paper size in this dialog box, you might also want to look over your document to see if any of the page breaks have changed. For information on non-standard sizes, see "Defining Your Own Custom Paper Sizes," later in this chapter.

#### 4 Choose Print from the File menu and make adjustments in the dialog box that opens.

The screenshot shows the 'Color StyleWriter 4500' print dialog box. It includes a 'Quality' dropdown menu set to 'Normal', a 'Pages' section with 'All' selected and 'From'/'To' input fields, a 'Copies' spinner set to 1, and checkboxes for 'Print in Grayscale' and 'Print Back to Front'. On the right side, there are buttons for 'Print', 'Cancel', 'Preview', 'Options', and 'Help'. Annotations with lines pointing to these elements provide instructions: 'Best quality takes longer to print. Draft is faster.' points to the Quality dropdown; 'To print color images in black and white and grayscale, click to put an X in this box.' points to the Print in Grayscale checkbox; 'If you want your printed pages to be stacked in the correct order as they come out of the printer, click to put an X in this box.' points to the Print Back to Front checkbox; 'Choose the settings you want, then click Print.' points to the Print button; and 'To see how your page will look when printed, click Preview.' points to the Preview button.

Item in dialog box	What you use it for
Quality	Select which level of quality you want. Generally, the higher the quality, the longer the document will take to print. The Draft option is available only when you use Plain paper or Transparency.
Pages	Indicate how many pages of the document to print. To print the whole document, click All. To print a range of pages, type the beginning and end page numbers.
Copies	Type how many copies of the document you want.

#### 5 Click the Print button.

After a few moments, the document starts to print. If background printing is turned on, you can continue working while the document is printing. You can also monitor and control the documents that are waiting to print. (See “Printing While You Use Your Computer” and “Monitoring and Controlling Background Printing,” later in this chapter.)

## Printing while you use your computer

You can continue to work on your computer while printing on the Color StyleWriter 4500. The feature that gives you this ability is called *background printing*. To turn background printing on or off, follow these steps:

- 1 **Select Chooser from the Apple () menu.**
- 2 **Click the CSW 4000 Series icon in the Chooser.**

If your printer is connected to your computer by a LocalTalk connection kit, click the CSW 4000 Series (AT) icon.

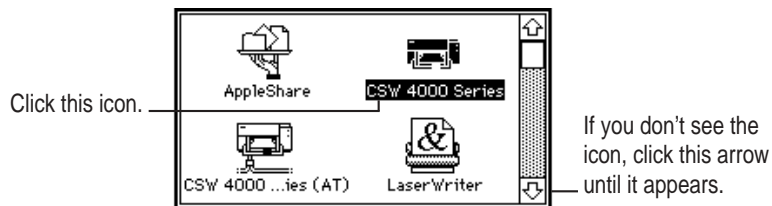

- 3 **Click to turn background printing on or off.**

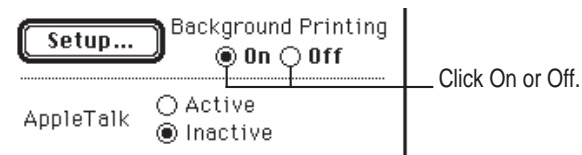

- 4 **Click the close box in the upper-left corner of the Chooser.**

Once background printing is turned on, it is in effect whenever you print, until you turn it off. When you click Print in the Print dialog box, a message appears for a moment to tell you the document is being prepared. Once the message disappears, you can continue other work. Your computer may pause occasionally while it processes the document for printing. See “Monitoring and Controlling Background Printing,” next, for more information.

*Note:* Printing may be slower with background printing on. If you turn background printing off, however, you must wait for printing to finish before you can continue your work. Any time you print with the color PhotoGrade cartridge on PhotoGrade paper, you should turn off background printing.

## Monitoring and controlling background printing

If you are using background printing, you can use the PrintMonitor to check on and control your print requests. (To turn background printing on and off, see “Printing While You Use Your Computer,” earlier in this chapter.)

- 1 While printing is in progress, choose PrintMonitor from the Application menu.

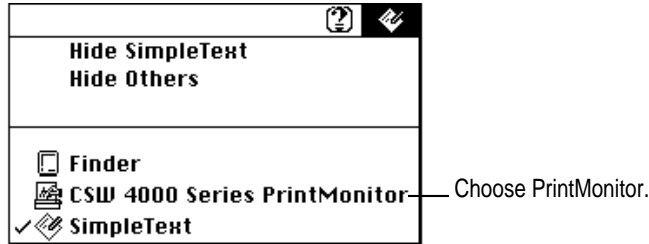

A window opens listing the documents that are printing or waiting to print:

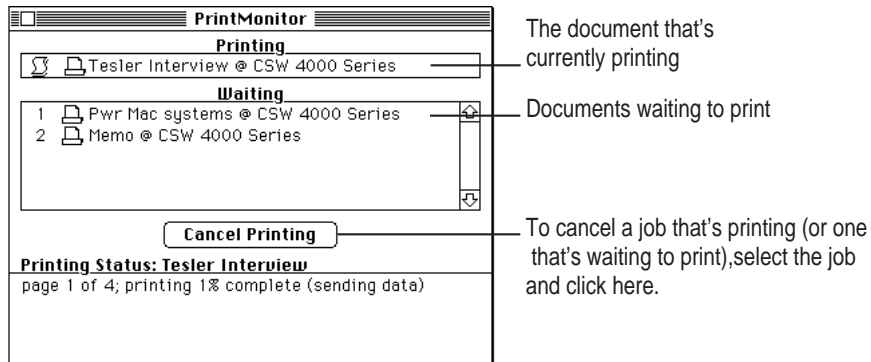

- 2 You can check the activity on your printer and cancel printing if you want to.



## Adjusting color options

To adjust the way colors are printed, follow these steps:

- 1 Choose Print from the File menu.
- 2 In the dialog box that appears, click Options.

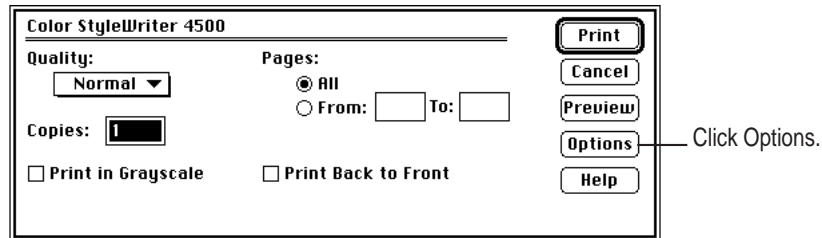

- 3 Select your color options.

Unless you have specific needs, it may be best to leave the settings on Auto.

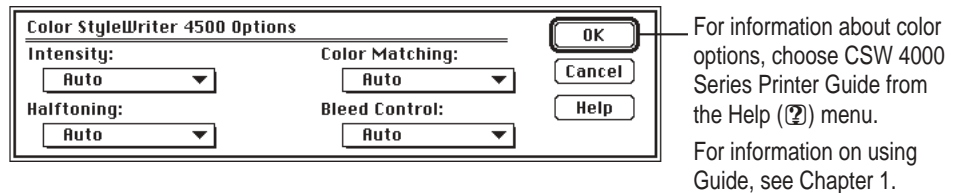

The ColorSync color-matching system makes sure that colors look as consistent as possible no matter what device you use to view them—monitor or printer. In addition, ColorSync helps give you the best possible colors when you export the image to another Mac OS–based computer with ColorSync installed or print it on another color printer.

*Note:* For the best color, you need to choose a specific profile for your monitor. In the ColorSync control panel, choose the D50 profile for your monitor. If there is no D50 available for your monitor, choose Apple Multiple Scan 17 – D50. The D50 profile gives you better colors.

For more information on ColorSync, see Appendix C.

## Printing a photograph

You can print exceptional quality photographic or other color images, using the color PhotoGrade ink cartridge.

- Use the color and color PhotoGrade cartridges to print color and black-and-white photographs or pictures with vivid colors.
- Use the color and black cartridges for black text, documents that are mainly text, banners, and pictures other than photographs.

### 1 Put paper in the lower paper tray, print side down (as usual).

If you're using Apple Color Ink–Jet Color PhotoGrade paper, the package tells you which side to print on. You can use plain paper to print photographs. For best results, use PhotoGrade paper.

**IMPORTANT** Before you print using the color PhotoGrade ink cartridge and color PhotoGrade paper, be sure to turn off background printing. With background printing on, the printer experiences small delays when the computer is busy with something else. The resulting print quality may not be the best you can get from your Color StyleWriter 4500.

### 2 Turn on the printer.

The green power light should glow.



- 6 Slide the color PhotoGrade ink cartridge down into the carrier, and press it into place.

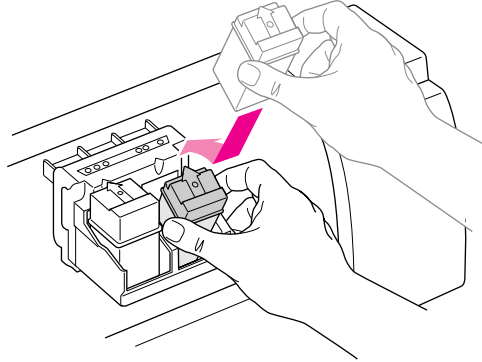

Press the cartridge all the way into the carrier.

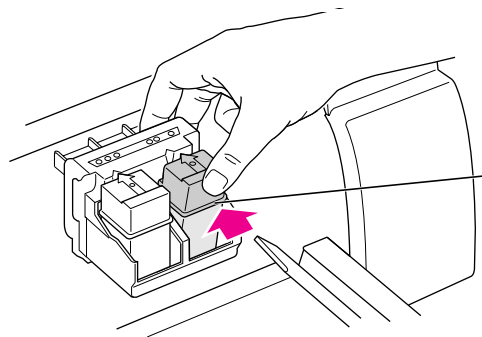

**Note:** The color PhotoGrade ink cartridge includes specially formulated black and color inks for photorealistic printing.

- 7 Close the printer's cover.

The carrier returns to its home position on the right side of the printer, and the resume light stops flashing.

**8 Choose Page Setup from the File menu.**

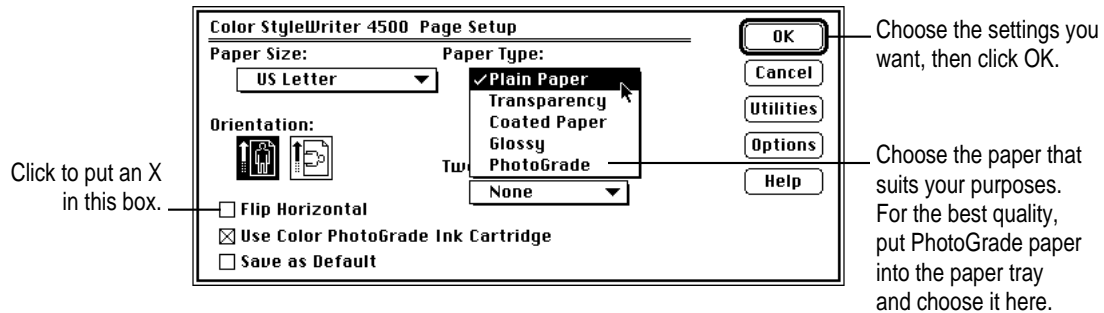

**9 Choose Print from the File menu.**

**10 In the dialog box that appears, click Print from the File menu.**

The document containing the photographs begins to print. It may take several minutes before you can see the results.

**When you're done printing photographs**

Take the time to reset the printer for normal printing. Here are some settings to remember:

- Take the color PhotoGrade ink cartridge out of the printer, put it into the storage case, and put the black ink cartridge back into the printer.
- In the Page Setup dialog box, change Paper Type back to Plain Paper (if that's what you plan to use next). Click the Use Color PhotoGrade Cartridge checkbox to remove the X.
- Remove any special paper from the lower paper tray, and replace it with plain paper.

## Printing a banner

For the best results, use Apple Color Ink–Jet Banner Paper. If you use continuous computer paper or Z-fold paper instead, 20-pound paper is best.

- 1 Choose Page Setup from the File menu.
- 2 In the Page Setup dialog box, choose either Banner US Letter or Banner A4 from the Paper Size pop-up menu.

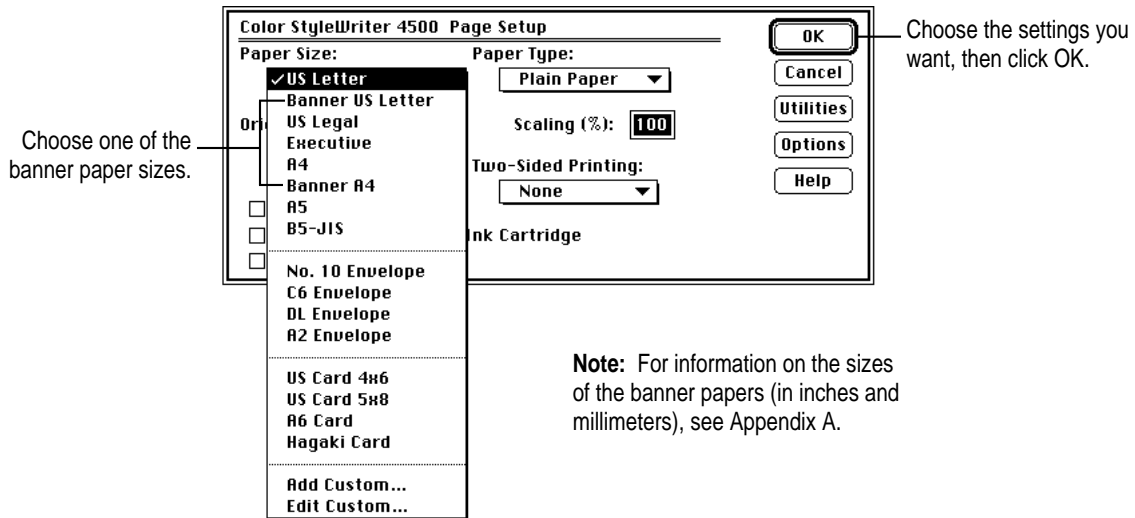

- 3 Slide the paper selection lever to the right until it clicks into place.**

An icon on the lever indicates that this is the setting for banner paper.

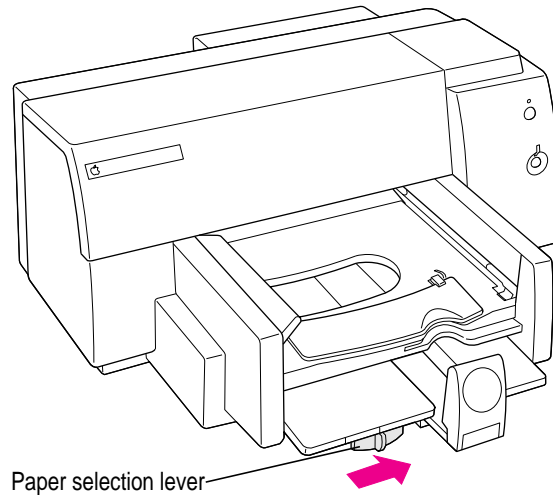

- 4 Remove all paper from the lower tray.**

- 5 Flip up the banner support in the upper tray.**

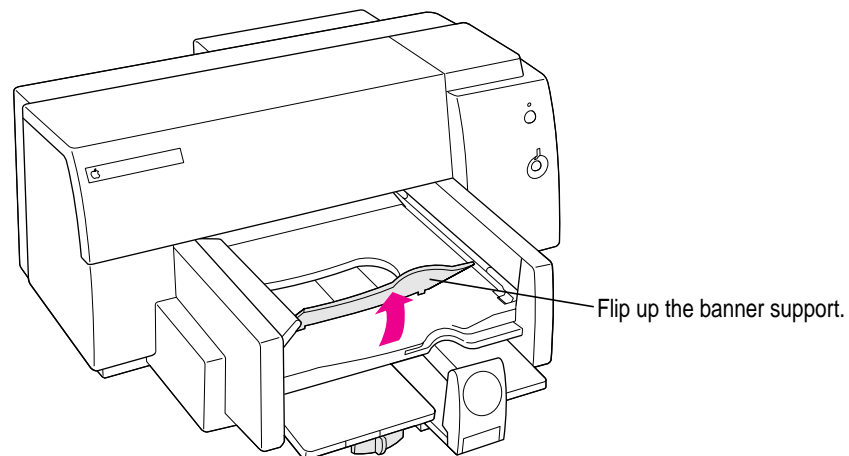

- 6 Estimate how many sheets your banner needs to print.**

Using the application that created the banner, you should be able to tell whether the banner will cover three sheets or four sheets, for example. The printer prints a maximum of 20 sheets in one banner.

- 7** From a stack of Z-fold banner paper, tear off at least one sheet more than you need to print the banner.
- 8** Tear off the perforated strips, if any, and then unfold and refold the stack to make sure pages don't stick together.

Put this edge into the paper tray first, at the top of the stack

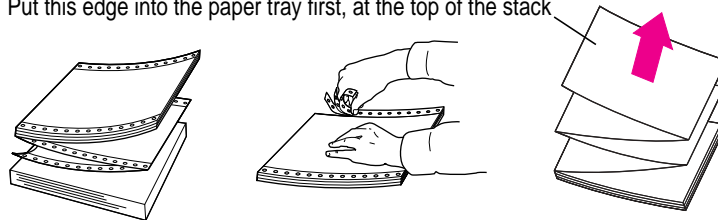

- 9** Put the paper in the lower paper tray, with a torn edge at the top of the stack, facing lengthwise into the printer.

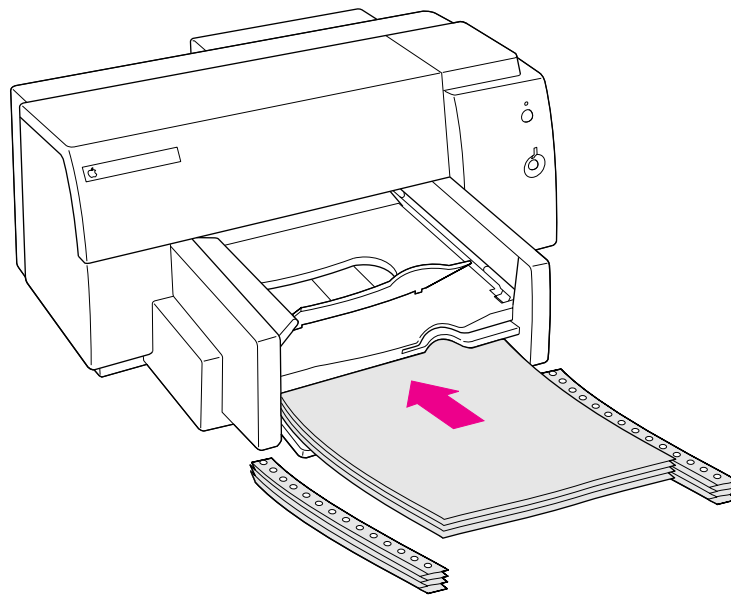

- 10** Slide the paper adjusters so they touch the edges of the stack of paper.



- 11 **Make sure the banner document is the active window on the screen, and choose Print from the File menu.**
- 12 **In the dialog box that appears, click Print.**
- 13 **When printing stops, press the Resume button as many times as necessary to advance the remaining banner paper out of the printer.**

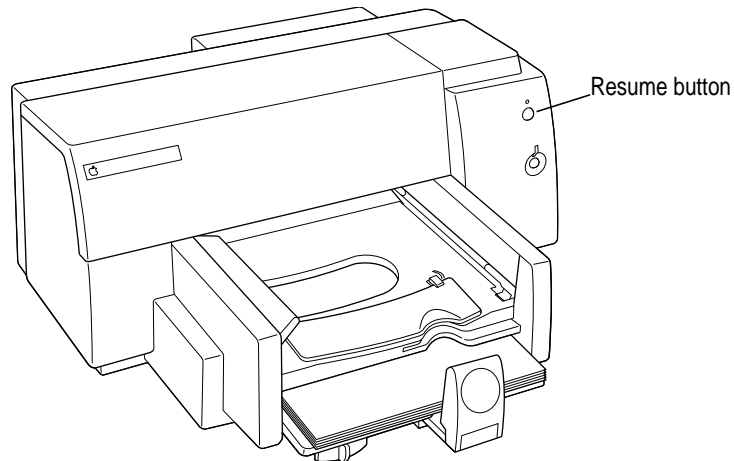

### When you're done printing banners

Take the time to reset the printer for normal printing. Here are some steps to remember:

- In the Page Setup dialog box, select the Paper Size appropriate for the document you want to print next.
- Slide the paper selection lever to the left. (The lever is located underneath the left corner of the lower paper tray.)
- Lower the banner support in the upper tray.
- Put some paper into the lower paper tray.

## Printing envelopes

If you're printing a single envelope, use the single-envelope slot (and leave the paper in the paper tray). If you're printing a stack of envelopes, use the paper tray

### Notes about envelopes

See the instructions that came with the applications you use to see if they offer special, easy ways to format and print envelopes. If not, choose the envelope size you're using in the Page Setup dialog box and format the envelope text as you like.

**IMPORTANT** The Color StyleWriter 4500 cannot print flush with the left edge, so return addresses may print closer to the center than you like. To avoid the problem, use envelopes preprinted with your return address, or put the address on a label or a rubber stamp.

### Single business-size envelopes

- 1 Choose Page Setup from the File menu.
- 2 In the Page Setup dialog box, choose either No. 10 Envelope or DL Envelope from the Paper Size pop-up menu.

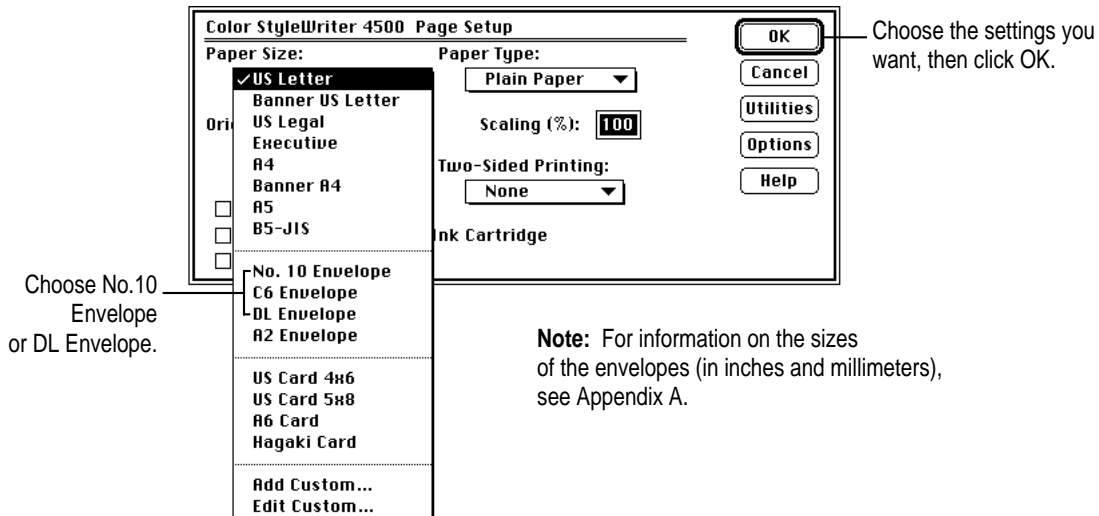

- 3 Slide an envelope into the single-envelope slot until it stops.

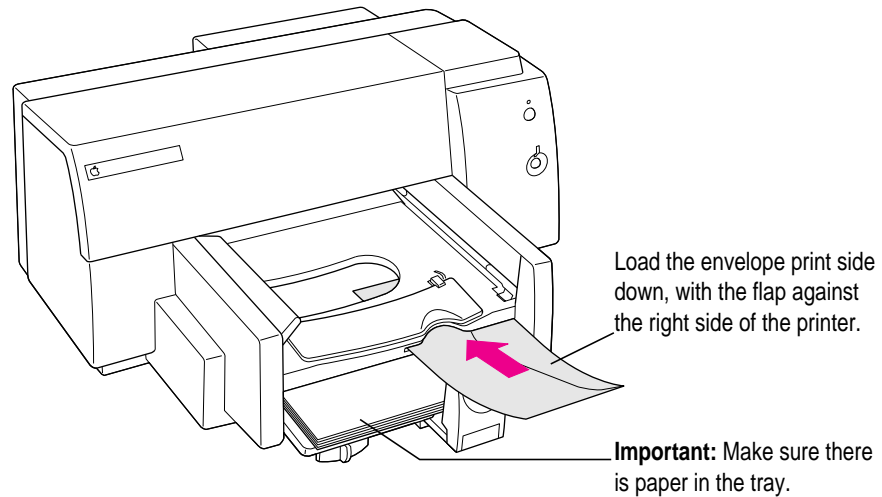

- 4 Choose Print from the File menu.

If you are using an application that includes settings for printing envelopes, follow the application's instructions for setting up the address and placing the envelope in the printer.

- 5 In the dialog box that appears, click Print.

## A stack of envelopes

- 1 Choose Page Setup from the File menu.
- 2 In the Page Setup dialog box, choose the envelope you're printing from the Paper Size pop-up menu.

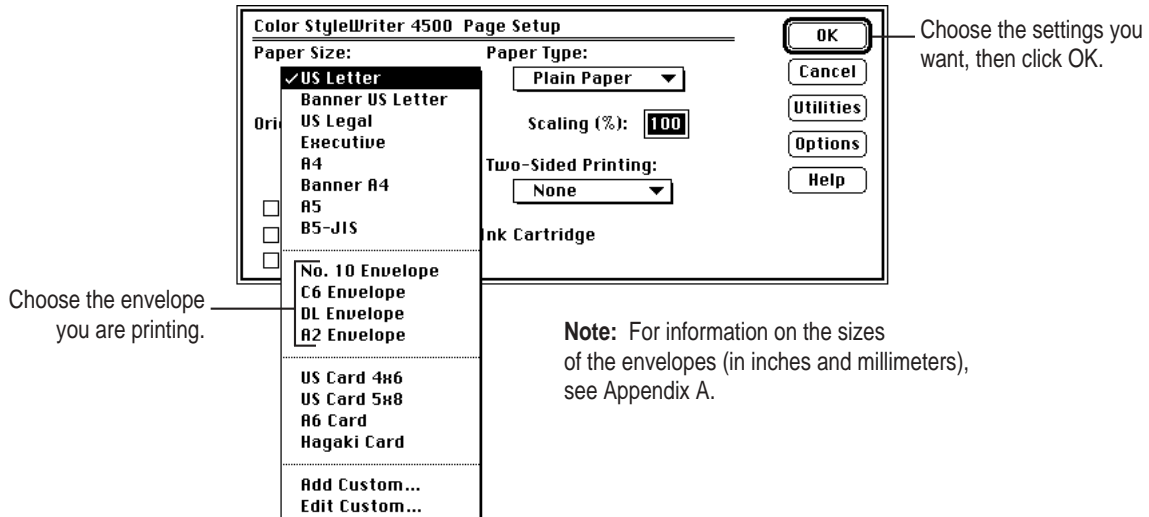

- 3 Slide the paper adjusters out as far as you can.

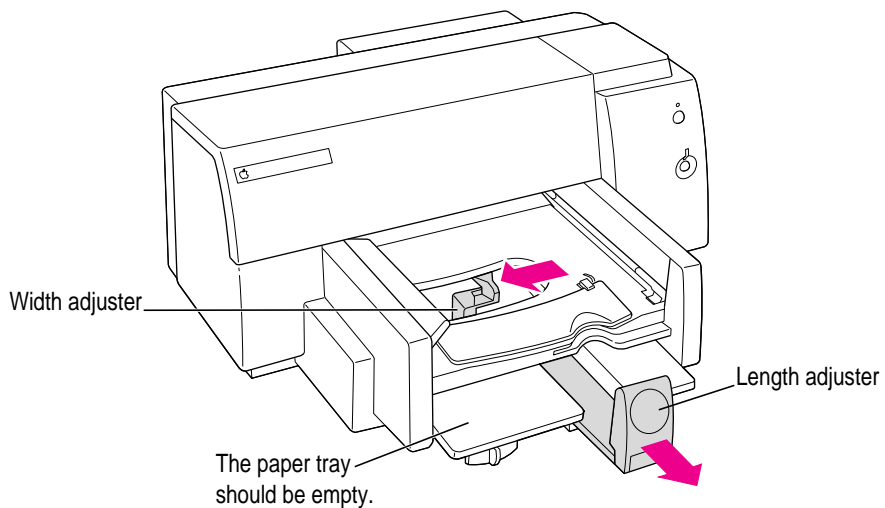

**4 Put a stack of up to 20 envelopes in the printer.**

If the envelopes are thick, reduce the number in the stack.

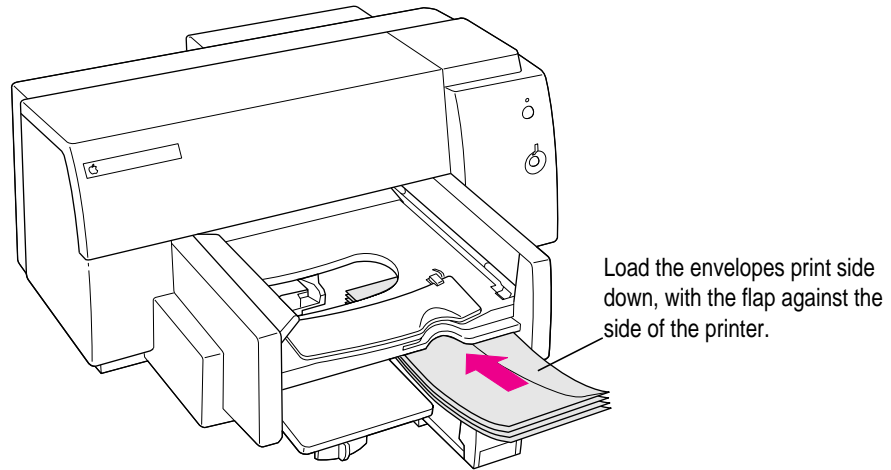

**5 Slide the paper adjusters in so they touch the edges of the stack of envelopes.**

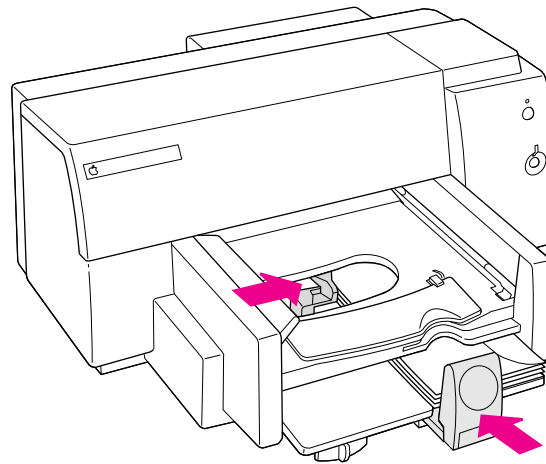

If you're printing small, invitation-size envelopes (such as A2 or C6), you may have to lower the handle on the length adjuster so you can slide it far enough under the upper paper tray.

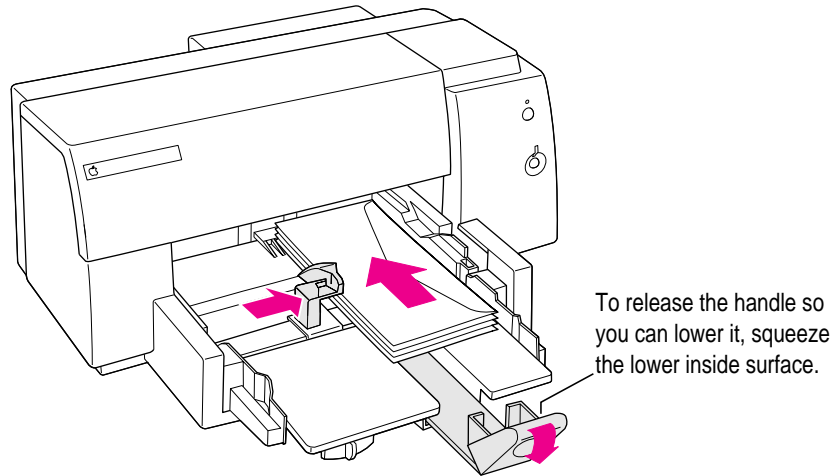

**6 Choose Print from the File menu.**

If you are using an application that includes settings for printing envelopes, follow the application's instructions for setting up the address and placing the envelope in the printer.

**7 In the dialog box that appears, click Print.**

**When you're done printing envelopes**

Take the time to reset the printer for normal printing. Here are some steps to remember:

- In the Page Setup dialog box, select the Paper Size appropriate for the document you want to print next.
- Remove any unused envelopes and make sure there is paper in the lower paper tray.

## Printing transparencies

For best results, use Apple Color Ink–Jet Transparency Film or transparencies designed for ink–jet printers.

- 1 Choose Page Setup from the File menu.
- 2 In the Page Setup dialog box, choose Transparency from the Paper Type pop-up menu.

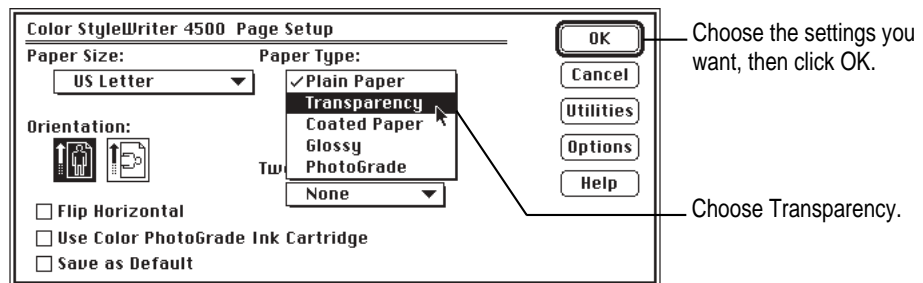

- 3 Choose Print from the File menu.
- 4 In the Print dialog box that appears, choose Best from the Quality pop-up menu.

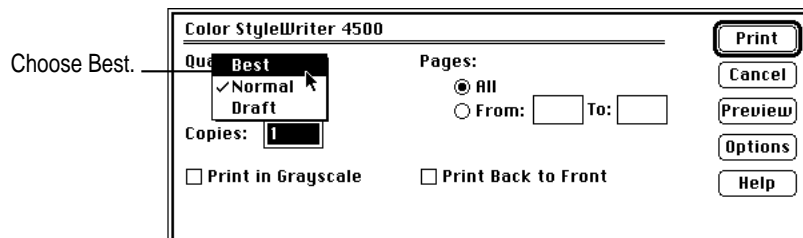

- 5 **Insert the transparencies into the paper tray, shiny side down, with the joined edge into the paper tray first.**

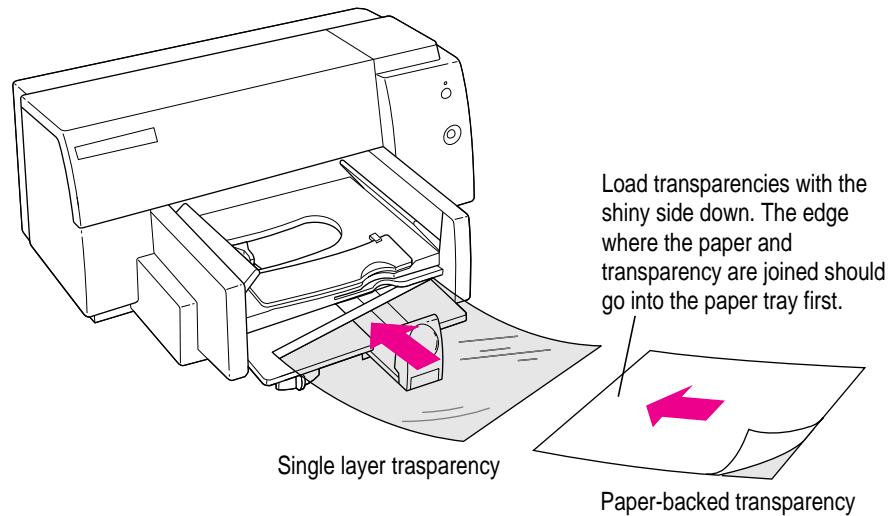

- 6 **Slide the paper adjusters in so they touch the edges of the stack.**
- 7 **Choose Print from the File menu.**
- 8 **In the dialog box that appears, click Print.**

In printing transparencies, the printer uses more ink, puts it on the transparency surface more slowly, and allows more time for inks to dry between sheets. For these reasons, transparencies take a while to print.

### **When you're done printing transparencies**

Take the time to reset the printer for normal printing. Here are some steps to remember:

- In the Page Setup dialog box, select the Paper Type appropriate for the document you want to print next.
- Remove any unused transparencies and put some paper into the lower paper tray.
- Next time you print, remember to change the print quality back to Normal (or whatever is appropriate) in the Print dialog box.



## Printing labels

For best results, use labels designed for ink-jet printers.

- 1 Choose Page Setup from the File menu.
- 2 In the Page Setup dialog box, choose US Letter or A4 from the Paper Size popup menu, and choose Plain Paper from the Paper Type pop-up menu.

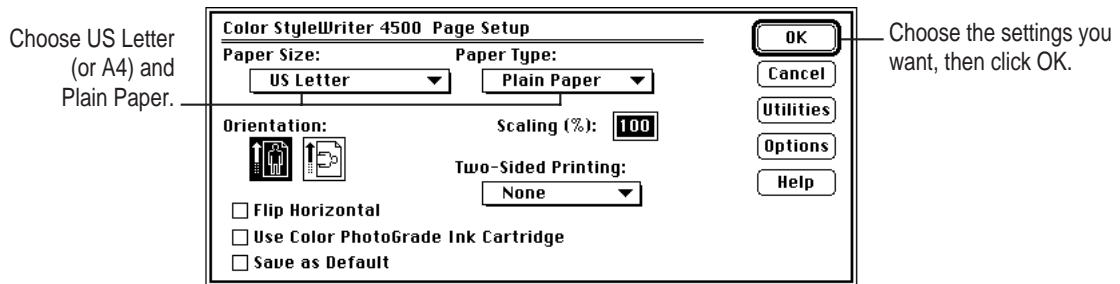

- 3 Choose Print from the File menu.
- 4 In the Print dialog box that appears, choose Normal from the Quality pop-up menu.

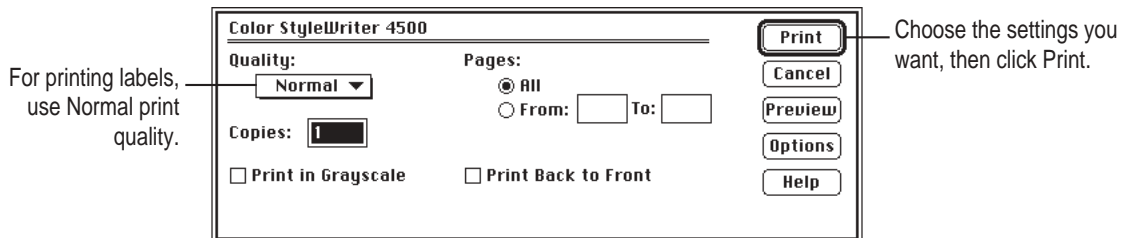

- 5 Fan the edges of the label sheets to make sure they are separated.
- 6 Insert into the paper tray sheets of labels, face-down, on top of about 5 sheets of plain paper that's the same size.

You can insert up to 25 sheets of labels.

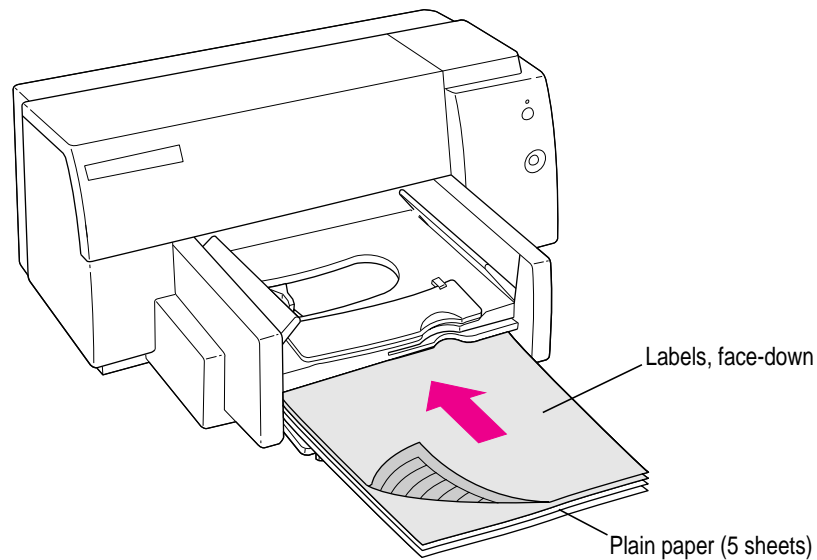

- 7 Slide the paper adjusters in so they touch the edges of the stack.
- 8 Choose Print from the File menu.
- 9 In the dialog box that appears, click Print.

### When you're done printing labels

If you expect to print on plain paper next, you can leave the print settings as they are.

## Printing index cards and postcards

You can use the Color StyleWriter 4500 to print on index cards and postcards.

- 1 Choose Page Setup from the File menu.
- 2 In the Page Setup dialog box, choose the card size you want from the Paper Size pop-up menu, and choose Plain Paper from the Paper Type pop-up menu.

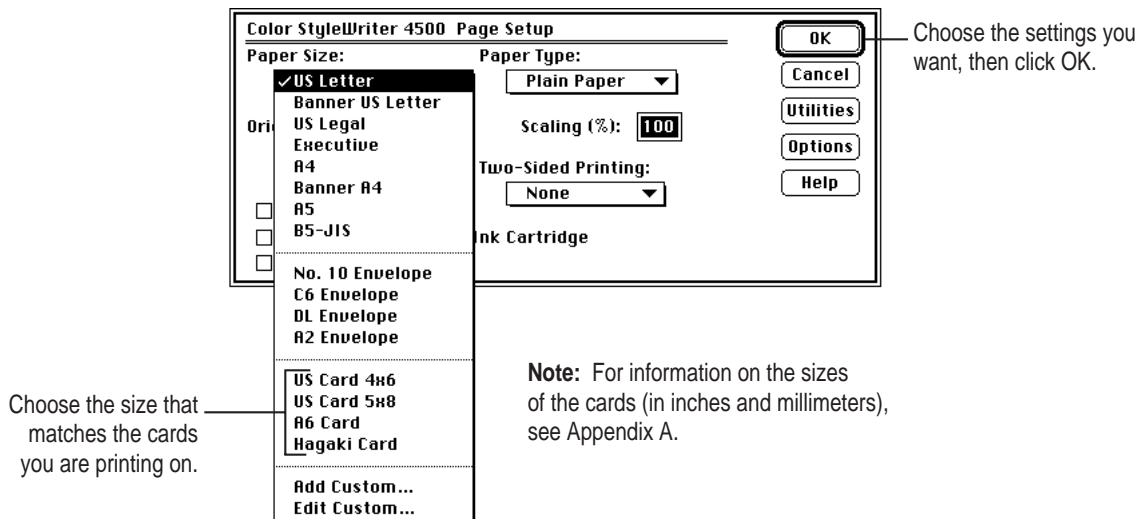

- 3 Remove the upper tray and raise the card guide.

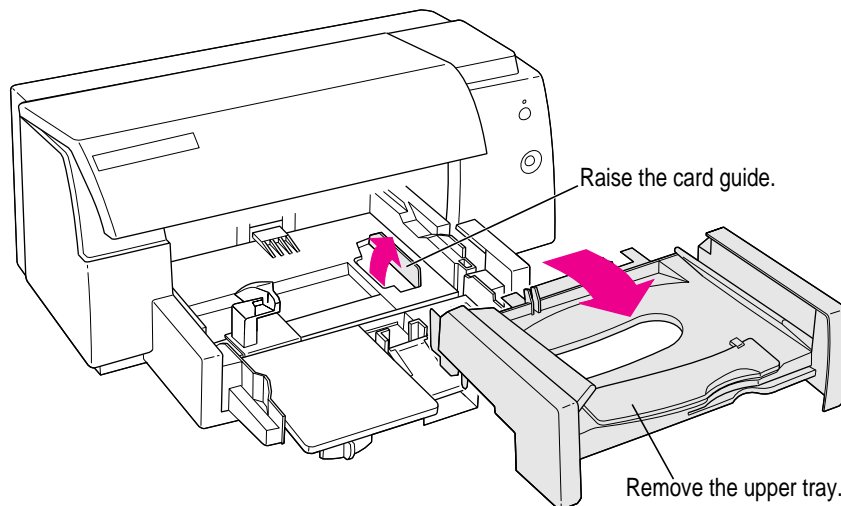

- 4 Place a stack of up to 30 cards in the lower paper tray, resting against the raised card guide.
- 5 Lower the handle on the paper length adjuster.

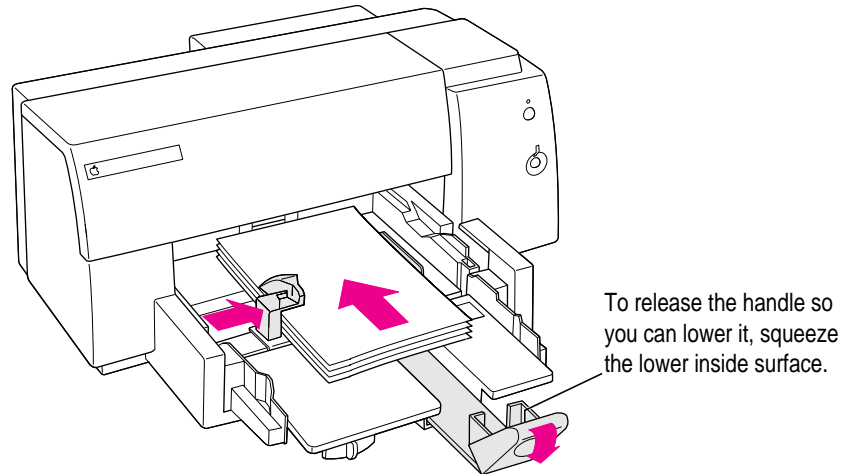

- 6 Slide the paper adjusters in so they touch the edges of the stack.

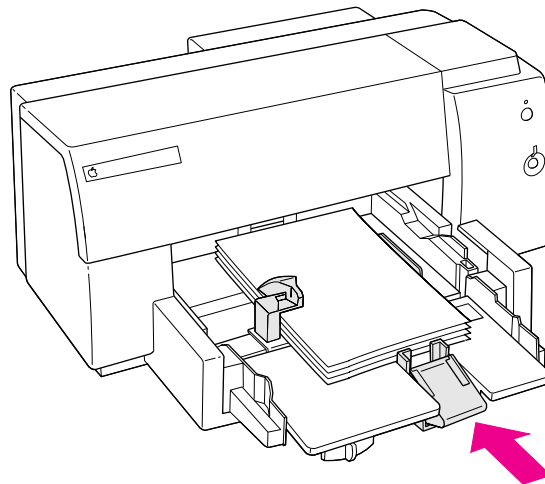

**7 Replace the upper tray and raise the card guide.**

You may need to lift the printer cover for easy access.

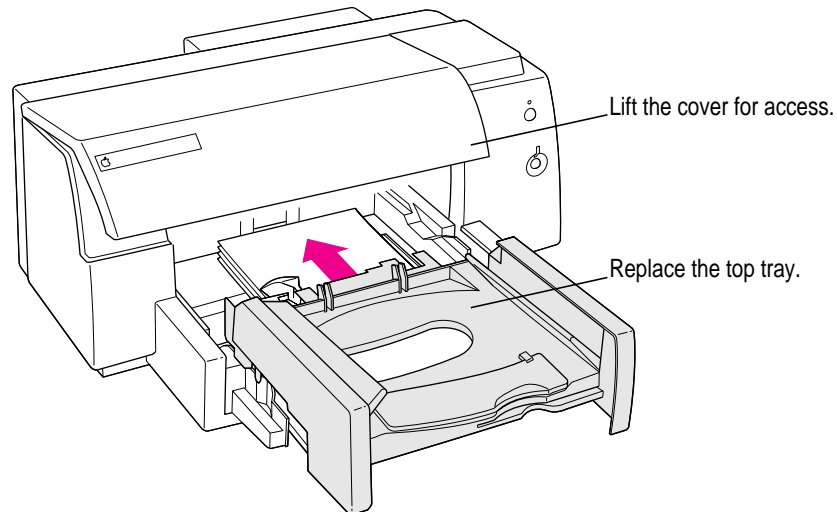

**8 Choose Print from the File menu.**

**When you're done printing index cards or postcards**

Take the time to reset the printer for normal printing. Here are some steps to remember:

- In the Page Setup dialog box, select the Paper Size appropriate for the document you want to print next.
- Remove the top tray, then remove any unused cards and lower the card guide.
- Replace the top tray and make sure there is paper in the lower paper tray.
- Raise the paper adjuster handle back to its vertical position.

## Manual duplex printing (two-sided)

To conserve paper, you can print on both sides, putting the paper through the printer twice. The first time through, the printer prints odd-numbered pages; the second time through, it prints even-numbered pages.

*Note:* Use 28-pound or heavier paper for manual duplex printing. If you use a lighter paper, the ink may bleed through the paper.

**1 Put paper in the lower paper tray.**

Remove any paper from the upper tray.

**2 Choose Page Setup from the File menu.**

**3 Choose Book or Tablet from the Two-Sided Printing pop-up menu, and click OK.**

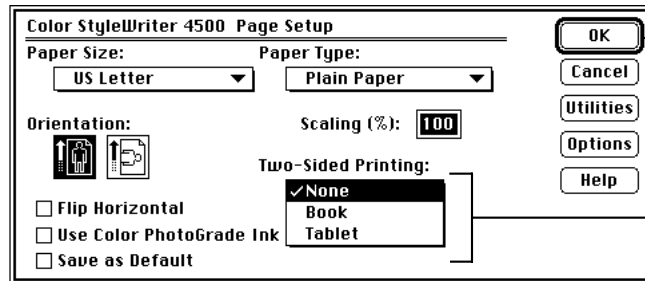

Choose the settings you want, then click OK.

**Book** prints the pages so they can be bound on the left, as a book.

**Tablet** prints the pages so they can be bound at the top, as a tablet.

**4 Choose Print from the File menu.**

The printer automatically prints the odd-numbered pages and delivers them in the upper paper tray.

**5 Following instructions on the screen to bring PrintMonitor to the front, choose PrintMonitor from the Application menu.**

- 6** Following instructions on your screen, put the stack of printed pages back into the lower paper tray.

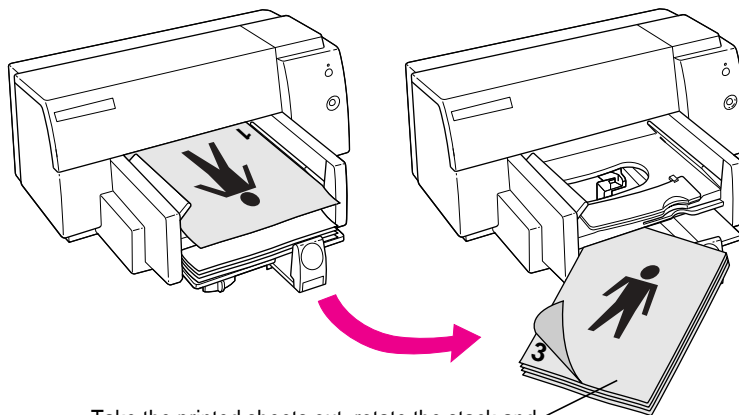
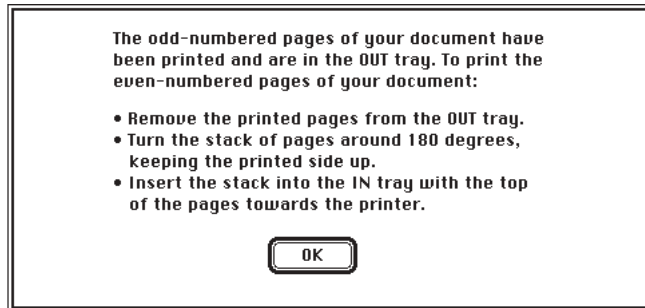

Take the printed sheets out, rotate the stack and insert it into the lower paper tray, with the printed side up. The second side will be printed according to what you choose (Book or Tablet) in step 3.

- 7** When the paper is ready, click OK.

**When you're done with manual duplex printing (two-sided)**

Take the time to reset the printer for normal printing. In the Page Setup dialog box, choose None from the Two-Sided Printing pop-up menu.

## Printing a flipped document

You can flip a document, reversing text and pictures so they are correct when you transfer the image to another surface (such as a T-shirt). Flipping can also be useful when you print transparencies. (You can write on the transparency without smearing the ink printed on the reverse side.)

- 1 Put paper in the lower paper tray, print side down (as usual).

If you're using transparencies, put them in rough side down.

- 2 Choose Page Setup from the File menu.
- 3 Click Flip Horizontal and click OK.

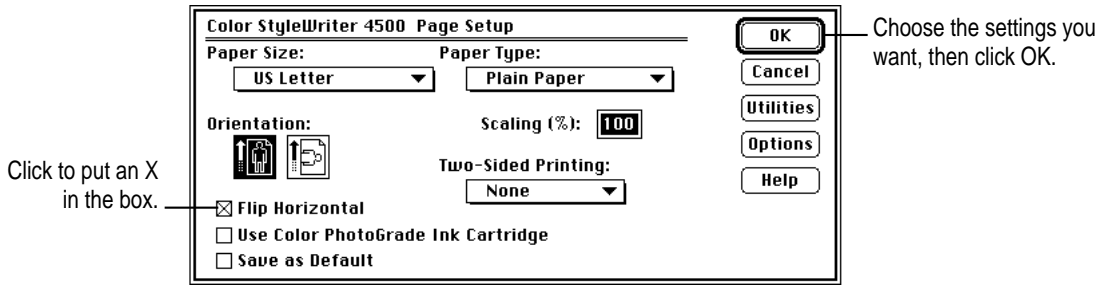



**4** Choose Print from the File menu.

**5** In the dialog box that appears, click Print.

The text and pictures print backwards. To see the reverse image, hold the page up to a mirror.

### **When you're done printing flipped documents**

Take the time to reset the printer for normal printing. Here are some steps to remember:

- In the Page Setup dialog box, click Flip Horizontal to remove the X from the checkbox.
- If you used transparencies or special paper, replace it with standard paper in the lower paper tray.

## Defining your own custom paper sizes

Occasionally, you may want to print on paper whose size does not appear in the Paper Size menu on the Page Setup dialog box. If the size of the paper falls within these ranges, you can use it:

**Width:** 5 to 8.5 inches

**Length:** 5.83 to 14 inches

To print on the nonstandard paper, follow these steps:

- 1 Put the paper lengthwise into the lower paper tray.**

For easier access, you can remove the upper paper tray, and then put it back when the paper is in place.

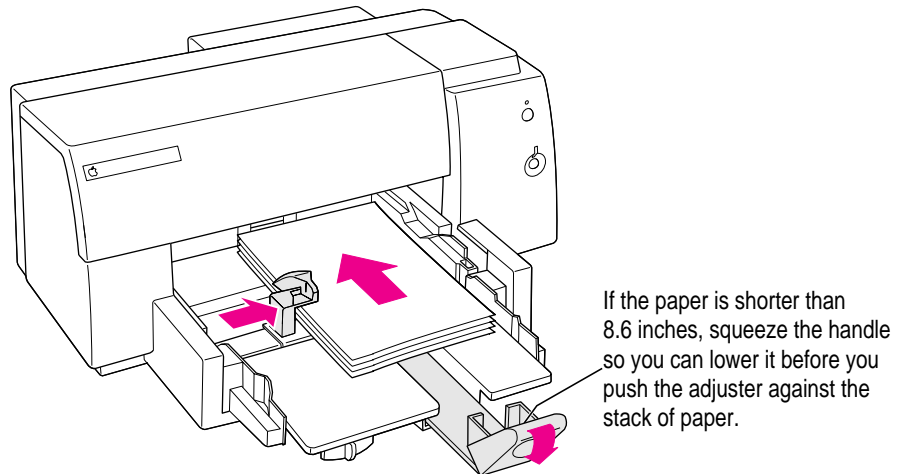

**2** Choose Page Setup from the File menu.

**3** Choose Add Custom from the Paper Size pop-up menu.

**4** In the dialog box that appears, type the appropriate information and click OK.

Specify the size in inches or centimeters.

If you are printing nonstandard envelopes, click to put an X here.

Please enter your custom media size:

Name:

Inches      Width:       Height:

Centimeters

Envelope

Give the custom size a name.

Type the width and height.

When you're ready, click OK.

**5** Choose Print from the File menu.



# 3

## Tips on Paper, Quality, Speed, and Cost



This chapter explains how to use different materials and printing options to meet your needs.

### Choosing print materials

Here are some tips on when and how to use different print materials.

#### Plain paper

Use plain paper for everyday printing.

- Print quality may vary depending on the manufacturer of the paper. If you're not happy with one kind of paper, try a different brand. For consistent results, use one of the special papers designed for the Color StyleWriter 4500 printer.
- You can use any plain paper, including plain copier paper. Paper weight can range from 16 to 36 pounds, though 20-pound paper is recommended.
- Don't use erasable typing paper, damaged or wrinkled paper, stapled paper, or multipart forms ("carbonless carbons").
- Plain paper almost always has one side that is better for printing than the other. See the package label to determine which side is better, and load that side face down in the lower paper tray.

### Apple Color Ink–Jet Premium Coated Paper

This bright white coated paper is great for creating high-quality presentations, newsletters, and reports.

- Use only coated paper designed for use with the Color StyleWriter 4500.
- One side of the paper is a little whiter than the other and is better for printing. See the package label on the coated paper to determine which side is better, and load that side face down in the lower paper tray.

### Apple Color Ink–Jet Glossy Paper

This glossy, heavyweight paper produces vibrant, permanent color images.

- Use only glossy paper designed for use with the Color StyleWriter 4500.
- When loading a stack of glossy paper into the paper tray, put a single sheet of plain paper at the bottom of the stack to prevent misfeeding.

### Apple Color Ink–Jet PhotoGrade Paper

Use this heavyweight, photo-quality paper together with the color Photograde ink cartridge for printing photorealistic images.

- Use only PhotoGrade paper designed for use with the Color StyleWriter 4500.
- Load the PhotoGrade paper so that the shiny side is face down in the lower paper tray.

## Apple Color Ink–Jet Banner Paper

Use this paper to print a continuous document that contains pages strung together—for example, a birthday greeting.

- Use only banner paper designed for use with the Color StyleWriter 4500.
- When loading a stack of banner paper into the paper tray, make sure the torn edge at the top of the stack goes into the paper tray first.

## Apple Color Ink–Jet Transparency Film

This fast-drying, smudge-proof transparency film is great overhead presentations.

- Use only transparencies designed for use with the Color StyleWriter 4500. These special transparencies may have a sheet of paper attached to them or a strip of tape at one end; leave the paper and the tape attached until after printing.
- Load the transparencies so that the paper backing or the tape strip is face up in the lower paper tray and the edge where the paper and film are joined or the taped edge goes into the tray first.

## Labels

Use labels for addressing envelopes and other purposes.

- Use only labels designed for use with ink jet printers.
- Load the labels face down in the lower paper tray. Put about 5 sheets of plain paper under the stack of labels.

## Index cards and postcards

Use index card or postcard stock when you want to print small messages, send greetings, post information on bulletin boards.

- Load the cards so that the side you want to print on is face down in the lower paper tray.

## Materials you can print on

Here are details about the kinds of materials you can use in your Color StyleWriter 4500 printer.

Print material	Special instructions
Plain paper	<ul style="list-style-type: none"><li>■ Use 16- to 36-pound paper.</li></ul>
Coated paper	<ul style="list-style-type: none"><li>■ Use only paper designed for this printer.</li><li>■ The whiter side should face down.</li></ul>
Index cards	<ul style="list-style-type: none"><li>■ The print side should face down.</li></ul>
Glossy paper	<ul style="list-style-type: none"><li>■ Use only paper designed for this printer.</li><li>■ The shinier side should face down.</li></ul>
Color PhotoGrade paper	<ul style="list-style-type: none"><li>■ Use only paper designed for this printer.</li><li>■ The shiny side should face down.</li></ul>
Transparencies	<ul style="list-style-type: none"><li>■ Use only transparencies designed for this printer.</li><li>■ The transparency may have a paper backing or a paper tape on one edge. The paper or the tape should face up going into the printer.</li><li>■ The edge where the paper and transparency are joined or the taped edge of the transparency should go into the paper tray first</li></ul>
Banner paper (continuous computer paper or Z-fold paper)	<ul style="list-style-type: none"><li>■ Use plain paper banner paper.</li><li>■ If there are perforated strips, tear them off.</li><li>■ A torn edge at the top of the stack should go into the printer first.</li></ul>
Envelopes	<ul style="list-style-type: none"><li>■ Make sure the envelope flap is folded down flat.</li></ul>
Labels	<ul style="list-style-type: none"><li>■ To prevent misfeeds, put about 5 sheets of plain paper under the stack of labels you insert.</li><li>■ Put the labels in the tray face down.</li><li>■ In the Print dialog box, choose Plain from the Media pop-up menu.</li></ul>

For more information about paper sizes and specifications, see Appendix A and Chapter 2.



## Quality

For highest-quality printing of photographs or images, choose Best quality, use the color PhotoGrade ink cartridge and print on PhotoGrade papers.

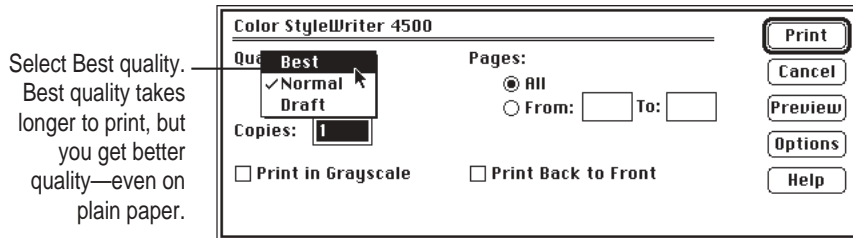

Also use the following selections in the Color Options dialog box. (To display the dialog box, click the Color button in the Print dialog box.)

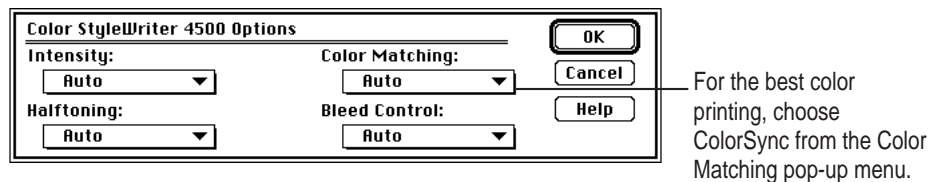

For the best color, you need to choose a specific profile for your monitor. In the ColorSync control panel, choose the D50 profile for your monitor. If there is no D50 available for your monitor, choose Apple Multiple Scan 17 – D50. The D50 profile gives you better “warm” colors.

For the best visual match between the colors on your monitor and printed colors, select the Page-White Gamma option in the Monitors control panel. (On some computers, the control panel is called Monitors & Sound.) To select a gamma option, open the Monitors control panel, then hold down the Option key while you click the Options button. In the Options window, click the Use Special Gamma checkbox to put a check in it. Then choose Page-White Gamma from the menu.

On a multiscan monitor, make sure that the color temperature, or intensity, is set to 9300 K (the default setting). See the monitor manual for instructions. If you select the Page-White Gamma option with a color temperature other than 9300 K, your monitor colors could look too red or too blue compared to printed colors.

For more information, see “Adjusting Color Options” in Chapter 2.

## Speed

For faster printing, change the Print Quality setting in the Print dialog box. (To display the dialog box, choose Print from the File menu.)

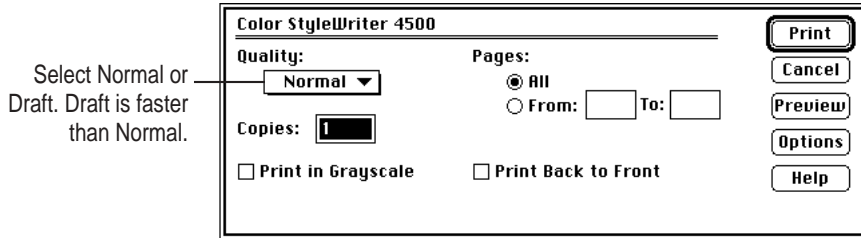

Color printing takes longer than black-only printing.

## Cost

To reduce the amount of ink you use, select Draft quality in the Print dialog box whenever possible.

For simple graphics or for documents that are mostly text, use the color and black ink cartridges. The color PhotoGrade cartridge should be used in place of the black cartridge only when you need the best quality photorealistic color printing.

# 4

## Maintaining Your Printer



It doesn't take much effort to keep your Color StyleWriter 4500 printer in good working condition. You simply have to replace the ink cartridges when they run out of ink and clean the printer or print head if you notice a problem. (For instructions on cleaning the printhead, see "Cleaning the cartridges" in Chapter 5.

For other service, see the information about service and support that comes with your Color StyleWriter 4500.

**IMPORTANT** Follow all the safety instructions given at the beginning of Chapter 1.

### Replacing ink cartridges

Look carefully at your printed documents to see if a color is missing or faded. Sometimes it's obvious—such as when you run out of black ink. At other times you may notice that the colors seem wrong—such as when you're printing a nature scene and you run out of yellow.

The best way to verify that ink is running low is to print the sample page. (For details, see "Printing the Sample Page" in Chapter 1.)

For instructions on replacing an ink cartridge, see "Installing the Ink Cartridges" in Chapter 1.

## Cleaning the outside of the printer

Before you clean the printer, turn it off and unplug the power cord. Then wipe the outside of the printer with a clean, soft cloth dampened with water. If necessary, you can use a mild soap or detergent. Be careful not to get any liquid in the power cord receptacle.

**WARNING** Don't use ammonia-based or alcohol-based cleaners on or around the printer—they may react with the plastic.



# 5

## Troubleshooting



This chapter provides solutions to some problems that you may encounter while using your Color StyleWriter 4500 printer.

As long as you follow the maintenance instructions in Chapter 4, you're not likely to have any problems with your printer. The most common source of trouble is faulty software installation. To avoid these problems, follow the software installation instructions in Chapter 1.

**WARNING** If you have a problem with your Color StyleWriter 4500 printer and nothing presented in this chapter solves it, consult the service and support information that came with the printer for instructions on how to contact an Apple-authorized service provider or Apple for assistance. If you attempt to repair the Color StyleWriter 4500 yourself, any damage you may cause to the printer will not be covered by the limited warranty on your printer. Contact an Apple-authorized dealer or service provider for additional information about this or any other warranty question.

## Safety precautions

To prevent damage to the Color StyleWriter 4500 printer and harm to yourself and other users, follow these safety tips.

- Don't touch anything inside the printer except as described in the instructions in this manual. Otherwise, you may damage delicate mechanical parts.
- Don't shake ink cartridges. Ink can leak out and cause stains.
- Don't touch the ink opening on an ink cartridge.
- Don't oil the inside of the printer.
- Don't attempt to disassemble the printer.
- Before you unplug the printer, make sure it is turned off. (The green power light should be off.) Turning the power off ensures that the carrier has returned securely to its home position and the cartridges have been capped.

## The Chooser doesn't show the Color SW 4000 Series icon

If you open the Chooser and don't see the Color SW 4000 Series icon, you probably need to install the appropriate printer software. For instructions, see "Installing Your Printer Software" in Chapter 1.

Also, make sure the QuickDraw GX software is turned off. You can remove it from the Extensions folder or use the Extensions Manager to turn it off.

## Installation is unsuccessful

If a message tells you that installation was not successful, check to make sure you turned off virus-detection software as explained in Chapter 1. If that doesn't work, try removing corrupted fonts, as described in the next section.

## Removing items from your Fonts folder to solve installation problems

Items in your current Fonts folder can interfere with successful installation of the printer software. To correct the problem, follow these steps:

- 1** Quit all programs you are currently running.
- 2** Open the Fonts folder (inside the System Folder) on your computer.
- 3** Drag the following files out of the Fonts folder. (Look for files with exactly these names.)
  - Avant Garde
  - Bookman
  - Delphian
  - Garamond Narrow
  - Helvetica Black and Helvetica Compressed
  - Lubalin Graph
  - Lucida Bright
  - Machine
  - N Helvetica Narrow
  - Nadianne
  - New Century Schlbk
  - Old English Text
  - Onyx
  - Oxford
  - Swing
  - Zapf Chancery
  - Zapf Dingbats
  - Zeal

You can put the fonts temporarily into a new folder and drag the folder to your desktop. Then, after you install the Color StyleWriter 4500 software (including these fonts), you can drag the temporary folder to the Trash.

- 4** Repeat the software installation procedure in Chapter 1.

For more details about fonts, see Appendix B.

## The computer crashes while attempting to print

When a computer suddenly stops working—either a message on the screen tells you a system error has occurred, or the mouse and keyboard act as if they’re disconnected—the computer has crashed.

If your computer often crashes after you tell it to print a document, your printing software may have become corrupted. Reinstall the printer software by following the instructions in “Installing Your Printer Software” and “Telling Your Computer to Use the Color StyleWriter 4500” in Chapter 1.

## The computer doesn’t recognize the Color StyleWriter 4500

If you have selected the Color StyleWriter 4000 Series icon in the Chooser but nothing prints, or you get a message that no Color StyleWriter 4500 is connected, one of the conditions in the list that follows may be the cause.

*Note:* Before you try to solve the problem, choose CSW 4000 Series PrintMonitor from the Application menu to see if there are any error messages and to check how many print requests are waiting. If you repeatedly tried to print a document, there may be multiple copies waiting to print. You can delete anything you don’t want by selecting its title, and then clicking the Cancel Printing button. See “Monitoring and Controlling Background Printing” in Chapter 2.

- A plug may be loose. To make sure that all cables are securely connected, turn off the computer and the printer, then unplug each end of each cable you want to test and plug it back in. For connection instructions, see Chapter 1.
- You may have indicated the wrong port in the Chooser. Open the Chooser and change the port selection. (Look at the back of the computer to see whether you plugged the printer into the computer’s printer port [🖨️] or modem port [📠].)
- If your computer is not connected to a network, turn off AppleTalk in the Chooser.



- If you are trying to use a printer on a network, and the printer name isn't listed in the Chooser, make sure that the printer is turned on and connected to the network. Then try again to select the printer in the Chooser.
- If the printer is connected to a LocalTalk network, select the CSW 4000 Series (AT) in the Chooser, and make sure that AppleTalk is active. (The "AT" in the driver name stands for AppleTalk.)
- If the printer is on a LocalTalk network, someone may have given it a new name.
- You may be using the wrong printer software. Make sure you installed the software as described in Chapter 1 and that you have selected the printer as described in "Telling Your Computer to Use the Color StyleWriter 4500," also in Chapter 1.
- If you're using a PowerBook computer with an internal modem, change the serial port setting to Normal or External. For details, see "Special Information for PowerBook Owners" in Chapter 1.
- The printer may need to be reset. Turn the printer off, count to five, then turn it back on.

If you still can't resolve the problem, the printer may not be working properly. See the information about service and support that came with your printer.

## **A PowerBook has trouble printing to the Color StyleWriter 4500**

Some PowerBook computers have special requirements for printing. See "Special Information for PowerBook Owners" in Chapter 1.

## The lights indicate a problem

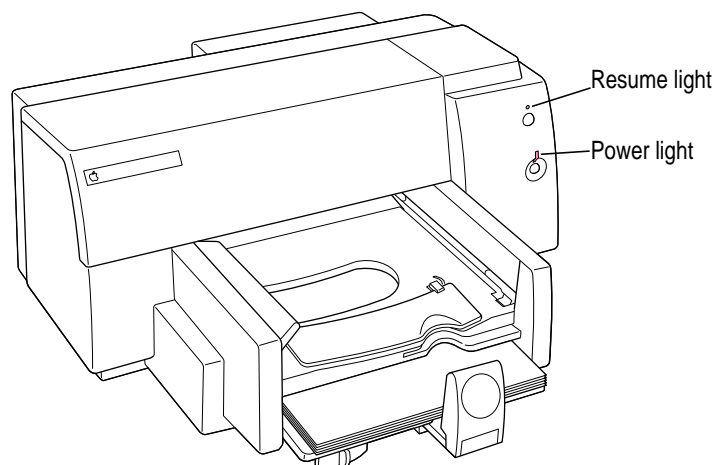

Sometimes the lights on the printer signal a problem.

### **Both lights are off.**

- The printer is turned off. Press the power button. If you still don't see the glowing green light, make sure the printer is plugged into a power outlet and that the outlet has power.

### **Both lights blink.**

- Paper may be jammed in the printer. Open the front cover and remove any jammed paper. To advance paper that is part way through the printer, press the resume button. Close the front cover and turn the printer off, then on again.
- The ink-cartridge carrier may be jammed. Close the front cover, turn the printer off, then on again.

### **The power light blinks, and the resume light is off.**

- This is normal behavior when the printer is receiving data, printing, or waiting for ink to dry.

### **The power light glows steadily, and the resume light blinks.**

- One or both of the ink cartridges may not be seated properly, or you may have forgotten to remove the tape from a new cartridge. Open the front cover. Remove both cartridges. Holding the black plastic sides of the cartridge, check to be sure the tape has been removed from the print head. Then replace the cartridges in the carrier. Make sure each cartridge is pressed all the way into the carrier. If a cartridge feels at all loose, it is not properly seated. For instructions, see “Installing the Ink Cartridges” in Chapter 1.
- The front cover may be open. Make sure it is closed.
- There may be no paper in the lower paper tray. Load paper.
- If you just printed a banner, you need to unload the remaining banner paper. Tear off the unused paper in the tray. Then press and release the resume button to advance the end of the banner through the printer.
- The printer may be confused. Press and release the resume button.

## **The printer seems slow**

See the suggestions under “Speed” in Chapter 3.

If you have a Macintosh IIfx, Macintosh Quadra 900, or Macintosh Quadra 950 computer, check the Serial Switch control panel. Make sure it is set to Compatible.

## **Paper is jammed**

Occasionally a piece of paper may get stuck inside the printer during the printing process. To clear a paper jam, follow these steps:

- 1** If necessary, open the front cover to see where the jam is.
- 2** Gently pull the paper free.
- 3** To advance any remaining paper, press and release the resume button.
- 4** Turn off the printer, then turn it on again.

## Paper or envelopes feed improperly

If paper tears, gets skewed, or comes through the printer crumpled, it may not be entering the printer properly. Try the following:

- **Make sure you have loaded the paper correctly, paying special attention to both paper adjusters.**

For instructions on loading paper, see “Loading Paper into the Paper Tray” in Chapter 1.

- **Do not overload the paper tray.**

If you use heavier paper, fewer sheets will fit in the paper tray.

- **Do not force paper into the paper tray.**
- **Try to remove any torn or damaged pieces of paper from the printer.**

See “Paper Is Jammed,” earlier in this chapter.

- **Take the paper out of the paper tray and check it.**

Make sure none of the sheets is curled, bent, or dog-eared.

Make sure the edges of the stack line up evenly.

Make sure the paper adjusters aren’t too snug or too loose. The stack should lie flat (not bowed).

Load either envelopes or paper (not both) into the paper tray.

Make sure you have inserted envelopes correctly. The flaps should lie flat against the envelope, the edges should be smoothed flat, and no air should be trapped in the envelopes.

When loading transparencies, the side with the tape or the paper backing should face up. The taped edge or the edge where the paper and the transparency are joined should go into the paper tray first.

## The Color StyleWriter 4500 won't print a particular document

If you attempt to print a document and no page is printed—not even a blank one—try the following:

- Check for messages on your computer screen. Also, choose CSW 4000 Series PrintMonitor from the Application menu.
- Your computer may be low on memory. See “Memory Is Low,” later in this chapter.
- Turn the printer off, then on again. (This resets the printer.)
- Repeat the printing process.

Sometimes problems disappear when you try to print your document again.

- Printing problems can often be caused by errors in your applications. If you can print from the SimpleText or TeachText application but not from another application, it's probably a problem with that application. Contact the publisher of that application for help.
- Restart your computer.

## The printer acts as if it's working, but nothing is printed on the page

If your printer takes the paper, but doesn't actually print anything, try the following:

- If the ink cartridge is new, make sure that you removed the tape from its print head.
- Make sure the ink cartridges are correctly installed. (For instructions, see “Installing the Ink Cartridges” in Chapter 1.)
- The printer may be out of ink, or the cartridges need to be cleaned. You can check by seeing whether the sample page prints. See “Printing a Sample Page” in Chapter 1. For instructions on cleaning the cartridges, see “Cleaning the Cartridges,” later in this chapter.

## Messages appear on your computer screen

Most messages that appear on your screen are self-explanatory. For example, they may tell you that the printer is out of paper or that the paper is jammed. Once you correct the problem, the message goes away.

These messages usually mean what they say. Occasionally they appear when you have the wrong port indicated in the Chooser. See “Telling Your Computer to Use the Color StyleWriter 4500” and “Special Information for PowerBook Owners” in Chapter 1.

## Memory is low

Once in a while, your computer may be temporarily low on random-access memory (RAM).

### Symptoms that indicate a memory problem:

- Some documents do not print.
- Some text incorrectly appears in the Geneva font.
- Characters look jagged.
- An “out of memory” message appears on your screen.

### If you have a memory problem, try the following:

- Run only one program at a time; quit the ones you’re not using.
- If memory has been severely fragmented, you should quit all open applications, then reopen just the one you’re using.
- Increase the amount of memory you give to the program you’re printing from by using the Get Info command (as explained in the instructions that came with your computer)
- Turn off background printing. See “Printing While You Use Your Computer” in Chapter 2.
- In the Page Setup dialog box, choose Portrait (normal) orientation instead of Landscape (sideways) orientation.
- Print color documents using “Print in Grayscale” in the Print dialog box. Printing in grayscale takes the least memory.

- Turn on virtual memory in the Memory control panel. Virtual memory is described in the instructions that came with your computer. (*Note:* Using virtual memory can slow down your computer.)
- Obtaining additional RAM for your computer can solve some of these problems and improve printing speed.
- Restart your computer. Some software applications retain memory resources even after you have quit the application. The only way to recover this memory is to restart.

## Documents did not print as expected

If the quality of printing is OK—not smeared or incomplete—but the result is not as you expected, you may have made a mistake in using the printer software. For example, in the Page Setup dialog box, someone might have checked “Save as Default.” If it is checked, and you are not getting the results you expect when you print, click the checkbox to remove the X. Make sure the settings in Page Setup are what you want, and then try printing again.

For additional help, read the subsections that follow for suggestions.

## Text appears in the Geneva font or prints jagged

When your computer is low on memory, it may display and print certain fonts in the Geneva font (*Geneva looks like this.*) Some text may also have jagged edges. To fix low-memory problems, see the preceding section, “Memory Is Low.”

For more information about fonts, see Appendix B, “Using Fonts With the Color StyleWriter 4500.”

Some rotated text may print jagged if you apply a style that has not been defined for the font. Try applying plain style to the text.

## Graphic images appear jagged

Some advanced page layout and art applications use the PostScript page description language, a language that the Color StyleWriter 4500 does not understand. If your applications have a PICT preview option, you can print the file on a Color StyleWriter 4500. Images saved as encapsulated PostScript (EPS) may appear jagged on all non-PostScript printers. For normal color images, substitute a TIFF or PICT version of the image.

## Page breaks change unexpectedly

Most applications determine where to break pages by evaluating the information you provide in the Page Setup dialog box. Also, different types of printers space text in slightly different ways. The following actions can cause page breaks to change:

- changing from one type of printer to another
- changing the paper size in the Page Setup dialog box
- scaling the document in the Page Setup dialog box
- changing the orientation in the Page Setup dialog box

It's best to choose the printer you want and the Page Setup options you need before working on your page breaks.

## A page prints off center

This problem may result from one of the following conditions:

- You have selected the wrong paper size in the Page Setup dialog box.
- The margins are set incorrectly in the document you are printing.
- Paper is not placed properly in the paper tray. See “Paper or Envelopes Feed Improperly,” earlier in this chapter.



### Text lines up in columns on the screen but not when it prints

You may have used spaces (rather than tabs) to line up the text. Because printers interpret spaces differently than the screen does, the text may fail to line up when you print it. Try replacing the spaces with tabs.

You can also make columns by using spaces with a monospace font—such as Courier or Monaco—instead of tabs. A monospace font is one in which every character has the same width.

### Everything prints backwards

Choose Page Setup from the File and see whether there's an X in the “Flip Horizontal” checkbox. If so, click to make the X disappear.

## Print quality is poor

Most image problems are caused by problems with an ink cartridge or with your choice of paper. Don't use the following types of paper:

- erasable typing paper
- damaged, wrinkled, or stapled paper
- multipart forms (“carbonless carbons”)
- glossy paper, unless its especially designed for StyleWriter printers

For best print quality, use coated, glossy, or PhotoGrade paper. If you use plain paper, use 16- to 36-pound copier paper; 20-pound paper is recommended. Plain papers can vary widely. If you're not happy with one kind of paper, try a different brand.

## The image is too light or too dark

If printing looks fuzzy because it's too light or too dark, try the following:

- Clean the cartridges. See “Cleaning the Cartridges,” later in this Chapter. If this doesn't help, replace one or both ink cartridges. See “Installing the Ink Cartridges” in Chapter 1 for instructions.
- Make sure you've chosen the correct paper type in the Print dialog box.
- If you're using plain paper, try flipping the stack of paper in the paper tray. Most paper has one side that's better for printing. If you're using other material, make sure you have it loaded in the correct orientation. See “Loading Paper into the Paper Tray” in Chapter 1.
- Try printing on a different kind of paper.
- Try choosing Best print quality in the Print dialog box.
- Try adjusting the Intensity control. Choose Page Setup or Print from the File menu, and then click Options. In the dialog box that appears, choose a different setting in the Intensity pop-up menu.

## Thin lines fade or break up

Pick a darker color for the affected object, or try printing with the Pattern halftoning option selected. (In the Print dialog box, click the Options button, then choose Pattern from the Halftoning pop-up menu.)

## The ink smears when rubbed

Don't handle pages before the printer drops them into the output tray. Wait several minutes before handling documents printed on glossy or PhotoGrade paper or on transparency film.

## Printing appears on only part of the paper

Check the selections in the Page Setup dialog box.

Clean the cartridges. See “Cleaning the Cartridges,” later in this Chapter. If this doesn't help, replace one or both ink cartridges. See “Installing the Ink Cartridges” in Chapter 1 for instructions.

## Colors don't look right on the printed page

Try the following:

- Print a sample page to see if you've run out of ink. For instructions, see "Printing a Sample Page" in Chapter 1.
- Clean the cartridges. See "Cleaning the Cartridges," later in this Chapter. If this doesn't help, replace one or both ink cartridges. See "Installing the Ink Cartridges" in Chapter 1 for instructions.
- Try printing the image with ColorSync turned on. See "Quality" in Chapter 3.
- Use a different type of paper.
- Make sure you've selected the paper you're printing on from the Paper Type pop-up menu in the Page Setup dialog box.

## Unwanted horizontal white lines or stripes appear

Problems with print quality, especially horizontal white lines in your document, may mean a nozzle on the print head is clogged or your ink cartridge is running out of ink.

Clean the cartridges. See "Cleaning the Cartridges," later in this Chapter. If this doesn't help, replace one or both ink cartridges. See "Installing the Ink Cartridges" in Chapter 1 for instructions.

**IMPORTANT** Cleaning the cartridges consumes a small amount of ink. If you repeat the procedure unnecessarily, you reduce the life of your cartridges.

## Cleaning the cartridges

To clean the print head, load plain paper in the paper tray and make sure the printer is turned on. Then follow these steps:

- 1 **Click Utilities in the Page Setup dialog box.**

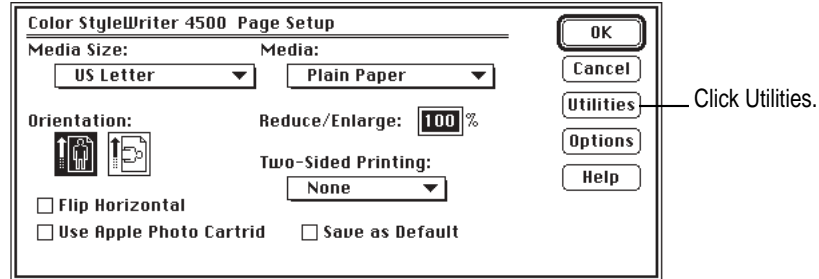

- 2 **In the Utilities dialog box, find Clean Print Cartridges and click Start.**

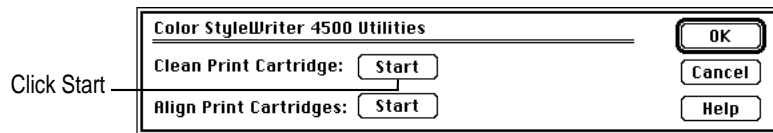

The printer cleans the print head, printing a page in the process.

## The image prints wavy or distorted

Make sure that you are using a recommended type of paper. If the problem persists, see the information about service and support that comes with the printer.

## Stains appear on printed pages

Stains on the backs or tops of printed pages may mean that ink has spilled inside the printer. If so, the ink can transfer to the rollers and from there to the paper.

Turn the printer off and unplug it. Then open the printer and carefully clean the rollers and platen with a soft, dry cloth.

## Ink cartridges run out of ink too quickly

To extend the life of your ink cartridges, try the following:

- Select Draft print quality in the Print dialog box whenever you can.
- Don't clean the print head unless necessary.
- Don't print solid background colors unless necessary.
- Don't print the sample page unless necessary.





## Appendix A Technical Information

• • • • •

### General specifications

#### Marking engine

- Four-color thermal ink-jet engine; six-color with the color PhotoGrade ink cartridge

#### Resolution

The resolution differs according to the quality of printing you select. It is expressed in horizontal by vertical dots per inch (dpi).

- Best Black: 600 x 600 dpi
- Best Color: 600 x 300 dpi on coated or glossy paper or on transparencies (300 x 300 dpi on plain paper)
- Normal Black: 600 x 300 dpi
- Normal Color: 600 x 300 dpi on glossy paper or transparencies (300 x 300 dpi on plain or coated paper)
- Draft Black: 300 x 300 dpi
- Draft Color: 150 x 300 dpi

#### Engine speed

- Printing speed depends on the images printed and on the Mac OS-based computer used.

**Connector cable**

- Apple System/Peripheral-8 cable

**Interface**

- LocalTalk
- High-speed serial (RS-422-A)

**Fonts**

- TrueType font support
- 64 TrueType fonts including the fonts provided on your computer
- Adobe PostScript font support when used with Adobe Type Manager software (sold separately by Adobe Systems Incorporated)

**Lower paper tray**

- Holds up to 100 sheets of 20-pound (75 grams/meter<sup>2</sup>) paper, 20 envelopes, 20 sheets of banner paper, up to 30 cards, up to 50 transparencies, up to 25 sheets of paper labels.

**Output tray**

- Holds up to 50 sheets of 20-pound (75 grams/meter<sup>2</sup>) paper.

**Printing materials**

- Plain paper: Use 16-pound (60-g/m<sup>2</sup>) to 36-pound (135-g/m<sup>2</sup>).
- Envelopes: Use C6, DL, A2, or #10 envelopes, 20 to 24 lb. (75 to 90 g/m<sup>2</sup>).
- Continuous banner paper: Use 20 lb. (75 g/m<sup>2</sup>).
- Labels: Accepts paper labels designed for ink-jet printers.
- Cards: Use 110 lb. index maximum, 8.5 pt. maximum (110 to 200 g/m<sup>2</sup>).
- Apple recommends transparency film, premium coated paper, glossy paper, and color PhotoGrade paper especially designed for the Color StyleWriter 4500 printer. See your Apple-authorized dealer for more details.





**Paper sizes in inches (") and millimeters (mm)**

- U.S. Letter: 8.5" x 11" (215.9 mm x 279.4 mm)
- Banner U.S. Letter: 8.5" x 11" (215.9 mm x 279.4 mm)
- U.S. Legal: 8.5" x 14" (215.9 mm x 355.6 mm)
- Executive: 7.25" x 10.5" (184.15 mm x 266.7 mm)
- A4: 8.3" x 11.7" (210 mm x 297 mm)
- Banner A4: 8.3" x 11.7" (210 mm x 297 mm)
- A5: 5.8" x 8.3" (148.5 mm x 210 mm)
- B5 JIS: 7.2" x 10.1" (182 mm x 257 mm)
- #10 envelopes: 9.5" x 4.125" (241.3 mm x 104.8 mm)
- C6 envelopes: 4.48" x 6.37" (114 mm x 162 mm)
- DL envelopes: 4.33" x 8.66" (220 mm x 110 mm)
- A2 envelopes: 4.375" x 5.75" (111 mm x 146 mm)
- US Card 4x6: 4" x 6" (101.61 mm x 152.4 mm)
- US Card 5x8: 5" x 8" (127 mm x 203.2 mm)
- A6 card: 4.1" x 5.83" (105 mm x 148.5 mm)
- Hagaki card: 3.9" x 5.8" (100 mm x 148 mm)

**Printable area in inches (") and millimeters (mm)**

- Maximum printable line in portrait (normal) orientation: 8" (203.2 mm)
- Minimum margins
  - Left and right: 0.25" (6.4 mm)
  - Top: 0.26" (6.6 mm)
  - Bottom: 0.59" (15.0 mm)

**Dimensions in inches (") and millimeters (mm)**

- Height: 7.9" (199 mm)
- Width: 17.2" (436 mm)
- Depth: 16" (405 mm)

**Weight**

- Approximately 11.6 pounds (5.3 kilograms)

## Operating environment

### Temperature

- 5° to 40° C (41° to 104° F)

### Relative humidity

- 10 percent to 80 percent, noncondensing

## Storage environment

### Temperature

- -40° to 60° C (-40° to 140° F)

### Humidity

- 5 percent to 90 percent, noncondensing

## Power consumption

### Operating

- 2 watts maximum when off
- 4.5 watts maximum nonprinting
- 12 watts maximum when printing

## Power requirements for AC power adapter

The electrical requirements vary depending on the country for which your model was manufactured.

### Power supply

- AC power adapter



## Apple printer supplies and accessories

If you have trouble finding any of the following products, the part numbers may help you describe them to the dealer. Note, however, that part numbers sometimes change as products are enhanced.

### Ink cartridges

- Color ink cartridge: M5694G/A
- Black ink cartridge: M5693G/A
- Color PhotoGrade ink cartridge: M5692G/A

### Connector cable

- Apple System/Peripheral-8 cable: M0197LL

### Printing materials

Apple offers a complete line of high-quality, specialty ink-jet papers for use in your printer. These papers are specially designed to make your output look sharper, brighter, and more vibrant. Look for them at an Apple-authorized dealer.

- Apple Color Ink-Jet Transparency Film
- Apple Color Ink-Jet Premium Coated Paper
- Apple Color Ink-Jet Glossy Paper
- Apple Color Ink-Jet Color PhotoGrade Paper
- Apple Color Ink-Jet Banner Paper
- Apple Color Ink-Jet Greeting Card Kit

### Available Options

- LocalTalk RJ-11 Connector Kit DIN-8: M1657Z/A
- LocalTalk Locking Connector Kit DIN-8: M2068LL/B

## Where can you obtain these supplies and accessories?

See any Apple-authorized dealer. In the U.S., call 1-800-538-9696 for the location of the dealer nearest to you.





## Appendix B Using Fonts With the Color StyleWriter 4500



A font is a collection of letters, numbers, and symbols in a distinctive typographic design. Your Mac OS–based computer and Color StyleWriter 4500 printer come with a variety of fonts that look great both on your monitor and on paper.

Fonts come in such a variety of formats that problems can sometimes arise. This appendix provides the information you need to avoid such problems and to solve them if they come up.

### Kinds of fonts

The Mac OS–based computer works with three main kinds of fonts: TrueType, bitmapped, and PostScript fonts.

Two kinds of fonts come with your computer and the Color StyleWriter 4500 printer: TrueType and bitmapped. However, your system can use PostScript fonts as well when it has the proper software installed.

## TrueType fonts

A TrueType font is scalable, describing a typeface without rigidly specifying a size. So it looks good whatever size you choose. TrueType fonts provide sharp text at any size on screen or on paper. You can mix and match TrueType fonts from various font vendors.



Courier

TrueType fonts store individual text characters as mathematical descriptions of lines and curves, rather than as groups of pixels (a bitmap). When a program asks for a character in a particular size, such as 33 points, the computer uses mathematical calculations to enlarge the character's outline to 33 points and fill in the dots for the monitor or printer output.

Sometimes you'll still get jagged edges when you print a document, even when you use a TrueType font. In nearly all cases, this is because there isn't enough memory available to scale the font properly for printing. This may happen, for example, when you're running several programs at the same time.

Because you don't need a separate font for each character size in order for your printing to look good (as you do with bitmapped fonts), TrueType font names don't have numbers in them.

*How does a font look?* To see what a TrueType or bitmapped font looks like on your screen, double-click the font's icon to open it. A sample of that font appears (in three sizes for TrueType fonts and in the size you opened for bitmapped fonts).

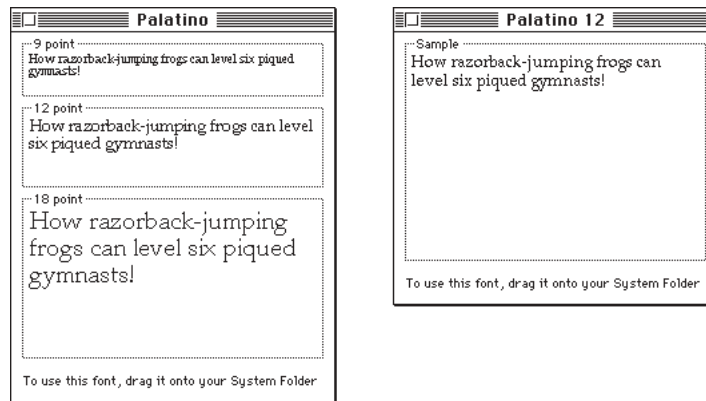

You can also use the Key Caps desk accessory to examine fonts. See the documentation that came with your computer for instructions.

## Bitmapped fonts

Bitmapped fonts consist of “pictures” of a typeface at specific sizes. For example, you might have bitmapped fonts at 10-, 12-, and 18-point sizes installed in your computer. For best results you need a separate font file for each size of character you want to use.

The icon of a bitmapped font (also called a *fixed-size font* or *screen font*) has the single letter *A* on it. The font's point size appears at the end of its name.



When you request a bitmapped character, your looks for an installed bitmapped font in the size you specified. (See “How the Computer Looks for Fonts” later in this appendix.) If it can't find that font, your computer tries to construct one by scaling a size that it does find.

In most cases, scaled bitmapped fonts don't look nearly as good as preinstalled ones. Such scaling is one reason for the jagged edges (sometimes called "jaggies") you'll see on your screen or in a printed document when you request an uninstalled size (for example, 17-point Geneva).

Bitmapped fonts are designed on grids of 72 dots per inch (dpi)—the standard Mac OS–based computer screen resolution. Because of their correspondence to the standard screen resolution, bitmapped fonts in preinstalled sizes always look great on your display.

When you print a bitmapped font, it prints at a resolution of 72 dpi. Because most modern printers can print at resolutions far better than this (your Color StyleWriter 4500 prints at 300 dpi or better), printed bitmapped fonts almost always have jagged edges or stairstep sides.

Fortunately, the computer can use bitmapped fonts in combination with other font formats, reserving bitmaps for the screen and other kinds of fonts for the printer.

## PostScript fonts

PostScript is a page-description language that defines the characters, symbols, and images that appear on each page of a document. A PostScript font comes as a pair of fonts: an outline font for the printer and a corresponding bitmapped font for displaying type on your screen.

*No bitmapped font, no menu entry:* If your system doesn't have the bitmapped font, the PostScript font name won't appear in your font menu.



Certain printers are designed specifically to work with PostScript fonts. While your Color StyleWriter 4500 is not a PostScript printer, it can use PostScript fonts if you have Adobe Type Manager software installed. Adobe Type Manager uses printer fonts to generate clean-looking screen text at any size. (This software is included with some installations of system software 7.5. It is available from your local Apple-authorized dealer for version 7.1.)



**IMPORTANT** Adobe Type Manager is not an Apple product. It is made and supported by Adobe Systems Incorporated. Only the version that comes with Apple Macintosh system software version 7.5 is supported by Apple.

PostScript printer fonts have no numbers associated with their names, because a single font can be scaled to any size. Many companies make PostScript fonts; the following illustration shows icons for Adobe, Bitstream, and Fontek PostScript fonts, plus a generic PostScript font icon.



## How TrueType fonts work with other kinds of fonts

Although TrueType fonts offer distinct advantages, your Color StyleWriter 4500 printer can also use other kinds of fonts.

### TrueType and bitmapped fonts

Mac OS–based computers running System 7 come with both bitmapped (screen) fonts and TrueType fonts installed. This maintains consistency with documents created on Mac OS–based systems that don't have TrueType fonts.

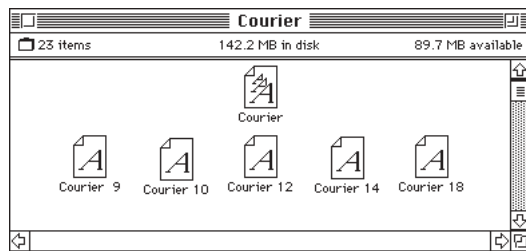

Bitmapped fonts look better displayed on the monitor, while TrueType fonts look better on a high-resolution printer such as the Color StyleWriter 4500. So, if you have both versions of the font available, your computer uses the bitmapped version when displaying the font on the screen (provided that the size you're using is available) and the TrueType version when printing the font on the Color StyleWriter 4500. To force the Macintosh to use only TrueType fonts everywhere, you must remove the bitmapped fonts.

For example, if a document uses 12-point Times®, available in that size as a bitmapped font and as a TrueType font, the system uses the bitmapped font on the screen and the TrueType font on the printer. If a document uses 4-point Times, the system scales the TrueType font to that size for both the screen and the printer, because a bitmapped version isn't available.

Using only TrueType fonts produces a closer match between the appearance of type on the screen and on paper. However, a document you've already created with bitmapped fonts will be reformatted with the corresponding TrueType fonts, and line breaks in the document may change. Similarly, if a document is created on a system that has TrueType fonts or Adobe Type Manager software installed, it may have different spacing, kerning, and so on, when opened on a system that doesn't have TrueType fonts or Adobe Type Manager software.

### Keeping two font versions available

If you have a TrueType version of a font, you don't need a bitmapped version. However, although keeping both versions of a font takes up more disk space, there are several advantages to doing so.

Bitmapped fonts are hand-designed: a graphic artist planned each character in each font to look good on a screen. TrueType fonts are scaled by the computer to match what you request. At smaller point sizes, the bitmaps may appear sharper on the screen.

Additionally, scaling fonts takes time—sometimes up to several seconds in slower Macintosh computers—but all Macintosh computers can display a bitmapped font instantly.

### TrueType and PostScript fonts

PostScript fonts were designed as fonts for PostScript printers. The Color StyleWriter 4500 wasn't designed to use PostScript. However, if you have Adobe Type Manager software installed, your computer can both display and print PostScript fonts.

*Use different names:* To avoid confusing the printer software, be sure that you don't install both TrueType and PostScript versions of the same font. For example, do not have a PostScript font file called *Times* and a TrueType font file called *Times* installed in your system at the same time.

## How the computer looks for fonts

Here's the search order your computer uses to determine which font to display on your screen when you choose a specific size:

1. an installed bitmapped font in that size, if one exists
2. a scaled TrueType font, if no bitmapped font exists
3. an Adobe Type Manager (ATM) version of a PostScript font, if ATM is installed and if no TrueType version exists
4. a scaled bitmap if no ATM font exists

Here's the search order it uses to determine which font to print on your Color StyleWriter 4500 printer:

1. a scaled TrueType font, if one exists
2. an ATM version of a PostScript font, if ATM is installed and if no TrueType version exists
3. a scaled 72-dpi bitmap if no ATM font exists

## Where fonts are stored

All fonts for your Color StyleWriter 4500 printer reside in special places within the System Folder. To install fonts, you drag them to the System Folder. Your Macintosh will automatically put them where they belong—in the Fonts folder within the System Folder.

The Fonts folder can contain a total of 128 font suitcases (described in the next section), plus any number of PostScript fonts, up to the available storage capacity of your hard disk.

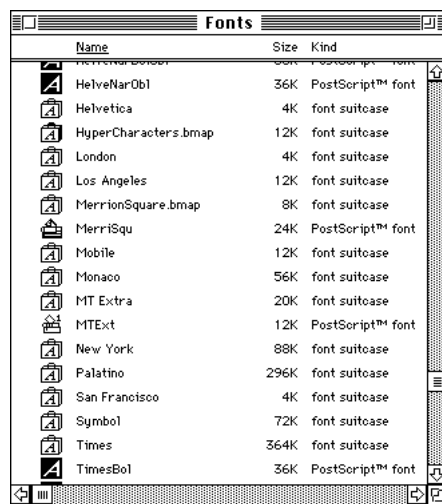

**IMPORTANT** Fonts installed in other folders or in the top level of the System Folder may not work correctly. Additionally, bitmapped and TrueType fonts stored outside of suitcases may not work correctly.

## Suitcases

A font suitcase is a special folder for collections of fonts.



Suitcases provide a convenient way to organize fonts in the same font family. For example, it's a good idea to use a single suitcase (called *Courier*) for all fonts in the Courier font family—all Courier roman fonts as well as fonts with names like Courier Bold and Courier Oblique.

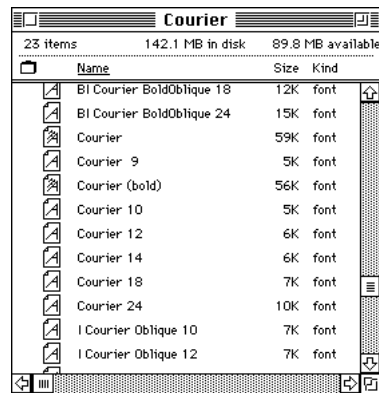

*Combining suitcases:* To merge all the fonts from one suitcase with another, drag one suitcase on top of the other. All the fonts from the dragged suitcase will go into the other, and the dragged suitcase will disappear.

*Note:* To avoid confusion, rename a font suitcase whenever you put more fonts into it. For example, if you decide to merge Helvetica, Helvetica Black, and Helvetica Compressed, name the suitcase something like “Helvetica Regular/Black/Condensed.”

A suitcase can also contain fonts from different font families, although you should keep all fonts of the same family in the same suitcase. All the fonts will still appear in menus with their proper names.

You treat a suitcase as you would a folder. To open a suitcase, you double-click it. To add a font, you drag the font's icon to the suitcase and drop it in. To remove a font, you drag its icon out of the suitcase.

To create a font suitcase, duplicate an existing one and throw away its contents. Then rename the suitcase as appropriate and drag whatever fonts you want into it.

You cannot have more than 128 font suitcases in the Fonts folder.

*Size limits for suitcases:* No matter how many fonts you have in a single suitcase, the Fonts folder counts the suitcase as a single unit. There's no limit to the number of fonts in a single suitcase, but the suitcase cannot be larger than 16 megabytes.

## Styled fonts

Most fonts that come with your Color StyleWriter 4500 printer have defined styles. For example, if you open the Bookman font (contained in a suitcase in the Fonts folder, which is inside your System Folder), you see files for bold and italic versions of the font.

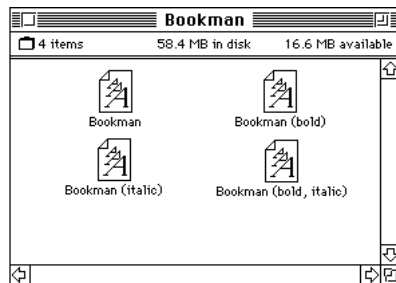

But fonts such as Chicago, Geneva, Monaco, and New York do not come with defined styles. If you open the Chicago font suitcase, you see only one file.



You can apply a style to a font like this by making a choice from the appropriate menu (Fonts, Style, Format, or some similar menu, depending on the application program). A font predesigned with a given style nearly always looks better than a font with a computer-generated “derived” style.

*About style names:* Predesigned styled fonts sometimes have names you may not be familiar with. For example, *roman* refers to a font without styling, or plain. *Oblique* is similar to italic. *Light*, *demi*, and *extra* are different kinds of bold.

## Common questions about fonts

Here are some questions that often come up about fonts.

### What kind of fonts should I buy?

Using a font that has both bitmapped and TrueType versions works best. The bitmapped version looks great on the screen and the TrueType fonts print beautifully on the Color StyleWriter 4500.

Avoid bitmapped fonts that don't have TrueType versions because they print with jagged edges on the Color StyleWriter 4500. By contrast, TrueType fonts work well, even if you don't have a bitmapped version.

If you have a PostScript printer or Adobe Type Manager, PostScript fonts look great on paper. The Color StyleWriter 4500 is not a PostScript printer.



### Why don't all of my fonts appear in the Fonts menu?

You may not have all of your fonts placed correctly. All the fonts should be installed in the Fonts folder in the System Folder.

Additionally, some application programs let the user decide which fonts should appear in the Fonts menu. Check the manuals that came with your programs.

### Why can't I see my Monaco 9, Geneva 9 and 12, and Chicago 12 bitmapped fonts?

These fonts are used by your Mac OS–based computer to display information. Because the computer needs these fonts, the Finder makes them invisible to prevent users from removing them.

### What does the term *Apple classic fonts* mean?

The Apple classic fonts are the original ten bitmapped fonts that came with the first Macintosh in 1984. These fonts, which all have city names, include Athens, Cairo (a picture font), Chicago, Geneva, London, Los Angeles, Monaco, New York, San Francisco, and Venice. Several of the fonts (Athens, Cairo, London, and San Francisco) came in only one size—18 points.

#### **This is a sample of Athens.**



#### **This is a sample of Chicago.**

This is a sample of Geneva.

#### **This is a sample of London.**

*This is a sample of Los Angeles.*

This is a sample of Monaco.

This is a sample of New York.

#### **This is a sample of San Francisco.**

*This is a sample of Venice.*

Chicago, Geneva, Monaco, and New York are currently available in TrueType versions. The other classic fonts are still only available in bitmapped versions.

### Why do I sometimes get Geneva or Courier in my printed documents when I have specified other fonts?

Geneva sometimes appears when you're trying to use a TrueType font but don't have enough memory for scaling to operate properly.

Substitute fonts can also appear in a document composed on one Macintosh that has a particular set of fonts but printed on another Macintosh that doesn't have those fonts.

**Why does a document written entirely in Times look different on different Macintosh computers?**

Times, an extremely popular font, is manufactured and sold by more than one company. Such fonts usually have small differences, even though they have the same name. For example, the Times font manufactured by Adobe Systems Incorporated has different letterspacing than does the Times font from Apple Computer, Inc.

**What is font substitution?**

Font Substitution, which isn't available for your Color StyleWriter 4500 printer, is an option in the Page Setup dialog box for certain PostScript printers. When font substitution is turned on, these printers will use their built-in equivalents for three bitmapped fonts (Times for New York, Helvetica for Geneva, and Courier for Monaco).

**What's a downloadable font?**

A downloadable font is a TrueType or PostScript font sent to some kinds of printers, such as most PostScript Laser printers, by your system software. The printer then uses the font to print your document.

If a printer has sufficient memory, it can hold more than one downloaded font; otherwise, it must request the fonts it needs as necessary. This can be a time-consuming process.

Some printers have hard disks attached to them for holding downloaded fonts. A printer can get the fonts from its hard disk more quickly than it can download them from the computer's hard disk.

Your Color StyleWriter 4500 printer cannot receive downloaded fonts. Instead, your computer composes the entire image and then sends it to your Color StyleWriter 4500 for printing.



## Appendix C Font List



Between the fonts that come with your Mac OS–based computer and those that come with the printer, there are 28 font families (and 64 total styled fonts) available as soon as you install the Color StyleWriter 4500 software.

Name in Font menu	Number of fonts	Font family (and styled fonts)	Comes with
Avant Garde	4	ITC Avant Garde® (plain, italic, bold, and bold-italic)	Color StyleWriter 4500
Bookman	4	ITC Bookman® (plain, italic, bold, and bold-italic)	Color StyleWriter 4500
<b>Chicago</b>	1	Chicago	Macintosh
Courier	4	Courier (plain, italic, bold, and bold-italic)	Macintosh
DELPHIAN	1	Delphian	Color StyleWriter 4500
Garamond Narrow	4	ITC Garamond® Narrow (plain, italic, bold, and bold-italic)	Color StyleWriter 4500
Geneva	1	Geneva	Macintosh
Helvetica	4	Helvetica® (plain, italic, bold, and bold-italic)	Macintosh
<b>Helvetica Black</b>	2	Helvetica Black (plain and italic)	Color StyleWriter 4500
<b>Helvetica Compressed</b>	2	Helvetica Compressed (plain and italic)	Color StyleWriter 4500

*continued* ►

Name in Font menu	Number of fonts	Font family (and styled fonts)	Comes with
Lubalin Graph	4	ITC Lubalin Graph® (plain, italic, bold, and bold-italic)	Color StyleWriter 4500
Lucida Bright	4	Lucida Bright (plain, italic, bold, and bold-italic)	Color StyleWriter 4500
<b>MACHINE</b>	1	ITC Machine®	Color StyleWriter 4500
Monaco	1	Monaco	Macintosh
N Helvetica Narrow	4	Helvetica Narrow (plain, italic, bold, and bold-italic)	Color StyleWriter 4500
<i>Nadianne</i>	2	Nadianne (plain and bold)	Color StyleWriter 4500
New Century Schoolbook	4	New Century Schoolbook (plain, italic, bold, and bold-italic)	Color StyleWriter 4500
New York	1	New York	Macintosh
Old English Text	1	Old English Text	Color StyleWriter 4500
Onyx	1	Onyx	Color StyleWriter 4500
Oxford	1	Oxford	Color StyleWriter 4500
Palatino	4	Palatino® (plain, italic, bold, and bold-italic)	Macintosh
<i>Swing</i>	1	Swing	Color StyleWriter 4500
Συμβολ (Symbol)	1	Symbol	Macintosh
Times	4	Times® (plain, italic, bold, and bold-italic)	Macintosh
<i>Zapf Chancery</i>	1	ITC Zapf Chancery® StyleWriter 4500	Color
☼☼☼☼ ☼☼☼☼ ☼☼☼☼ ☼☼☼☼ (Zapf Dingbats)	1	ITC Zapf Dingbats®	Color StyleWriter 4500
⌘ ⏏ ⏏ (Zeal)	1	Zeal	Color StyleWriter 4500
<b>Total</b>	<b>64</b>		



## Appendix D Using ColorSync

Mac OS–based computers use ColorSync to help make sure that the colors you see on your monitor closely match the colors you get on your printers, scanners, and other devices. Because ColorSync works behind the scenes, you don't have to know anything about it. All you need to do is initially set it up. This appendix describes how ColorSync works and how to configure your monitor and computer to take advantage of it.

### The problem that ColorSync solves

Providing consistent color with desktop computers is a technical challenge because different color devices use different methods for representing color, and they produce different ranges of colors. For example, the colored light on your monitor is very different from the colored inks your printer uses.

Different color devices also create color using different methods. Monitors (and most scanners) produce colors by mixing red, green, and blue light—called *RGB color*. Most printers produce colors by mixing cyan (a shade of blue), magenta (a bright pink), yellow, and black ink. This color system is called *CMYK*. Since monitors, printers, and scanners each have different color capabilities, they cannot reproduce each other's colors exactly.

Further compounding the problem is that no two monitors or printers produce exactly the same colors. (For example, you can see differences in color ability among monitors in the TV department of a consumer electronics store.)

ColorSync is a system extension that provides color-conversion capabilities and improves color consistency. ColorSync “translates” the colors used on one device so that they more closely match the colors displayed or printed on another device.

ColorSync color conversion is a central part of Mac OS–based computing, ensuring that applications, monitors, printers, scanners, and digital cameras can use the same scheme for color conversion. This means you can scan an image, display it on your monitor, and print it—with visually matching colors every step of the way.

## How ColorSync works

When you create a TIFF or PICT file using a program that supports ColorSync, a “profile” describing the color capabilities of your equipment is saved with the image. For example, when you scan a photograph, a profile describing the scanner is saved inside the image file. If you later print the image, even using a different computer, ColorSync looks at the profile to learn about the capabilities of the scanner you used, and automatically picks closely matching colors that your printer can reproduce.

The profile contains information ColorSync needs to perform color matching, such as the lightest and darkest possible tones (white point and black point) that the device can produce, and the maximum supported densities for red, green, blue, cyan, magenta, and yellow. Together, these characteristics describe the *color gamut* (or *range*) that a device is capable of capturing, displaying, or reproducing. To take advantage of ColorSync, each of the imaging devices you use needs to have its own ColorSync profile. When you create images using these devices, information from the profile will automatically become part of the image file—ensuring that colors are consistent throughout the entire creative process.

Because ColorSync information becomes part of your output files, you don't have to worry about losing the profile or using the wrong profile with the wrong image. Additionally, ColorSync profiles are in the standard International Color Consortium (ICC) format recognized by Microsoft Windows, Mac OS, and other systems.

When you work with an image that has an embedded ColorSync or ICC profile, ColorSync identifies the colors that your monitor or printer can reproduce by examining their ColorSync profile. It compares their capabilities with those of the system used to create the image (as described in the embedded profile), and then picks appropriate, matching colors. For example, your monitor may be able to display a vivid red, but your printer inks may not be able to produce that color. ColorSync determines the “next best” color for your printer to use.

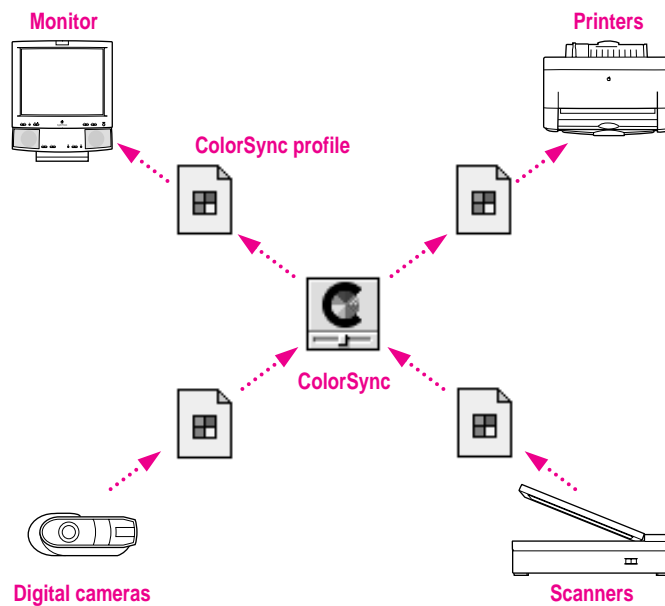

ColorSync performs color matching by comparing each profile to an independent color standard. ColorSync uses the CIE color standard, which describes colors in terms of how they are perceived by the human eye under specific lighting conditions. (CIE stands for the Commission International de l’Eclairage, the International Commission on Illumination, which created the standard in 1931.)

## Setting up ColorSync

To take advantage of ColorSync, you need to obtain profiles for each of your imaging devices, such as your monitor, scanner, and color printer. ColorSync profiles are usually automatically installed when you install the software for a ColorSync-supported device. Profiles are stored in the ColorSync Profiles folder, inside Preferences in the system folder. If you need to obtain a ColorSync profile, contact the manufacturer of your device. Ask for either a ColorSync or ICC profile for the specific model of monitor, printer, or scanner you're using.

You also need to make sure the ColorSync extension and Apple CMM 2 are installed and active. ColorSync is automatically installed in the Extensions folder of your system folder during software installation. Unless you've removed or disabled it, it's already installed.

Finally, you need to set a ColorSync System Profile for the Mac OS. The ColorSync System Profile is used by ColorSync to determine the color range of your monitor. ColorSync compares this information with the profiles of your other devices to make sure that colors are consistent with what you see on your monitor.

Additionally, the System Profile is used as a default profile if a document you are working on doesn't have any ColorSync information saved within it. This can occur if the document was created without ColorSync installed. By using the System Profile as a default, ColorSync ensures that colors are consistent with what you currently see on your monitor.

For the best color on your Color StyleWriter 4500 printer, you need to choose a specific profile for your monitor. In the ColorSync control panel, choose the D50 profile for your monitor. If there is no D50 available for your monitor, choose Apple Multiple Scan 17 – D50. The D50 profile gives you better “warm” colors.



For the best visual match between the colors on your monitor and printed colors, select the Page-White Gamma option in the Monitors control panel. (On some computers, this may be called the Monitors & Sound control panel.) To select a gamma option, open the Monitors control panel, then hold down the Option key while you click the Options button. In the Options window, click the Use Special Gamma checkbox to put a check in it. Then choose Page-White Gamma from the menu.

On a multiscan monitor, make sure that the color temperature, or intensity, is set to 9300 K (the default setting). See the monitor manual for instructions. If you select the Page-White Gamma option with a color temperature other than 9300 K, your monitor colors could look too red or too blue compared to printed colors.

## Setting the ColorSync System Profile

To set the System Profile, follow these steps:

- 1 **Make sure the profile you want to use is located in the ColorSync Profiles folder.**

This folder is located in the Preferences folder in your System Folder.

- 2 **Choose Control Panels from the Apple () menu and open the ColorSync System Profile control panel.**

The ColorSync System Profile control panel appears.

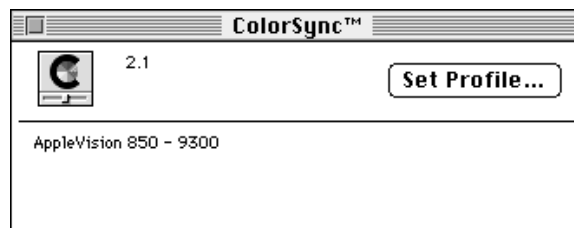

- 3 **Click Set Profile.**

A dialog box appears with a list of ColorSync profiles installed on your computer.

- 4 Click the profile you want to use.

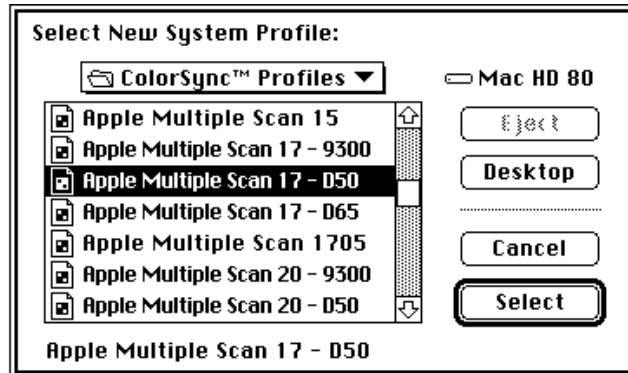

Select the D50 profile for your monitor, or Apple Multiple Scan 17 D50 if you can't find a D50 profile for your monitor.

- 5 Click Select.

ColorSync automatically references the profile you selected and uses it to define the color capabilities of your monitor.

- 6 Close the ColorSync System Profile control panel.

## Setting other ColorSync profiles

Some programs and printer software might require that you do something special, such as turning on an option, in order to take advantage of ColorSync. For example, to use ColorSync with the Apple Color OneScanner, select the Use ColorSync option in the ColorSync Preferences dialog box of the OneScanner Dispatcher software. This tells the scanning software to embed information about the Color OneScanner in scanned images.

Refer to the instructions that came with your application or device to determine if it supports similar options. If there's an option to specify a profile or to activate ColorSync, be sure to use it.

## Tips for best results

After you've made sure ColorSync is installed, set the System Profile, and set any necessary ColorSync options for your applications, you're ready to begin taking advantage of ColorSync! Just scan, create, and print your images or documents as you normally would. ColorSync works behind the scenes to ensure consistent color matching.

The following settings and strategies will help you get the best color results from your system. Not all of these tips will apply to the software and devices you may be using, but be sure to take advantage of those tips that do.

- Set the gamma curve for your monitor to 1.8:Standard to have the monitor more closely match printed results..
- Use the ColorSync System Profile control panel in the Apple () menu to select the D50 profile for your monitor, or Apple Multiple Scan 17–D50 if you can't find a D50 profile for your monitor. If you calibrate your monitor, you can create a custom profile and select it as the system profile instead. See the documentation that came with your monitor for more information on creating custom ColorSync profiles.
- When printing in color, check to see if the printing options include a setting for ColorSync. For example, for the Apple LaserWriter 12/600 PS, turn on ColorSync by clicking the Options button and selecting “ColorSync Color Matching.”
- If your scanning program has a ColorSync option, use it. This embeds a ColorSync profile within the scanned image file, and ColorSync will be better able to reproduce the original colors on your monitor and printer.
- Don't try to use two color-matching systems at once on your computer. Some applications install other color-matching systems. These should either be removed or disabled if you want to use ColorSync.

## For more information

To learn more about ColorSync, or color matching and color technology in general, refer to these publications and resources.

### Publications

*Advanced Color Imaging on the Mac OS*, Apple Computer, Inc., Addison-Wesley Developers Press, ISBN 0-201-48949-X

ColorSync 2.0 White Paper at <gopher://info.apple.com>

### Internet Resources

Apple Imaging Web Site at <http://imaging.apple.com>

Apple Technical Information Library at <http://til.info.apple.com>

International Color Consortium at <http://www.color.org>

ColorSync plug ins for use with Adobe Photoshop (Macintosh Utilities section of the Apple Software Updates page on the Apple Support and Information Web at <http://www.info.apple.com>)





**Can't Find It? See also Macintosh Guide's onscreen index. Open the Guide (Ⓜ) menu and choose Macintosh Guide; then click the Index button.**



## Index

• • • • •

### A

- A4 paper 13, 91
- AC power adapter 3, 92
- Adobe PostScript font icon 98
- Adobe Type Manager 79, 98, 100, 106
- alcohol-based or ammonia-based cleaners 2, 63
- alias for a desktop printer icon, creating 40
- Align Top Left watermark scaling option 35, 36
- Apple-authorized dealer/service provider
  - obtaining ink cartridges and supplies 58
  - purchasing new system software or memory 15
  - repair assistance 65
  - waste ink container is full 77
- Apple classic fonts 107
- Apple menu, Turn Desktop Printing Off 123
- Apple part numbers list 93–94
- Apple System/Peripheral-8 cable 3, 90, 93
- AppleTalk network, sharing the printer 44–46
- Application menu, PrintMonitor command 128
- audio alert of print completion 30

### B

- background printing
  - low memory and 78, 79
  - monitoring and controlling 42–43
  - PrintMonitor and 128
  - QuickDraw GX and 115
  - turning on or off 41
  - working with 28, 31
- back-print film
  - backwards printing and 81
  - loading into the sheet feeder 26, 51, 75
  - print quality setting for 120
  - tips for using 51
- Best print quality option 30, 52, 119, 120
- bitmapped font icon 97
- bitmapped fonts
  - Apple classic fonts 107
  - described 97
  - PostScript and 98
  - TrueType and 99–100, 106
- Bitstream PostScript font icon 98
- black ink cartridge
  - printing speed and 53
  - vs. color ink cartridge 4
  - when to replace 58
- borders around mini pages 29, 37



**Can't Find It?**

**See also Macintosh Guide's onscreen index.**  
**Open the Guide (⌘) menu and choose Macintosh Guide; then click the Index button.**

## C

### cables

- Apple System/Peripheral-8 3, 90, 93
- checking connections 70
- LocalTalk 11
- network 11
- serial 11

“carbonless carbon” paper 49, 82

### carrier

- handling of 7–8, 10
- replacing the ink cartridge and 59, 61

Centered watermark scaling option 35, 36

changing the order of items to print, background printing and 43

### Chooser

- changing the default printer 39
- selecting the printer 17, 28
- setting up the printer for network use 45–46
- setting up the printer for QuickDraw GX 115–117
- turning background printing on or off 41
- user instructions for a shared printer 47

Chooser dialog box 17, 115–117

CIE color standard 113

### cleaning

- the printer 2, 63, 87
- the print head 30, 84–85, 122

CMYK color system 111

coated paper 26, 50, 119

### color ink cartridge

- vs. black ink cartridge 4
- when to replace 58

color matching, turning on 32–33

color options, adjusting 30, 32–33

Color Options dialog box 32–33, 52

### color printing

- quirks 33
- troubleshooting 82, 84

ColorShare 42, 44, 85

*Color StyleWriter 2500 Disk I* 14, 68, 125

Color StyleWriter 2500 icon 16, 17, 31, 66

Color StyleWriter 2500 Log file 46

Color SW 2500-Troubleshooting file 19–20. *See also* test page

### ColorSync

- control panel 32, 113, 121
- described 111–113
- profiles 32, 112, 113, 121
- turning on 32–33, 52

columns, printing, troubleshooting 81

### connecting the printer

- to use on a LocalTalk or EtherTalk network 48
- to use on an AppleTalk network 44–46
- to use with QuickDraw GX 115–117
- to your Macintosh 11

Connect via pop-up menu (Chooser dialog box) 115–116

controlling print requests. *See* monitoring and controlling print requests

### control panels

- ColorSync System Profile 32, 113, 121
- Monitors 113

copies, selecting number to print 30

cost of printing, reducing 53

creating a desktop printer icon 40

Custom Install dialog box 69

Custom Install option 16, 68–69

Custom Remove dialog box 126

Custom Remove option 126–127

## D

- damaged paper 49, 74–75, 82
- default desktop printer icon 38, 40
- default printer, changing 38–39
- deleting a print request, background printing and 42
- density of watermarks 35, 36
- desktop printer
  - creating 17, 40, 116
  - formatting a document for, QuickDraw GX 118
- desktop printer icons
  - appearance after removing desktop printer software 127
  - creating, throwing away, or manipulating 40
  - examples of 16, 31
  - troubleshooting 71
- desktop printing 31
  - low memory and 78
  - turning off QuickDraw GX 123
- desktop printing software, removing 125–127
- Desktop PrintMonitor 79
- dialog boxes
  - Chooser 17, 115–117
  - Color Options 32–33, 52
  - Custom Install 69
  - Custom Remove 126
  - Installer 15, 68, 126
  - Page Setup 19, 29, 37, 80, 117
  - Page Setup, expanded QuickDraw GX version 118
  - Print 20, 30, 52, 85, 119
  - Print, expanded QuickDraw GX version 120–122
  - PrintMonitor 128
  - Setup 45
  - Utilities 85
  - Watermark Options 35
- dimensions of printer 91
- disabled (X) desktop printer icon 40, 71, 127

- disconnecting the printer. *See* unplugging the printer
- disks, locking 14
- display fonts 106
- distorted print output, troubleshooting 87
- document icon 31
- downloadable fonts 108
- Draft print quality option 30, 53, 119, 120

## E

- electromagnetic interference 4
- energy-saving feature 6
- engine specifications of the printer 89
- enlarging the printed image. *See* scaling
- envelope icon 24, 25
- envelopes
  - feed improperly 74–75
  - formatting the text for 26, 27
  - loading into the sheet feeder 24, 75
  - setting the paper selectors for 24, 25
  - types to use 26, 77, 90, 91
- environment specifications 92
- erasable typing paper 49, 82
- error light 6, 21, 72
- error messages 70, 77
- EtherTalk network, connecting the printer to 48
- extensions, turning off 14
- external paper selector lever 13, 24

## F

- features of the printer, overview ix
- File menu
  - Page Setup command 19, 23, 29, 34–37, 117–118
  - Print command 20, 27–28, 30–33, 38, 119–122
  - Quit command 20
  - Save command 33



**Can't Find It?**

**See also Macintosh**

**Guide's onscreen index.**

**Open the Guide (🔍)**

**menu and choose**

**Macintosh Guide; then**

**click the Index button.**

filling the sheet feeder. *See* loading the sheet feeder

fixed-size fonts 97

folders

- Fonts 67, 102, 106
- font suitcases 103–104
- Printing Prefs 37, 46, 81

Fontek PostScript font icon 98

font families 109–110

fonts

- Apple classic fonts 107
- bitmapped 97, 99–100, 106
- corrupted, resolving installation problems 66–69
- displaying in the Fonts menu 106
- downloadable 108
- Geneva appears as a substitute font 107
- how the Macintosh looks for 101
- installing 14
- list of 109–110
- low memory and 107
- making purchasing decisions 106
- naming 100
- organizing in suitcases 103–104
- PostScript 98, 100, 106
- QuickDraw GX 98
- search order 101
- storing on the computer 102–104
- styles for 105
- supported by the printer 90, 95, 109–110
- TrueType 96–97, 99–100, 106
- used for display 106
- viewing on-screen 96–97

Fonts folder 102, 106

- removing items from 67

Fonts menu 106

font styles 105

font substitution 107, 108

font suitcases 102–104

four-color ink cartridge. *See* color ink cartridge

future print time, setting 43

## G

Get Info command 78

glossy paper 26, 50, 82, 120

guide. *See* paper guide

## H

halftoning method, selecting 32, 38, 52, 121

hardware requirements x

high-performance black ink cartridge. *See* black ink cartridge

holding a print request, background printing and 43

horizontal orientation. *See* landscape orientation

horizontal white lines appear on the printed page, troubleshooting 84

humidity range for the printer 92

## I

icons

- bitmapped font 97
- Color StyleWriter 2500 16, 17, 31, 66
- Color SW 2500-Troubleshooting file 19
- default desktop printer 38, 40
- desktop printer 16, 31, 40, 71, 127
- disabled (X) desktop printer 40, 71, 127
- document 31
- envelope 24, 25
- modem port 11, 18
- paper 24, 25
- PostScript font manufacturers 98
- printer error 40
- printer port 11, 18
- printing 40
- stopped print queue 40

image print option

- low memory and 78
- selecting 30, 119, 121



- ink
    - checking if the printer is out of ink 76
    - reducing the amount used 53
    - smears when rubbed,
      - troubleshooting 83
  - ink cartridges
    - extending the life of 88
    - installing 7–10
    - part numbers for 93
    - preventing from drying out 4, 6, 62
    - replacing 58–61
    - storing 4, 62
    - switching 53
    - troubleshooting 76
    - unpacking 3
  - ink cartridge storage case 3, 4, 62
  - ink tanks
    - extending the life of 88
    - part numbers for 93
    - replacing 55–57
    - safety instructions for 66
    - troubleshooting 76
  - ink waste container 77
  - inserting paper into the sheet feeder. *See*
    - loading the sheet feeder
  - installation problems, troubleshooting 66–69
  - Installer dialog box 15, 68, 126
  - Installer program 14–16, 68–69, 125–127
  - installing
    - fonts 14
    - ink cartridges 7–10
    - printer software 14–16, 68–69
    - QuickDraw GX software 14
  - interface specifications of the printer 90
  - interference with television and radio reception vi
  - internal modem on PowerBook
    - computers 11, 17, 18, 70
  - internal paper selector lever 12, 25, 87
- J**
- jagged edges on printed output 96, 97
  - jammed or damaged paper, removing 73, 75
- K**
- Key Caps desk accessory 97
- L**
- labels 26
  - landscape orientation
    - low memory and 78
    - setting 29, 117, 118
  - layout, adjusting 29
  - Layout pop-up menu (Page Setup dialog box) 37
  - legal-size paper 13, 25
  - letterhead paper 24
  - letter-size paper 13, 27–28
  - lights on the printer 6, 21, 72
  - liquid cleaners 63
  - liquid spills in the printer 2
  - loading the sheet feeder
    - with back-print film or transparencies 26, 51, 75
    - basic instructions 12–13, 24–25
    - with envelopes 24, 26, 75
    - with labels 2, 26
    - with various kinds of paper 26, 49–50
  - LocalTalk cable 11
  - LocalTalk network, connecting the printer to 48
  - location for the printer, choosing 4
  - locking disks 14
  - log file for printer usage 46



### Can't Find It?

See also **Macintosh Guide's onscreen index**.  
Open the **Guide (?)** menu and choose **Macintosh Guide**; then click the **Index** button.

## M

maintenance tasks. *See also* safety instructions  
cleaning the printer 2, 63, 87  
replacing ink tanks 55–57  
replacing the ink cartridge 58–61  
storing a second ink cartridge 62  
Matching Method pop-up menu (Color Options dialog box) 33  
memory  
low memory indications and suggestions 78–79  
required for the printer x  
virtual memory 4, 79  
messages on-screen 70, 77  
mini pages (2 or 4), printing 29, 37  
modem port 11, 17, 18  
moisture exposure to the printer 2  
monitoring and controlling print requests  
with background printing on 42–43  
on a network printer 47  
without desktop printers 128  
Monitors control panel 113  
moving a desktop printer icon 40  
moving a print request to another printer, background printing and 43  
moving the printer a long distance 129–130  
multipart forms 49, 82

## N

naming  
fonts 100  
font suitcases 104  
network cable 11  
networks  
AppleTalk 44–46  
LocalTalk or EtherTalk 48  
network zones 47, 116  
non-standard documents, printing 28–31

Normal print quality option 30, 53, 119, 120  
notification of print completion, selecting 30  
nozzle test pattern, interpreting 22, 86  
number of copies to print, selecting 30

## O

opening the printer 7, 25, 56, 59, 87  
operating environment specifications 92  
orientation  
low memory and 78  
setting 29, 117, 118  
output tray, opening 13, 25

## P

packing the printer 129–130  
page breaks, change unexpectedly, troubleshooting 80  
Page Setup command (File menu) 19, 23, 29, 34–37, 117–118  
Page Setup dialog box 19, 29, 37, 80, 117  
expanded QuickDraw GX version 118  
page setup options. *See also* print options setting 23, 29, 34–35, 37, 117–118  
page size, adjusting 29, 117  
pages to print, selecting 30  
paper. *See also* print materials  
jammed or feeding improperly 73–75  
loading into the sheet feeder 12–13, 24–25, 75  
saving 37  
sizes supported 91  
types not to use 49, 82  
types to use 26, 49–50, 77, 82, 90  
paper guide, adjusting 13, 24, 75  
paper icon 24, 25  
paper-matching feature, QuickDraw GX 120

- paper selector lever
  - external 13, 24
  - internal 25, 87
- paper support, extending 13, 24
- paper type, indicating 30, 77, 118, 119, 121
- part numbers list 93–94
- password for network printer usage 45, 47
- Pattern halftoning option 32, 38, 83
- PICT/PICT2 format files, watermarks and 36, 81
- pictures do not print, troubleshooting 80
- pixels 96
- plain paper
  - tips for using 49
  - troubleshooting 82, 83
  - weight recommended 26, 49, 90
- platen, cleaning 63, 87
- plugging in the printer 5
- portrait orientation
  - low memory and 78
  - printing in 27
  - setting 29, 117, 118
- ports
  - changing the selection 70
  - modem and printer 11, 17, 18
  - serial, PowerBook computers 18
- PostScript fonts
  - described 98
  - downloadable 108
  - TrueType and 100, 106
- PostScript page description language 79, 80, 98
- power adapter 3, 92
- PowerBook computers
  - internal modems and 11, 17, 18, 70
  - selecting the correct system profile for ColorSync 32, 121
- power button 6, 21, 72
- power consumption specifications 92
- power light 6, 21, 72
- Power Macintosh computers, virtual memory and 4
- power requirements for AC power adapter 92
- power-saving feature 6
- power strip, turning off 6
- precautions. *See* maintenance tasks; safety instructions
- premium coated/premium plus coated paper 26, 50, 90
- printable area 91
- Print command (File menu) 20, 27–28, 30–33, 38, 119–122
- Print dialog box 20, 30, 52, 85, 119
  - expanded QuickDraw GX version 120–122
- printer error icon 40
- printer log file 46
- printer port 11, 17, 18
- Printer Profile pop-up menu (Color Options dialog box) 33
- printer software
  - installing 14–16, 68–69
  - removing 125–127
- print head
  - cleaning 30, 84–85, 122
  - handling of 8–9, 59
  - preventing from drying out 4, 6, 62
  - troubleshooting 83, 84, 86
- printing. *See also* background printing; desktop printing; troubleshooting
  - adjusting color options 30, 32–33
  - back-print film 26, 51, 75, 81, 120
  - borders around mini pages 29, 37
  - color printing quirks 33
  - the Color SW 2500-Troubleshooting file 19–20
  - envelopes 24, 25, 26, 27, 74–75
  - labels 26
  - in landscape orientation 29, 117
  - legal-size paper 13, 25
  - letterhead paper 24



**Can't Find It?**

See also **Macintosh Guide's onscreen index**.  
Open the **Guide (?)** menu and choose **Macintosh Guide**; then click the **Index** button.

- mini pages (2 or 4) 29, 37
  - non-standard documents 28–31
  - on a shared printer 47
  - on various paper finishes 26
  - in portrait orientation 27–28, 29, 117
  - previously formatted documents 31
  - with QuickDraw GX 115–122
  - reducing cost of 53
  - scaled documents 29, 34, 117, 118
  - selected pages of a document 30
  - several documents at once 31
  - specific number of copies 30
  - standard documents 27–28
  - a test page 19–20, 56, 59, 84, 86
  - three-hole punched paper 24
  - transparencies 26, 51, 75, 120
  - troubleshooting 69–88
  - U.S. letter-size paper 27–28
  - utilities for 30
  - watermark images 29, 34–37
  - while using your computer 41–43
  - without leaving the Finder 31
  - printing icon 40
  - Printing menu, Set Default Printer command 39
  - Printing Prefs folder 37, 46, 81
  - print materials. *See also* back-print film; envelopes; paper; transparencies
    - part numbers for 93
    - standard and non-standard, printing 27–31
    - tips for choosing 49–51
    - types to use 24, 26, 90–91
  - PrintMonitor command (Application menu) 128
  - PrintMonitor dialog box 128
  - PrintMonitor program
    - changes to printing software and x using if you don't have desktop printers 128
  - print nozzles, checking 21–22
  - print options. *See also* page setup options
    - setting 30, 32–33, 39, 119–122
  - print quality
    - for greater speed 53
    - QuickDraw GX printing and 119, 120, 121
    - selecting 30, 52
    - troubleshooting 82–87
  - print queue
    - removing requests from 79
    - working with 42–43
  - print requests
    - deleting multiple requests for a document 70
    - monitoring and controlling 42–43, 47, 128
    - removing 79, 128
    - scheduling 120, 128
  - print time, setting, background printing and 43
  - profiles, ColorSync 32, 112, 113, 121
  - proportional space numerals 106
- Q**
- quality options. *See* print quality
  - QuickDraw GX
    - background printing and 41
    - cleaning the print head 122
    - expanded Page Setup dialog box 118
    - expanded Print dialog box 120–122
    - font features 98
    - installing 14
    - network printing and 44, 70
    - page setup definition 117–118
    - printing with 119–122
    - setting up the printer for use with 115–117
    - turning off 123
    - typographic features of 106
  - Quit command (File menu) 20

## R

- radio and television reception,
  - interference with vi
- RAM. *See* memory
- Read Me file 32
- reducing the printed image. *See* scaling
- removing
  - desktop printing software 125–127
  - jammed or damaged paper 73, 75
- renaming
  - a desktop printer icon 40
  - a network printer 48
- repacking the printer 129–130
- replacing
  - the ink cartridge 58–61
  - ink tanks 55–57
- resetting the printer 71
- resolution
  - of bitmapped fonts 7
  - specifications of the printer 89
- Restart command (Special menu) 14
- restarting the computer with extensions
  - turned off 14
- RGB color system 111
- rollers, cleaning 63, 87
- rotated text, troubleshooting 79

## S

- safety instructions 1–2, 6, 66. *See also*
  - maintenance tasks
- Save command (File menu) 33
- saving
  - energy 6
  - paper 37
- scalable fonts 96, 97, 100
- scaling
  - adjusting 29, 34, 117, 118
  - of watermarks 35, 36
- Scatter halftoning option 32, 38, 52
- screen fonts 97
- serial cable 11

- serial port on PowerBook computers 18
- Set Default Printer command (Printing menu) 39
- Setup dialog box 45
- shared printers
  - cleaning the print head and 85
  - print requests to 42
  - setting up 44–48
  - troubleshooting 70, 79
  - user instructions for 47
- sheet feeder
  - capacity of 12, 26, 74, 90
  - loading 12–13, 24–26, 49–51
  - troubleshooting 73–75
  - unpacking 3
- size of printer 91
- software disks, unpacking 3
- software requirements x
- sorting items waiting to print,
  - background printing and 43
- Special menu, Restart command 14
- speed of printing, increasing 53
- stains on printed pages,
  - troubleshooting 87
- standard documents, printing 27–28
- stapled paper 49
- stopped print queue icon 40
- stopping items temporarily from printing,
  - background printing and 43
- storage case for ink cartridge 3, 4, 62
- storage environment specifications 92
- Stretch to Fit watermark scaling option 35, 36
- stripes appear on the printed page,
  - troubleshooting 84
- styles for fonts 105
- suitcases for fonts 102–104
- swash characters 106
- switching between printers 38–39
- system profile, ColorSync and 32, 112, 113, 121
- system requirements x



**Can't Find It?**

See also **Macintosh Guide's onscreen index**.  
**Open the Guide** (?)  
**menu and choose**  
**Macintosh Guide; then**  
**click the Index button.**

## T

- technical specifications of the printer 89–91
- television and radio reception, interference with vi
- temperature range for the printer 92
- test page, printing 19–20, 56, 59, 84, 86
- test pattern for print nozzles, interpreting 22, 86
- three-hole punched paper 24
- throwing away a desktop printer icon 40
- transparencies
  - loading into the sheet feeder 26, 51, 75
  - print quality setting for 120
  - tips for using 51
- troubleshooting
  - cable connections 70
  - color printing quirks 33
  - colors don't look right 84
  - colors skip or streak at the bottom of the page 82
  - Color SW 2500 icon doesn't appear in the Chooser 66
  - columns are misaligned when printed 81
  - computer crashes while attempting to print 69
  - corrupted fonts 66–69
  - deleting multiple print requests 70
  - error light indicates a problem 72
  - horizontal white lines appear on the printed page 84
  - ink cartridges and tanks run out of ink too quickly 76, 88
  - ink smears when rubbed 83
  - installation is unsuccessful 66–69
  - jagged text 79
  - lines fade or break up 83
  - low memory indications and suggestions 78–79
  - message states that no Color StyleWriter 2500 is connected 70–71
  - nothing prints 70–71, 76
  - nozzles in print head 83, 84, 86
  - page breaks change unexpectedly 80
  - paper is jammed or feeds improperly 73–75
  - a particular document won't print 76
  - pictures do not print 80
  - port selection 70
  - PowerBook computers 70, 71
  - power light indicates a problem 72
  - printer seems slow 73
  - printer software installation 16, 70
  - printing appears on only part of the paper 84
  - printing is backwards 81
  - printing is off center 80
  - printing is smeared, blurred, or smudged 83
  - printing is too light or too dark 83
  - print quality 82–87
  - resetting the printer 71
  - rotated text prints jagged 79
  - shared printers 70, 79
  - stains on printed pages 87
  - stripes appear on the printed page 84
  - text prints in Geneva font 79
  - watermark problems 81
  - wavy or distorted print output 87
- TrueType fonts
  - bitmapped fonts and 99–100, 106
  - described 96–97
  - downloadable 108
  - PostScript fonts and 100, 106
- Turn Desktop Printing Off (Apple menu) 123
- turning the printer on and off 6

## U

- unpacking the printer 3–4
- unplugging the printer 2, 5, 6, 63, 66
- urgent print requests, background printing and 43
- U.S. letter-size paper 13, 27–28
- Utilities dialog box 85
- utilities options to clean the print head 30, 85, 122

## V

- vertical orientation. *See* portrait orientation
- virtual memory
  - low memory condition and 79
  - Power Macintosh users and 4
- visual alert of print completion 30

## W, X, Y

- warranty on the printer 55, 65
- waste ink container 77
- Watermark Options dialog box 35
- watermarks
  - creating your own 36–37
  - low memory and 78
  - scaling 35, 36
  - specifying 29, 34–35
  - troubleshooting 81
- wavy print output, troubleshooting 87
- weight of printer 91
- weight recommended for paper 26, 49, 82, 90
- white lines appear on the printed page, troubleshooting 84
- wrinkled paper 49

## Z

- zones, network 47, 116



# Color StyleWriter 4500

*Color ink-jet printer for Mac OS users*



 Apple Computer, Inc.

© 1997 Apple Computer, Inc. All rights reserved.

Under the copyright laws, this manual may not be copied, in whole or in part, without the written consent of Apple. Your rights to the software are governed by the accompanying software license agreement.

The Apple logo is a trademark of Apple Computer, Inc., registered in the U.S. and other countries. Use of the “keyboard” Apple logo (Option-Shift-K) for commercial purposes without the prior written consent of Apple may constitute trademark infringement and unfair competition in violation of federal and state laws.

Every effort has been made to ensure that the information in this manual is accurate. Apple is not responsible for printing or clerical errors.

Apple Computer, Inc.  
1 Infinite Loop  
Cupertino, CA 95014-2084  
408-996-1010  
<http://www.apple.com>  
<http://imaging.apple.com>

Apple, the Apple logo, AppleShare, AppleTalk, AppleVision, Chicago, ColorSync, LaserWriter, LocalTalk, Mac, Macintosh, Macintosh Quadra, New York, PowerBook, Power Macintosh, StyleWriter, and TrueType are trademarks of Apple Computer, Inc., registered in the U.S. and other countries.

Extensions Manager, Finder, Geneva, Monaco, OneScanner, and QuickDraw are trademarks of Apple Computer, Inc.

Adobe, Acrobat, Adobe Illustrator, Adobe Type Manager, Photoshop, and PostScript are trademarks of Adobe Systems Incorporated or its subsidiaries and may be registered in certain jurisdictions.

Classic is a registered trademark licensed to Apple Computer, Inc.

Helvetica, Palatino, and Times are registered trademarks of Linotype-Hell AG and/or its subsidiaries.

ITC Avant Garde, ITC Bookman, ITC Garamond, ITC Lubalin Graph, ITC Machine, ITC Zapf Chancery, and ITC Zapf Dingbats are registered trademarks of International Typeface Corporation.

Other products and company names mentioned herein may be trademarks of their respective companies. Mention of third-party products is for informational purposes only and constitutes neither an endorsement nor a recommendation. Apple assumes no responsibility with regard to the performance or use of these products.

Simultaneously published in the United States and Canada.



# Contents



Communications regulation information vi

**Welcome ix**

**1 Setting Up Your Printer 1**

Important safety instructions 1

Unpacking the printer 3

Plugging in the printer 5

Connecting the printer directly to your computer 6

Connecting to a LocalTalk network (optional) 7

Turning the printer on and off 8

Power Macintosh users and virtual memory 8

Installing the ink cartridges 9

Installing your printer software 12

Telling your computer to use a directly connected  
Color StyleWriter 4500 16

Telling your computer to use a Color StyleWriter  
on a LocalTalk network 17

Loading paper into the paper tray 19

Aligning the ink cartridges 21

Printing the sample page 23

Using onscreen help 24

<b>2 Printing</b>	<b>27</b>
Planning documents with the Color StyleWriter 4500 in mind	27
Printing a document	28
Printing while you use your computer	31
Monitoring and controlling background printing	32
Adjusting color options	33
Printing a photograph	34
Printing a banner	38
Printing envelopes	42
Printing transparencies	47
Printing labels	49
Printing index cards and postcards	51
Manual duplex printing (two-sided)	54
Printing a flipped document	56
Defining your own custom paper sizes	57
Switching between printers	58
<b>3 Tips on Paper, Quality, Speed, and Cost</b>	<b>61</b>
Choosing print materials	61
Quality	65
Speed	66
Cost	66
<b>4 Maintaining Your Printer</b>	<b>67</b>
Replacing ink cartridges	68
Cleaning the outside of the printer	68

<b>5</b>	<b>Troubleshooting</b>	<b>69</b>
	Safety precautions	70
	The Chooser doesn't show the Color SW 4500 icon	70
	Installation is unsuccessful	70
	The computer crashes while attempting to print	72
	The computer doesn't recognize the Color StyleWriter 4500	72
	A PowerBook has trouble printing to the Color StyleWriter 4500	73
	The lights indicate a problem	74
	The printer seems slow	75
	Paper is jammed	76
	Paper or envelopes feed improperly	76
	The Color StyleWriter 4500 won't print a particular document	77
	The printer acts as if it's working, but nothing is printed on the page	77
	Messages appear on your computer screen	78
	Memory is low	78
	Documents did not print as expected	79
	Print quality is poor	81
	Ink cartridges run out of ink too quickly	85
<b>Appendix A</b>	<b>Technical Information</b>	<b>87</b>
<b>Appendix B</b>	<b>Using Fonts With the Color StyleWriter 4500</b>	<b>93</b>
<b>Appendix C</b>	<b>Font List</b>	<b>107</b>
<b>Appendix D</b>	<b>Using ColorSync</b>	<b>109</b>
	<b>Index</b>	<b>117</b>

## Communications regulation information

### FCC statement

This equipment has been tested and found to comply with the limits for a Class B digital device in accordance with the specifications in Part 15 of FCC rules. See instructions if interference to radio or television reception is suspected.

### Radio and television interference

The equipment described in this manual generates, uses, and can radiate radio-frequency energy. If it is not installed and used properly—that is, in strict accordance with Apple’s instructions—it may cause interference with radio and television reception.

This equipment has been tested and found to comply with the limits for a Class B digital device in accordance with the specifications in Part 15 of FCC rules. These specifications are designed to provide reasonable protection against such interference in a residential installation. However, there is no guarantee that interference will not occur in a particular installation.

You can determine whether your computer system is causing interference by turning it off. If the interference stops, it was probably caused by the computer or one of the peripheral devices.

If your computer system does cause interference to radio or television reception, try to correct the interference by using one or more of the following measures:

- Turn the television or radio antenna until the interference stops.
- Move the computer to one side or the other of the television or radio.
- Move the computer farther away from the television or radio.
- Plug the computer into an outlet that is on a different circuit from the television or radio. (That is, make certain the computer and the television or radio are on circuits controlled by different circuit breakers or fuses.)

If necessary, consult an Apple-authorized service provider or Apple. See the service and support information that came with your Apple product. Or, consult an experienced radio/television technician for additional suggestions.

**IMPORTANT** Changes or modifications to this product not authorized by Apple Computer, Inc., could void the FCC Certification and negate your authority to operate the product.

Use of a shielded cable is required to comply within Class B limits of Part 15 of FCC Rules.

**Industry Canada statement**

This Class B device meets all requirements of the Canadian Interference-Causing equipment regulations.

Cet appareil numérique de la Class B respecte toutes les exigences du Règlement sur le matériel brouilleur du Canada.

**VCCI Class 2 statement****情報処理装置等電波障害自主規制について**

この装置は、情報処理装置等電波障害自主規制協議会 (VCCI) の基準に基づく第二種情報技術装置です。この装置は、家庭環境で使用することを目的としていますが、この装置がラジオやテレビジョン受信機に近接して使用されると、受信障害を引き起こすことがあります。

取扱説明書に従って正しい取り扱いをしてください。





## Welcome

Congratulations on your purchase of the Apple Color StyleWriter 4500 printer. This book describes how to set up the printer and how to use it.

### Main features of the Color StyleWriter 4500

The Color StyleWriter 4500 works with most Mac OS–based computers.

- The Color StyleWriter 4500 prints high-quality color graphics and text on a variety of materials, including plain paper.
- Along with the printer, you have everything you need to print amazingly photorealistic images—right from your desktop. This is ideal for printing scanned images, images from photo CDs, and graphics from the Internet.
- The automatic sheet feeder holds up to 100 sheets of paper, up to 20 envelopes, and 20 sheets of continuous banner paper.
- You can connect the printer to a LocalTalk network or connect it directly to your computer with a serial cable.
- 35 available TrueType (outline) fonts print smoothly in a variety of sizes.



## System requirements

To install the printer software and use the Color StyleWriter 4500 printer with your Mac OS–based computer, you need

- a Mac OS–based computer with a 68030/33 MHz or higher central processing unit (CPU), any Macintosh model except a Macintosh Plus, II, SE, IIsi, IIfx, Classic®, Portable, or PowerBook 100
- Macintosh Operating System (Mac OS) version 7.1 or a later version
- at least 4 megabytes (MB) of random-access memory (RAM) for a non-Power Macintosh; if you have a Power Macintosh, 8 MB of RAM is the minimum requirement, and 16 MB is recommended
- at least 8 MB of space available on your hard disk for the printer software

The Installer program that comes with the Color StyleWriter 4500 automatically checks whether your computer meets these requirements. Chapter 1 explains how to use the Installer program.

